

# RAM PROMASTER



## UPFIT GUIDE



**THE PERFECT FIT  
FOR YOUR  
TOUGHEST JOBS**

# **HELPING MOBILE TECHNICIANS WORK MORE EFFECTIVELY BY PROVIDING ORGANIZED STORAGE SOLUTIONS**

**AT RANGER DESIGN,  
WE BELIEVE MORE IS POSSIBLE.**

We believe work vehicles and the technicians that drive them can become more organized, more efficient, more productive and more profitable. At Ranger Design we're committed to bringing you the products and services that make that possible.

More means helping you choose the right work van for your application, as well as giving you engineering support and expert advice to help design the most efficient work space in your new vehicle.

More also means getting that new van outfitted and on the road faster, so you can start using it for the reason you bought it.

We're committed to bringing you more, because we believe more is possible.



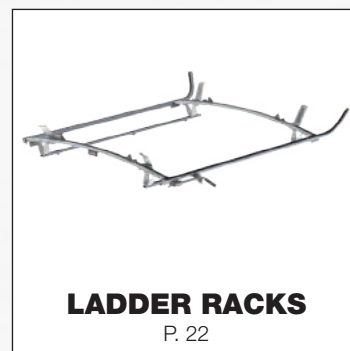
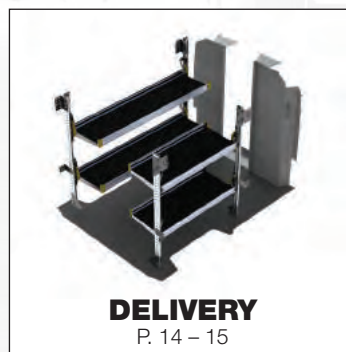
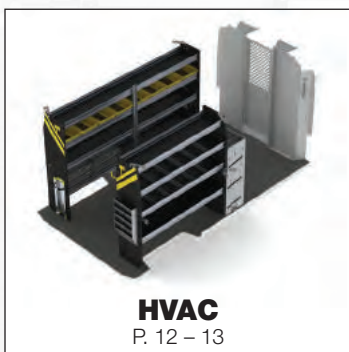
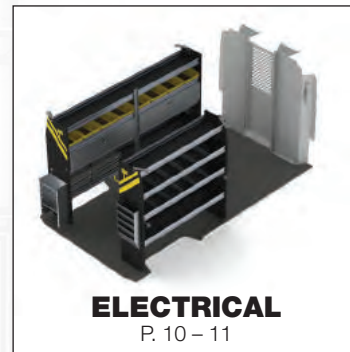

## Large Distributor Network Across the Continent

---

**Buy** Ranger Design Quickship service is available through your local distributor. [rangerdesign.com/find-distributor](http://rangerdesign.com/find-distributor)

---

**Lead Time** Quickship orders placed with Ranger Design before 1PM EST, will ship from our factory in the next business day.

---



All products shown in this upfit guide are available on Quickship

# HOW TO USE THE LAYOUT GUIDE

## INSIDE ROOF HEIGHT

To determine the maximum shelf height that can be used in the van.

## PARTITION DEPTH

This indicates the space taken up by our partition for this vehicle. Please note that this measurement is determined by the partition that encroaches the most. Some partitions may take up less space. Take note that this measurement may not necessarily be on the floor.

## DOOR OPENING

To determine where shelving will land in relation to the door opening. Use this measurement to determine the space available for drawer units.

## DIMENSIONS IN RED

These dimensions indicate unique measurements for each wheelbase. Use red dimensions to determine the exact wheelbase of your van.

## FLOOR SPACE

This area is usable floor space but due to curvature of the van there may not be the same available area at the roof. Please measure actual van for specific measurement at roof.

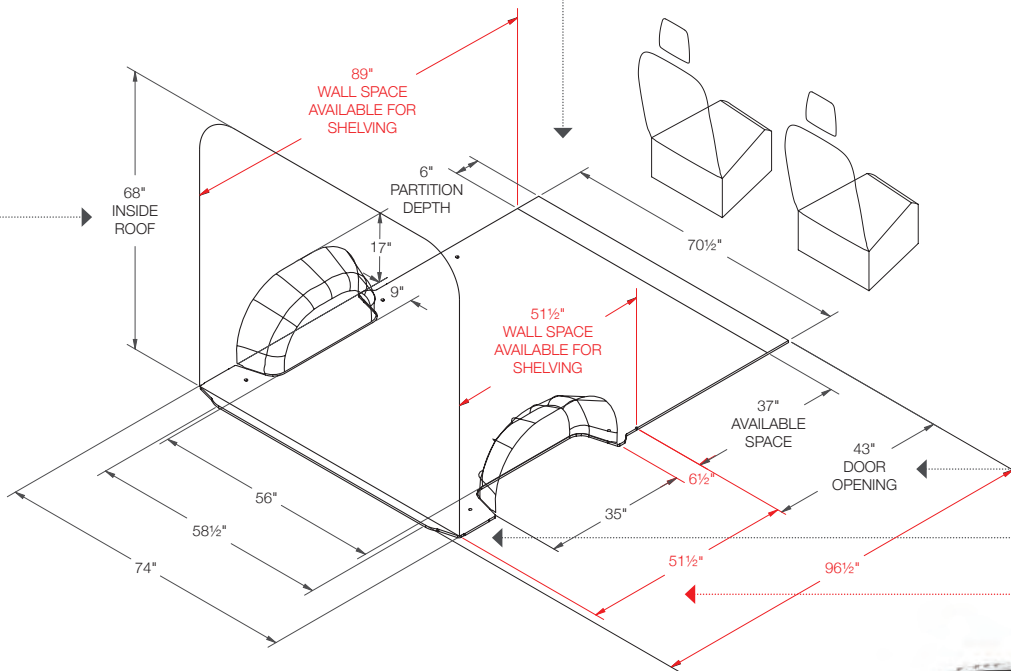

## RAM PROMASTER

Short 118" Wheelbase



## RAM PROMASTER

Medium 136" Wheelbase

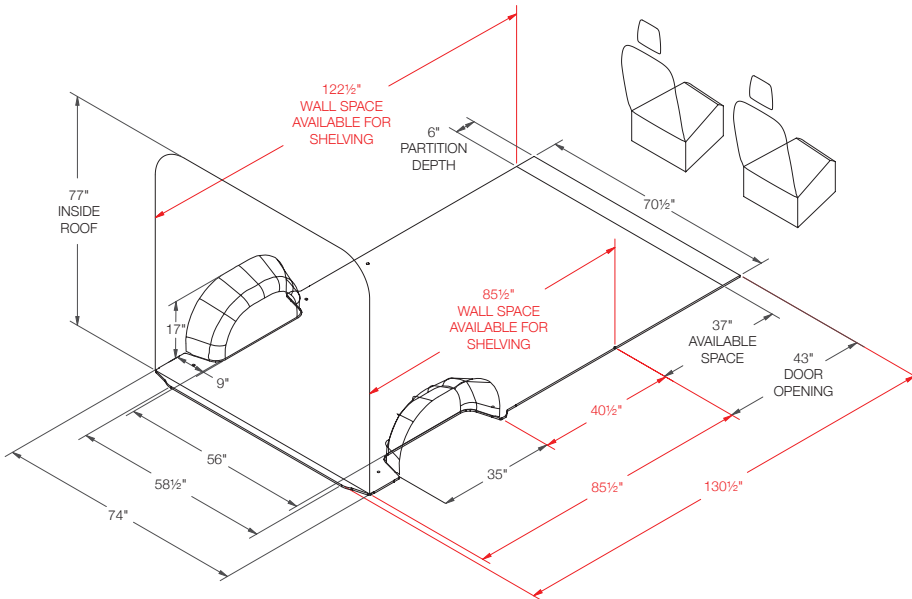
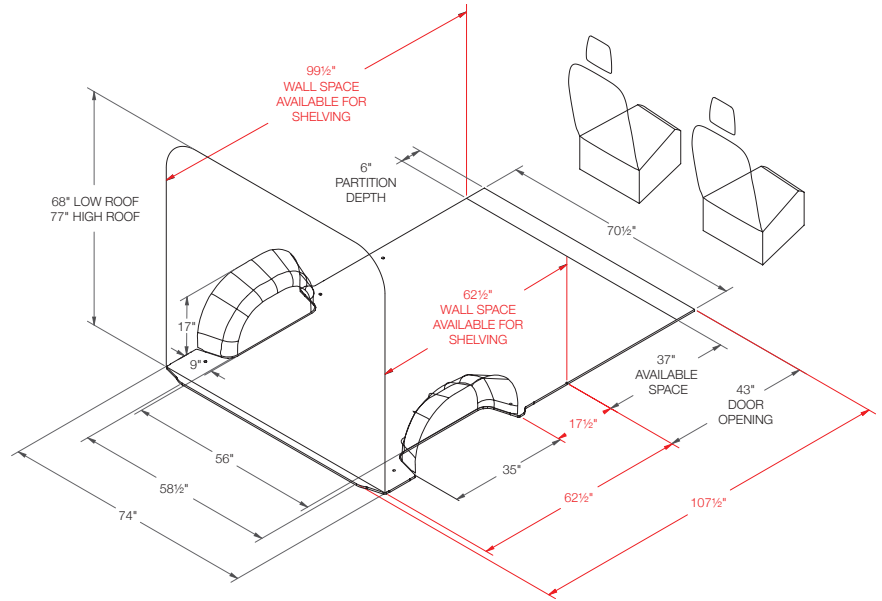

## RAM PROMASTER

Long 159" Wheelbase



## RAM PROMASTER

159" Extended Wheelbase

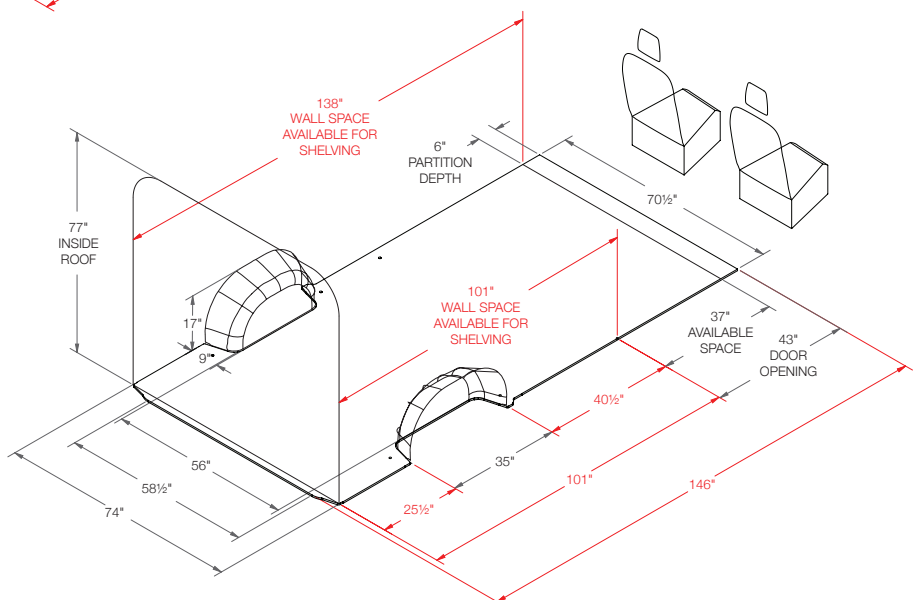

# CONTRACTOR

CONTRACTOR

## RPS-10

118" OR 136" WHEELBASE

> Low or High Roof



Qty	Part #	Description
1	6070	6" Hook, 3" opening, painted
1	C20-X	Straight steel partition with perforated window, no access
1	N5-RS48-4	Steel shelving unit for high roof van, 14" D x 48" W x 62" H
1	N5-RS72-4	Steel shelving unit for high roof van, 14" D x 72" W x 62" H

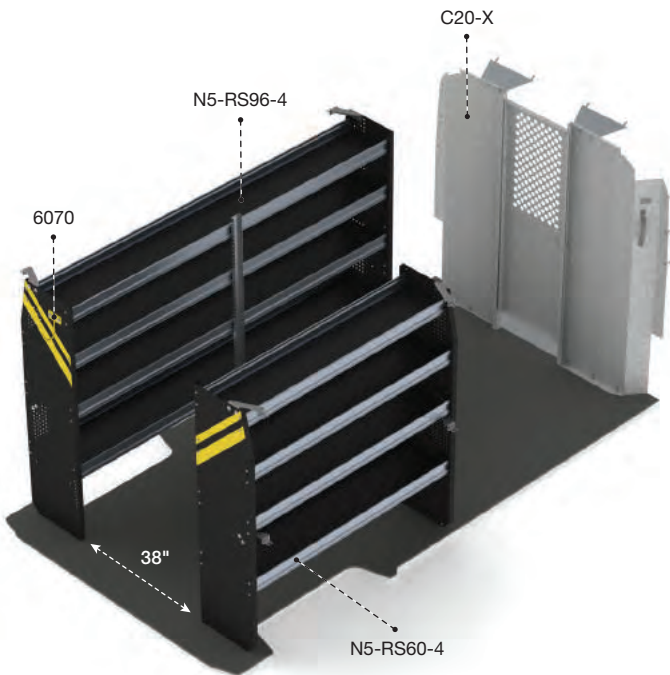
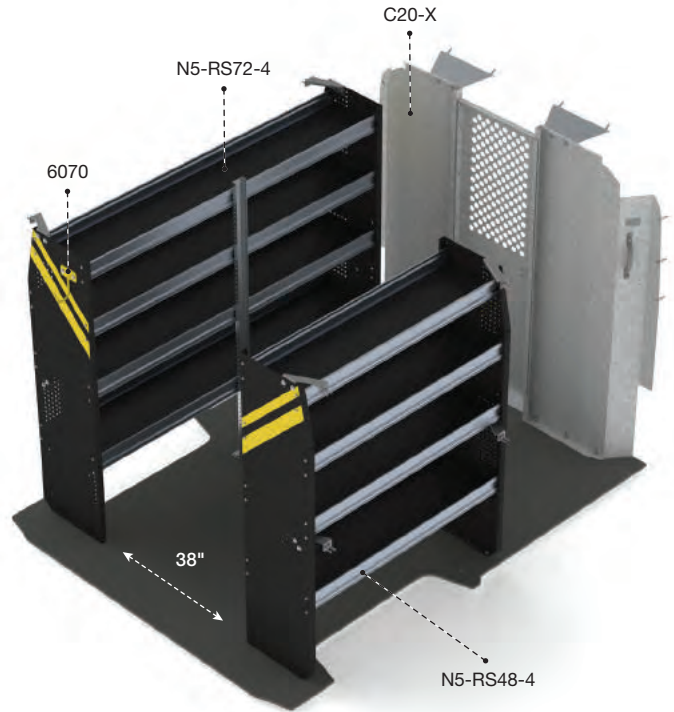

## RPL-10

159" OR 159" EXTENDED WHEELBASE

> High Roof

Qty	Part #	Description
1	6070	6" Hook, 3" opening, painted
1	C20-X	Straight steel partition with perforated window, no access
1	N5-RS60-4	Steel shelving unit for high roof van, 14" D x 60" W x 62" H
1	N5-RS96-4	Steel shelving unit for high roof van, 14" D x 96" W x 62" H





VISIT OUR WEBSITE FOR  
OUR FULL-LINE OF PARTITIONS

## RPS-10



### 6070

6" Hook,  
3" opening,  
painted



## RPS-16

118" OR 136" WHEELBASE

> Low or High Roof



Qty	Part #	Description
1	6070	6" Hook, 3" opening, painted
1	6072	8" Swivel hook, 4" opening, painted
4	62-U1114	14" Deep plastic bin
2	62-UDR14	Set of 5 dividers for a 14" shelf
1	C20-X	Straight steel partition with perforated window, no access
1	N5-RS48-4	Steel shelving unit for high roof van, 14" D x 48" W x 62" H
1	N5-RS72-4	Steel shelving unit for high roof van, 14" D x 72" W x 62" H
2	X50-B	Compact 2-drawer unit

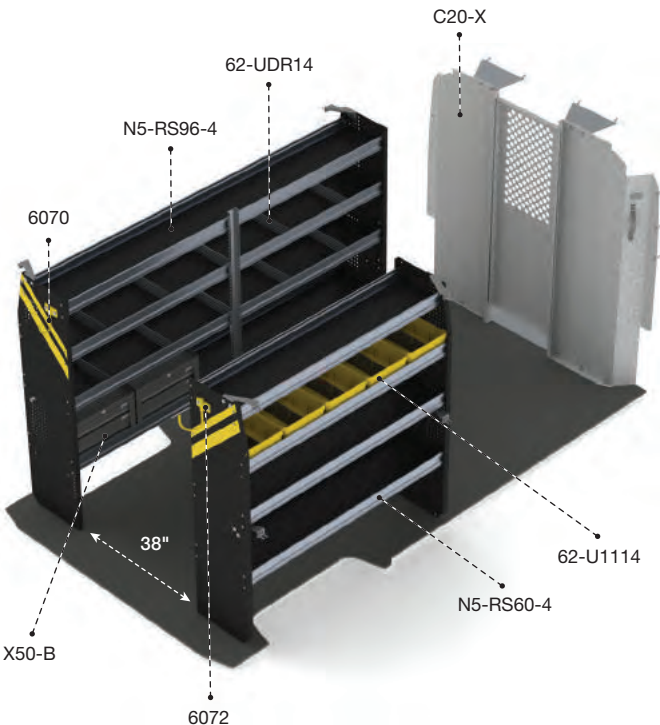
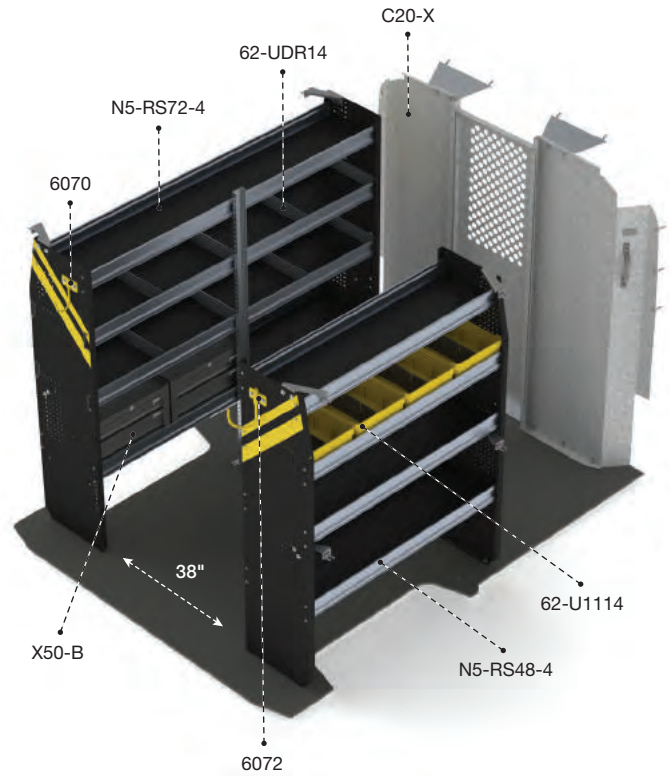

## RPL-16

159" OR 159" EXTENDED WHEELBASE

> High Roof

Qty	Part #	Description
1	6070	6" Hook, 3" opening, painted
1	6072	8" Swivel hook, 4" opening, painted
5	62-U1114	14" Deep plastic bin
2	62-UDR14	Set of 5 dividers for a 14" shelf
1	C20-X	Straight steel partition with perforated window, no access
1	N5-RS60-4	Steel shelving unit for high roof van, 14" D x 60" W x 62" H
1	N5-RS96-4	Steel shelving unit for high roof van, 14" D x 96" W x 62" H
2	X50-B	Compact 2-drawer unit







VISIT OUR WEBSITE FOR  
OUR FULL-LINE OF PARTITIONS

## RPS-16



**6072**

8" Swivel hook,  
4" opening, painted



**X50-B**

2 Drawer cabinet



**62-U1114**

14" Deep plastic bin  
with a center divider

**FOR MORE ACCESSORIES, SEE PAGE 20.**

## RPS-11

118" OR 136" WHEELBASE

> Low or High Roof



Qty	Part #	Description
1	6063	Paper holder, extra deep, 5 slots
1	6070	6" Hook, 3" opening, painted
1	6072	8" Swivel hook, 4" opening, painted
6	62-U1114	14" Deep plastic bin
2	62-UDR14	Set of 5 dividers for a 14" shelf
1	7124	Reel holder with two 5/8" diameter rods
2	77-U1036	Adjustable shelving door unit - 33" W - for 36" & 72"shelves
1	C20-X	Straight steel partition with perforated window, no access
1	N5-RS48-4	Steel shelving unit for high roof van, 14" D x 48" W x 62" H
1	N5-RS72-4	Steel shelving unit for high roof van, 14" D x 72" W x 62" H
1	X50-B	Compact 2-drawer unit
1	X50-C	Compact 3-drawer unit

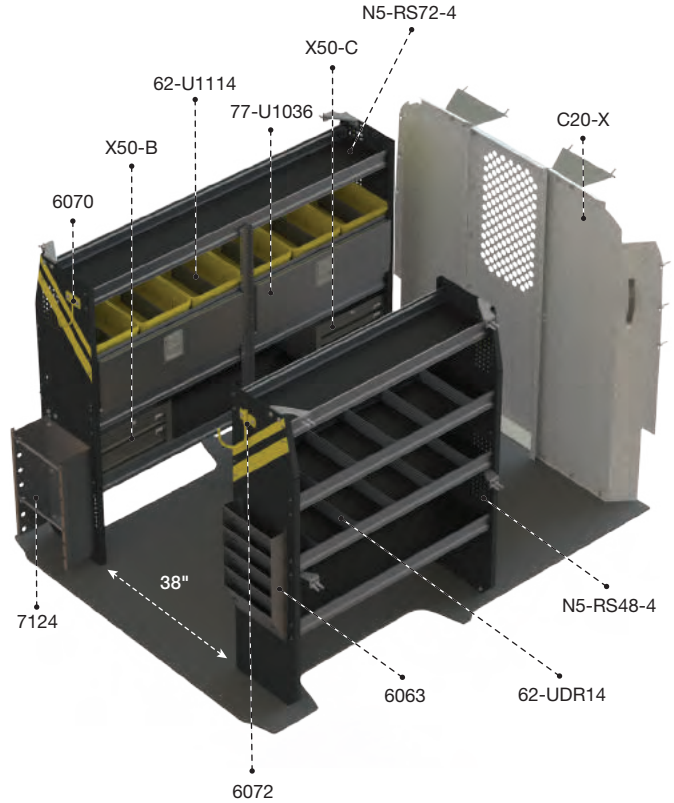

ELECTRICAL

## RPL-11

159" OR 159" EXTENDED WHEELBASE

> High Roof

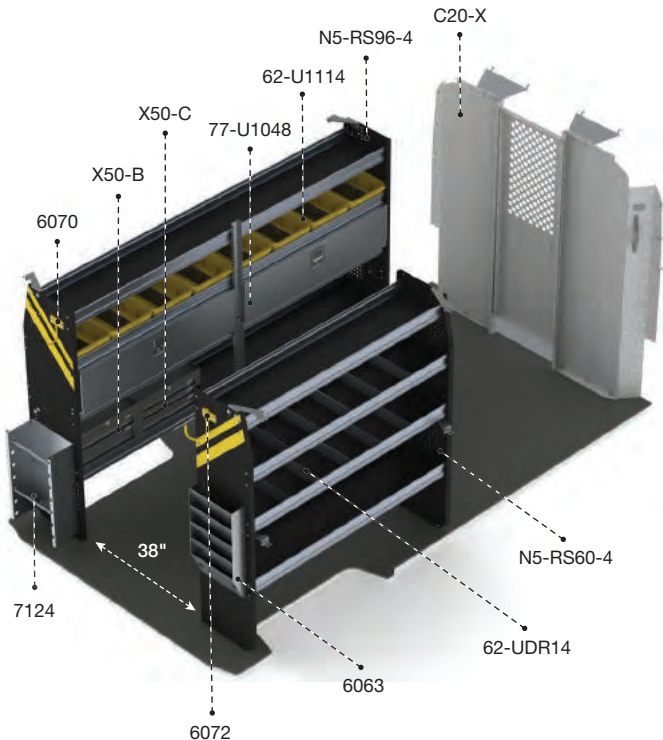

Qty	Part #	Description
1	6063	Paper holder, extra deep, 5 slots
1	6070	6" Hook, 3" opening, painted
1	6072	8" Swivel hook, 4" opening, painted
8	62-U1114	14" Deep plastic bin
2	62-UDR14	Set of 5 dividers for a 14" shelf
1	7124	Reel holder with two 5/8" diameter rods
2	77-U1048	Adjustable shelving door unit - 45" W - for 48" & 96"shelves
1	C20-X	Straight steel partition with perforated window, no access
1	N5-RS60-4	Steel shelving unit for high roof van, 14" D x 60" W x 62" H
1	N5-RS96-4	Steel shelving unit for high roof van, 14" D x 96" W x 62" H
1	X50-B	Compact 2-drawer unit
1	X50-C	Compact 3-drawer unit





VISIT OUR WEBSITE FOR  
OUR FULL-LINE OF PARTITIONS

## RPS-11



### 62-U1110, 62-U1112, 62-U1114

Plastic bins with a center divider  
Available in 10", 12" or 14" depths



### 62-U1212

2 Cross dividers for bin  
Fits all size bins



### 77-U1042

Adjustable shelving door  
unit 39" wide for a 84" shelf

**FOR MORE ACCESSORIES, SEE PAGE 20.**

# RPS-12

118" OR 136" WHEELBASE

> Low or High Roof



Qty	Part #	Description
1	6008	3 Tier refrigerant rack for large bottles
1	6063	Paper holder, extra deep, 5 slots
1	6070	6" Hook, 3" opening, painted
1	6072	8" Swivel hook, 4" opening, painted
1	6088	Large aluminum bottle holder, with two black nylon straps
6	62-U1114	14" Deep plastic bin
2	62-UDR14	Set of 5 dividers for a 14" shelf
1	77-U1048	Adjustable shelving door unit - 45" W - for 48" & 96" shelves
1	C20-X	Straight steel partition with perforated window, no access
1	N5-RS48-4	Steel shelving unit for high roof van, 14" D x 48" W x 62" H
1	N5-RS72-4	Steel shelving unit for high roof van, 14" D x 72" W x 62" H
2	X50-B	Compact 2-drawer unit

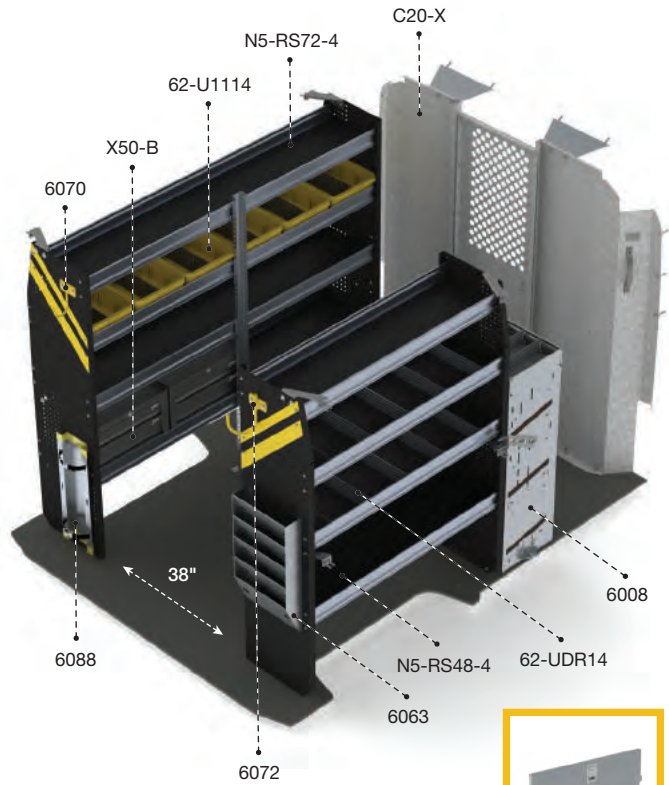

77-U1048

HVAC

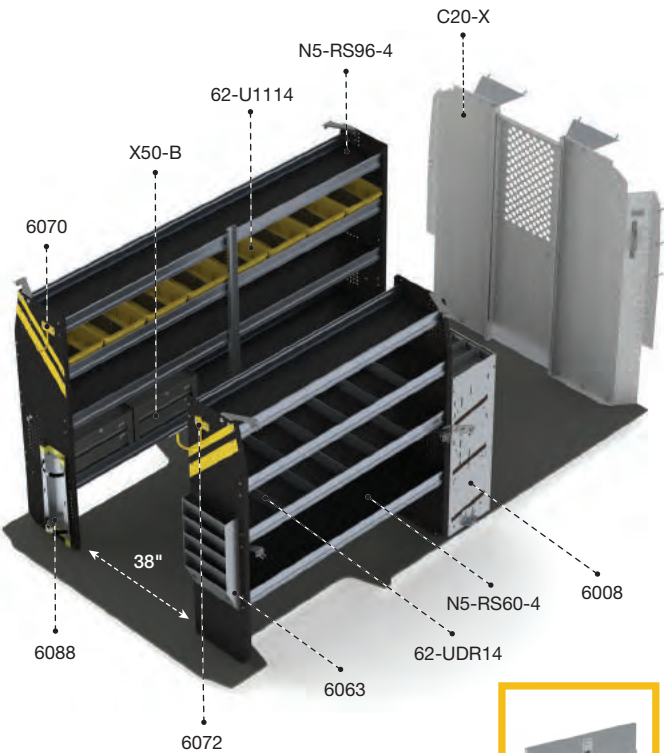

77-U1060

# RPL-12

159" OR 159" EXTENDED WHEELBASE

> High Roof

Qty	Part #	Description
1	6008	3 Tier refrigerant rack for large bottles
1	6063	Paper holder, extra deep, 5 slots
1	6070	6" Hook, 3" opening, painted
1	6072	8" Swivel hook, 4" opening, painted
1	6088	Large aluminum bottle holder, with two black nylon straps
8	62-U1114	14" Deep plastic bin
2	62-UDR14	Set of 5 dividers for a 14" shelf
1	77-U1060	Adjustable shelving door unit - 57" W - for 60" shelves
1	C20-X	Straight steel partition with perforated window, no access
1	N5-RS60-4	Steel shelving unit for high roof van, 14" D x 60" W x 62" H
1	N5-RS96-4	Steel shelving unit for high roof van, 14" D x 96" W x 62" H
2	X50-B	Compact 2-drawer unit





VISIT OUR WEBSITE FOR  
OUR FULL-LINE OF PARTITIONS

# RPS-12



### 62-UDR10, 62-UDR12, 62-UDR14

Set of 5 dividers for a  
10", 12" or 14" shelf

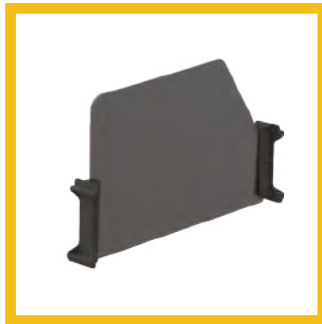

### 62-UDH14

Set of 5 high dividers  
for a 14" shelf



### 6088

Large aluminum bottle holder,  
with two black nylon straps



### 6008

3 Tier refrigerant  
rack for large bottles

FOR MORE ACCESSORIES, SEE PAGE 20.

## RPS-19

118" OR 136" WHEELBASE

> Low or High Roof



Qty	Part #	Description
1	<b>C24-X</b>	Straight walk through steel partition
1	<b>F5-RA72-2</b>	Fold-away unit, 2 levels, 25" D x 72" W x 63" H
1	<b>F5-RA48-2</b>	Fold-away unit, 2 levels, 25" D x 48" W x 63" H

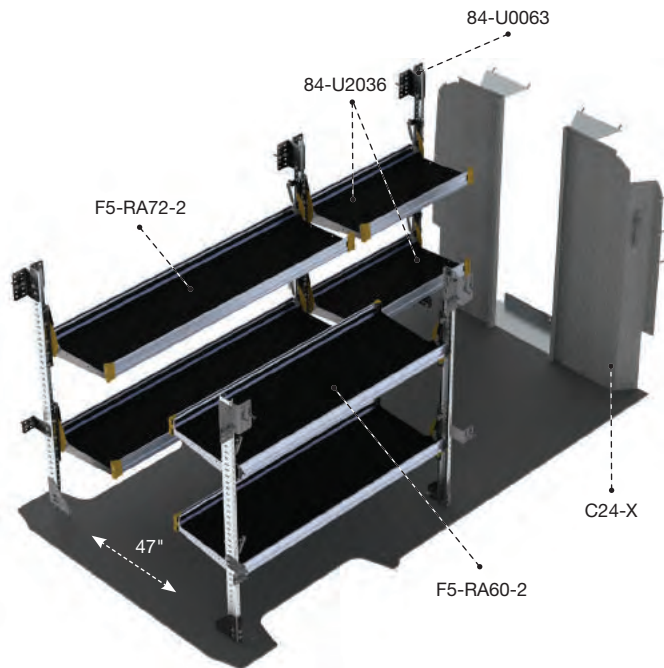
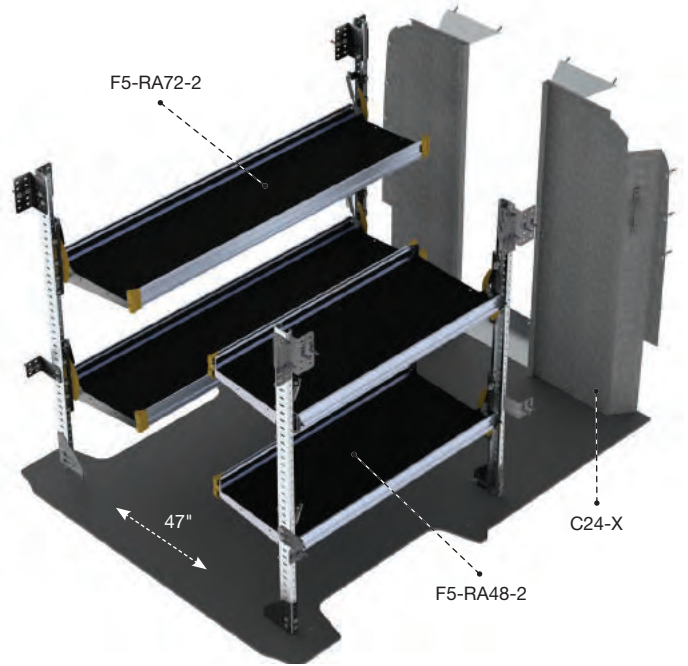

## RPL-19

159" OR 159" EXTENDED WHEELBASE

> High Roof

Qty	Part #	Description
1	<b>C24-X</b>	Straight walk through partition
1	<b>F5-RA60-2</b>	Fold-away unit, 2 levels, 25" D x 60" W x 63" H
1	<b>F5-RA72-2</b>	Fold-away unit, 2 levels, 25" D x 72" W x 63" H
1	<b>84-U0063</b>	Post assembly for fold-away shelving, 63"
2	<b>84-U2036</b>	Fold-away shelf tray, 20" D x 36" W
1	<b>C24-X</b>	Straight walk through steel partition





VISIT OUR WEBSITE FOR  
OUR FULL-LINE OF PARTITIONS

# RPS-19

DELIVERY

## YOUR PERSONAL **FLEX SPACE**

**Our fold-away shelves are designed to give you the ultimate in cargo flexibility**

- Flexible
- Easy to use
- Tough



# ALUMINUM



VISIT OUR WEBSITE FOR  
OUR FULL-LINE OF PARTITIONS

## RPS-27

ALUMINUM

## THE BENEFITS OF **ALUMINUM**

### Weight saving equipment reduces total cost of ownership



Optimize fuel economy by decreasing overall van mass



Reduce vehicle maintenance and repairs caused by weight overload



Increase payload without sacrificing quality – it's a benefit offered only by aluminum



Did you know that for every 100 lbs reduction, you increase fuel economy by 1%?  
[www.fueleconomy.gov](http://www.fueleconomy.gov)

**Ranger Design is the leader for aluminum upfits in North America**



## RPS-27

### 118" OR 136" WHEELBASE

> Low or High Roof



Qty	Part #	Description
1	3020-RP	Countoured safety partition with glass window
1	5010	Partslider 48" D
1	5020	Tool drawer 48" D x 14" W x 16" H
1	5048	Top edge
1	5069-2	2 Drawer cabinet
2	62-U5070	Partskeeper carry case with holder
1	6070	6" Hook, 3" opening, painted
1	6072	8" Swivel hook, 4" opening, painted
4	62-U1112	12" Deep plastic bin
12	62-U1114	14" Deep plastic bin
1	62-UDR12	Set of 5 dividers for a 12" shelf
2	62-UDR14	Set of 5 dividers for a 14" shelf
1	77-U1048	Adjustable shelving door unit - 45" W - for 48" & 96" shelves
1	N5-RA48-4	Aluminum shelving unit for high roof van, 14" D x 48" W x 62" H
1	N5-RA72-4	Aluminum shelving unit for high roof van, 14" D x 72" W x 62" H

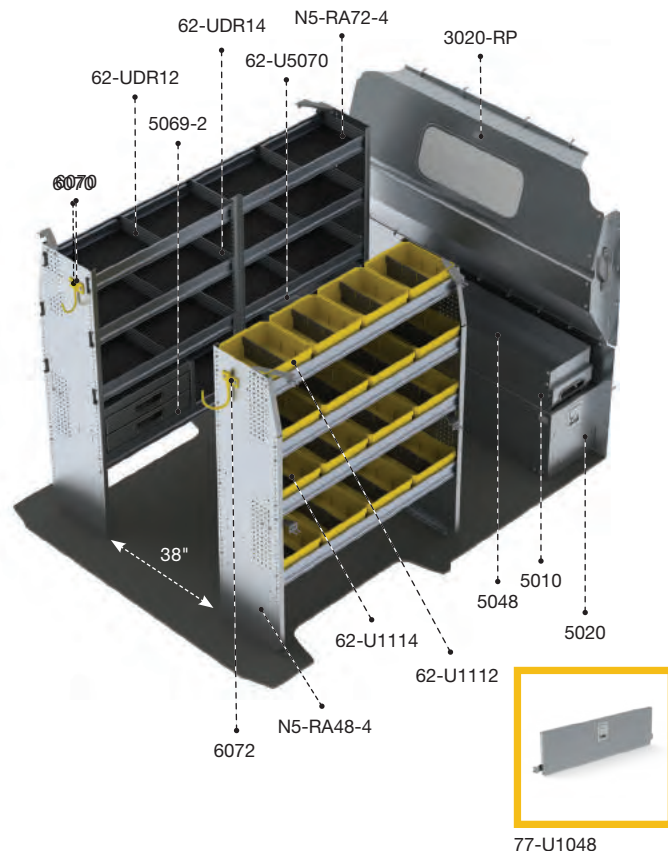

77-U1048

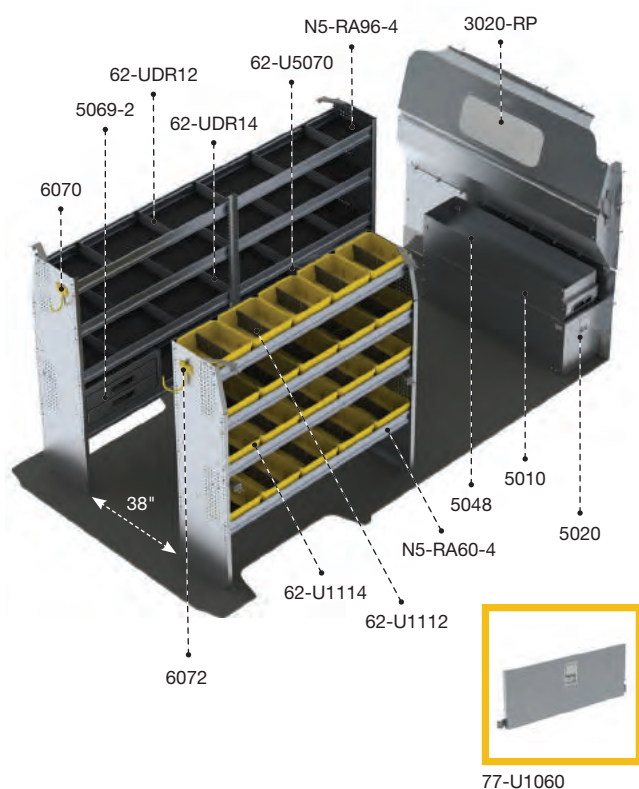

77-U1060

## RPL-27

### 159" OR 159" EXTENDED WHEELBASE

> High Roof

Qty	Part #	Description
1	3020-RP	Countoured safety partition with glass window
1	5010	Partslider 48" D
1	5020	Tool drawer 48" D x 14" W x 16" H
1	5048	Top edge
1	5069-2	2 Drawer cabinet
2	62-U5070	Partskeeper carry case with holder
1	6070	6" Hook, 3" opening, painted
1	6072	8" Swivel hook, 4" opening, painted
5	62-U1112	12" deep plastic bin
15	62-U1114	14" deep plastic bin
1	62-UDR12	Set of 5 dividers for a 12" Shelf
2	62-UDR14	Set of 5 dividers for a 14" Shelf
1	77-U1060	Adjustable shelving door unit - 57" W - for 60" shelves
1	N5-RA60-4	Aluminum Shelving Unit for high roof van, 14" D x 60" W x 62" H
1	N5-RA96-4	Aluminum Shelving Unit for high roof van, 14" D x 96" W x 62" H



# IT'S MORE THAN A FLOOR!

With incorporated mounting tracks for easy install for most Ranger Design products.

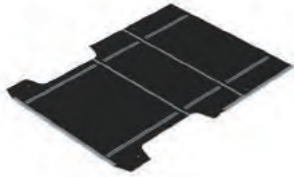

**6540-PS**  
ProMaster 118" Floor

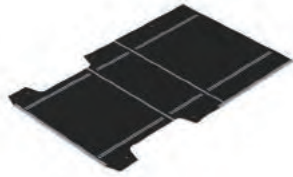

**6540-PM**  
ProMaster 136" Floor

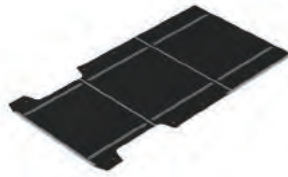

**6540-PL**  
ProMaster 159" Floor

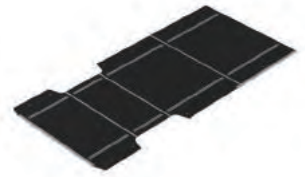

**6540-PX**  
ProMaster 159" Ext. Floor

## DRAWERS

Increase storage and organization with Ranger Design's line of drawer units



**5048**  
Top Edge for drawers



**5020**  
Tool Drawer 48"D x 14"W x 16"H



**5010**  
Partslider Organizer 48"D x 12"W x 6"H



**5025**  
Jumbo tool drawer 48"D x 16"W x 19"H

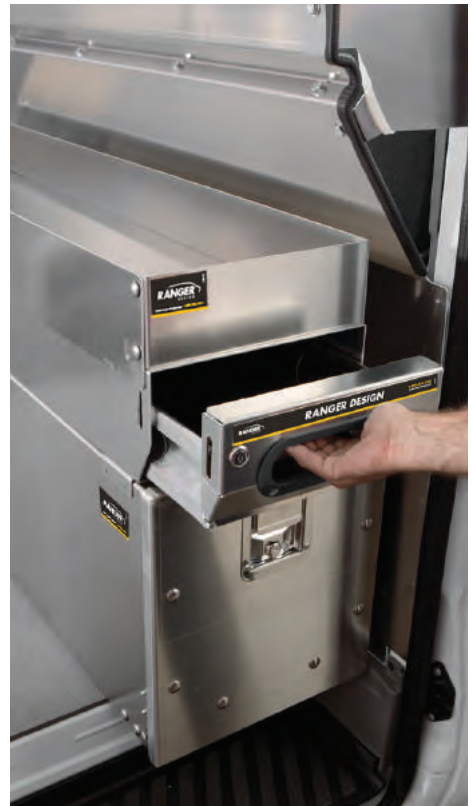

**TOOL DRAWER TIP:** Stack these drawers for the ultimate efficiency



# STORAGE UNITS

Ergonomic storage solutions for the cargo space in your vehicle.



**62-U5079**  
Partskeeper carry case



CAN BE INSTALLED EITHER WAY



**62-U5070**  
Partskeeper carry case with holder, universal



**62-U5074**  
Partskeeper floor mount cabinet with 4 carry cases, universal



**N5-PS20-8**  
Partskeeper cabinet with 8 carry cases & 2 shelves, universal



**N5-LS16-1**  
Locker with top shelf, 16" D x 16" W x 63" H



**S3-WA48-0**  
Workbench, with hardwood top, one end panel, Universal (drawer cabinet not included)



5060-5



**S3-WA48-1**  
Workbench, aluminum with hardwood top, 1 shelf tray, Universal

# ACCESSORIES

Choose the finishing details to tailor the upfit to your specific needs.



## CARGO HOLDERS

Increase organization by giving a specific spot to store your equipment. Instead of being loose on the floor, your reels, cans etc. can be secured within easy reach from the door.



**6010**  
Two level adjustable bottle holder



**6057**  
Can holder



**6068**  
Hard hat holder, painted wire



**7124**  
Reel holder with two 5/8" diameter rods

## STORAGE HOOKS

Keep frequently used items such as hats, vests and extension cords hanging within easy reach while on the road.



**6070**  
6" Hook, 3" opening, painted



**6073**  
Large aluminum movable hook, 6.5" opening

## MAX STEP

Climbing in and out of your van several times a day can put a strain on your legs and back. The Max Step steps give tradesmen quick and easy access to their cargo space.



**6550-FT**  
Max Step

## SEAT COVERS

Keep your cab looking just like new with tight custom fit seat covers. The water & stain resistant fabric keeps your seats looking clean and increases resale value.



**6255**  
Seat covers

## LED LIGHTING

Keeps the cargo space bright, making visibility easy, no matter what time of day or night. Eliminate any chance of injury when searching through your tools in the dark.



**6092-42**  
Universal LED light kit for trucks and vans (12V DC / 1200 Lm / 10W)

## GRAB HANDLE

It is always useful to have something to hold onto when climbing into your van. Grab handles can also be used to tie down extra cargo during transport.



**6093-27**  
Large grab handle

## WINDOW GRILLS

Protect your van against theft and prevent damage to the van during loading or unloading, with Ranger Design's window grills.

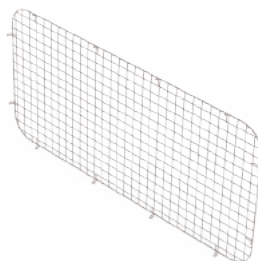

**6118**  
Window grill, passenger side door

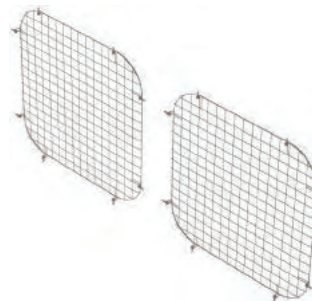

**6119**  
Set of 2 rear window grills



**STAY SAFE WITH RANGER DESIGN'S COMMERCIAL VEHICLE ACCESSORIES**

# LADDER RACKS



Cargo + rack



## Aluminum

			
<b>1506-PHS</b>	118"	Standard	—
<b>1506-PHM</b>	136"	Low, High	—
<b>1506-PHL</b>	159"	Medium, High	—
<b>1506-PHX</b>	159" Ext	High	—



Standard ladder rack



## Aluminum

				
<b>1510-PH</b>	2 Bars	118", 136", 159", 159" Ext	Standard, High	—
<b>1510-PH3</b>	3 Bars	118", 136", 159", 159" Ext	Standard, High	—



Double clamp ladder rack



## Aluminum

			
<b>1530-PHS</b>	118"	Standard	28 ft
<b>1530-PHM</b>	136"	Standard, High	32 ft
<b>1530-PHL</b>	159"	High	32 ft
<b>1530-PHX</b>	159" Ext	High	32 ft



Double clamp ladder rack



## Aluminum

			
<b>1530-PHS3</b>	118"	Standard	28 ft
<b>1530-PHM3</b>	136"	Standard, High	32 ft
<b>1530-PHL3</b>	159"	High	32 ft
<b>1530-PHX3</b>	159" Ext	High	32 ft



Max Rack 2.0, Single side ladder rack



## Aluminum

			
<b>1870-PHS</b>	118"	Standard	28 ft
<b>1870-PHM</b>	136"	Standard, High	32 ft
<b>1870-PHL</b>	159"	High	32 ft
<b>1870-PHX</b>	159" Ext	High	32 ft



Max Rack 2.0, Double side ladder rack

## Aluminum

			
<b>1880-PHS</b>	118"	Standard	28 ft
<b>1880-PHM</b>	136"	Standard, High	32 ft
<b>1880-PHL</b>	159"	High	32 ft
<b>1880-PHX</b>	159" Ext	High	32 ft

# Turn-Key Fleet Services



## A Leader in Fleet Upfitting in North America

Our Proven Process to Deliver a Better Experience for Fleets:

### 1. Analysis

- › Cargo Needs Analysis
- › Custom 3D CAD Layouts
- › Hands-on Equipment Demo

### 2. Testing

- › Test Fitting
- › Pilot Build and Review
- › Package optimization based on technician feedback

### 3. Delivery

- › Delivery, production, installation planning and scheduling
- › Vehicle Status Tracking

### 4. Service

- › Dedicated Fleet Account Management Team
- › Ranger Design Distributor Service Support Network
- › Live Customer Service

**Ship Through or Local Installation Across the continent for all Types of Cargo Vans**

**THE PERFECT FIT**  
FOR YOUR  
**TOUGHEST JOBS**

When you want the **perfect upfit solution** for your work vehicle, turn to Ranger Design. **Tested for toughness**, Ranger Design's shelving and upfits will take whatever abuse you can dish out. Their **unsurpassed craftsmanship**, combined with ideal fit and finish, provide **a quiet ride with no rattles**.



**CUSTOMER SERVICE**

cs@rangerdesign.com  
1-800-565-5321

rangerdesign.com

