

## SERVICE BODY SPECIFICATION 37" CA - L, S and T-Series

### Body Shell

- Body sides, bulkhead, and tailgate are constructed of 14 gauge A40 galvanized steel.
- One piece compartment top and back.
- Die formed seamless fenders.

### Floor

- 12 gauge medium pattern treadplate floor.

### Understructure

- 5-1/4" high 3/16" formed steel crossmembers at the front of the body.
- 2" x 3" high 10 gauge formed steel extension U-shaped crossmembers.
- 4-3/4" high 3/16" formed steel crossmembers at the rear of the body.
- 3 full-length formed 14 gauge steel "C" channel longitudinals.

### Doors

- Double panel doors with 14 gauge galvanized steel outer panel and 18 gauge corrugated inner panel.
- Door design includes a knife edge for continuous positive contact with the door seal.
- A full size, stainless steel paddle handle rotary latch is recessed into each door of the body.

### Rear Body Reinforcing Member

- 12 gauge "hat" channel reinforcement across the rear of the body.

### Hinge Pins and Hinges

- Doors incorporate 5/16" diameter stainless steel rod hinge pins.
- Stainless steel pillow block hinges include self-lubricating plastic bushings.
- Hinge pillow blocks are attached to the body side with closed end pop rivets as standard. Body can be ordered with hinges welded as an option.

### Door Retainers

- Spring loaded door retainers on vertical doors are easily detachable to allow the door to swing 180°.
- Heavy-duty chain supports on the horizontal doors are easily removable to allow the door to drop down.

### Door Seals

- Automotive type square-bulb seal installs in a full perimeter protective channel. Seal is unbroken at the striker.

### Shelving

- Shelving and compartment partitions are removable allowing for the creation of various compartment interior arrangements.
- 4 full-height compartment partitions are furnished as standard. Half-height partitions are available as an option.
- Compartment shelving is adjustable on 2" centers.
- 16 gauge galvanized steel shelves are slotted for dividers on 2" centers.
- 20 fully folded dividers for compartment shelving.
- Top opening compartments are slotted on 2" centers for dividers.
- 16 additional fully folded dividers for top opening models.
- Material hook bar assembly with 3 hooks.

### Tailgate

- 11-1/2" high.
- One-hand opening, slam close.
- Center release stainless steel latch.

### Prime Paint

- All body components receive a with a five-stage state-of-the-art metal pretreatment and baked on primer.
- A second primer coating is applied after final body assembly for maximum corrosion resistance.

### Undercoating

- Entire body underside is fully undercoated with an automotive grade undercoating.

### Mounting Kit

- Mounting Kit furnished as standard.

### Warranty

Lifetime Warranty applies to anything we have manufactured. Refer to written warranty page for details.

# Floor Understructure for L, S and T-Series 37" CA Service Bodies

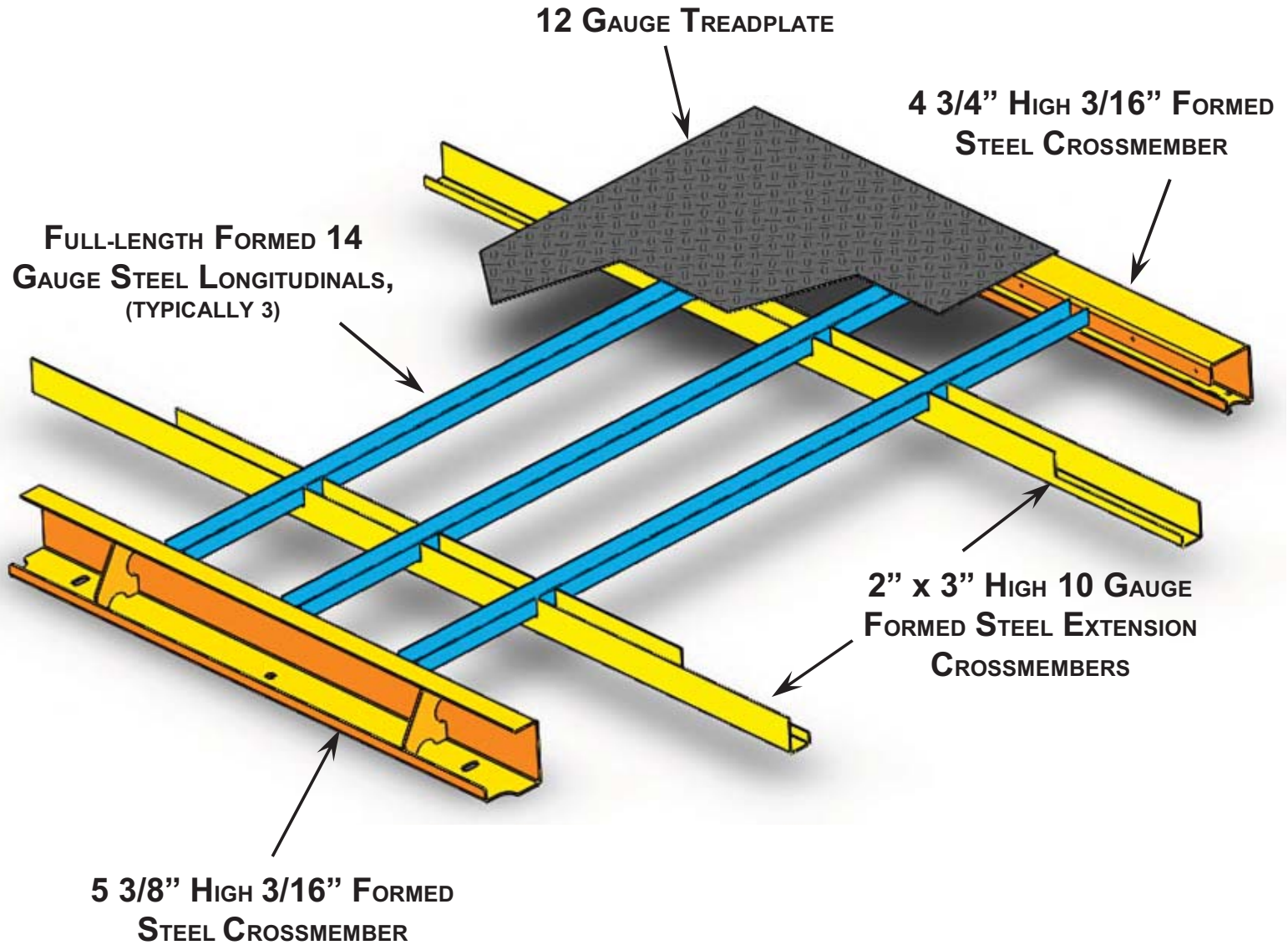



## SERVICE BODY SPECIFICATION 40" & 42" CA - L, S and T-Series

### Body Shell

- Body sides, bulkhead, and tailgate are constructed of 14 gauge A40 galvanized steel.
- One piece compartment top and back.
- Die formed seamless fenders.

### Floor

- 12 gauge medium pattern treadplate floor.

### Understructure

- 5-1/4" high 3/16" formed steel crossmembers at the front of the body.
- 2" x 3" high 10 gauge formed steel extension U-shaped crossmembers.
- 4-3/4" high 3/16" formed steel crossmembers at the rear of the body.
- 3 full-length formed 14 gauge steel "C" channel longitudinals.

### Doors

- Double panel doors with 14 gauge galvanized steel outer panel and 18 gauge corrugated inner panel.
- Door design includes a knife edge for continuous positive contact with the door seal.
- A full size, stainless steel paddle handle rotary latch is recessed into each door of the body.

### Rear Body Reinforcing Member

- 12 gauge "hat" channel reinforcement across the rear of the body.

### Hinge Pins and Hinges

- Doors incorporate 5/16" diameter stainless steel rod hinge pins.
- Stainless steel pillow block hinges include self-lubricating plastic bushings.
- Hinge pillow blocks are attached to the body side with closed end pop rivets as standard. Body can be ordered with hinges welded as an option.

### Door Retainers

- Spring loaded door retainers on vertical doors are easily detachable to allow the door to swing 180°.
- Heavy-duty chain supports on the horizontal doors are easily removable to allow the door to drop down.

### Door Seals

- Automotive type square-bulb seal installs in a full perimeter protective channel. Seal is unbroken at the striker.

### Shelving

- Shelving and compartment partitions are removable allowing for the creation of various compartment interior arrangements.
- 4 full-height compartment partitions are furnished as standard. Half-height partitions are available as an option.
- Compartment shelving is adjustable on 2" centers.
- 16 gauge galvanized steel shelves are slotted for dividers on 2" centers.
- 20 fully folded dividers for compartment shelving.
- Top opening compartments are slotted on 2" centers for dividers.
- 16 additional fully folded dividers for top opening models.
- Material hook bar assembly with 3 hooks.

### Tailgate

- 11-1/2" high.
- One-hand opening, slam close.
- Center release stainless steel latch.

### Prime Paint

- All body components receive a with a five-stage state-of-the-art metal pretreatment and baked on primer.
- A second primer coating is applied after final body assembly for maximum corrosion resistance.

### Undercoating

- Entire body underside is fully undercoated with an automotive grade undercoating.

### Mounting Kit

- Mounting Kit furnished as standard.

### Warranty

Lifetime Warranty applies to anything we have manufactured. Refer to written warranty page for details.

Revised 12/2021

In order to provide the most innovative and progressive equipment, all specifications and designs are subject to change without notice.

# Floor Understructure for L, S and T-Series 40" & 42" CA Service Bodies

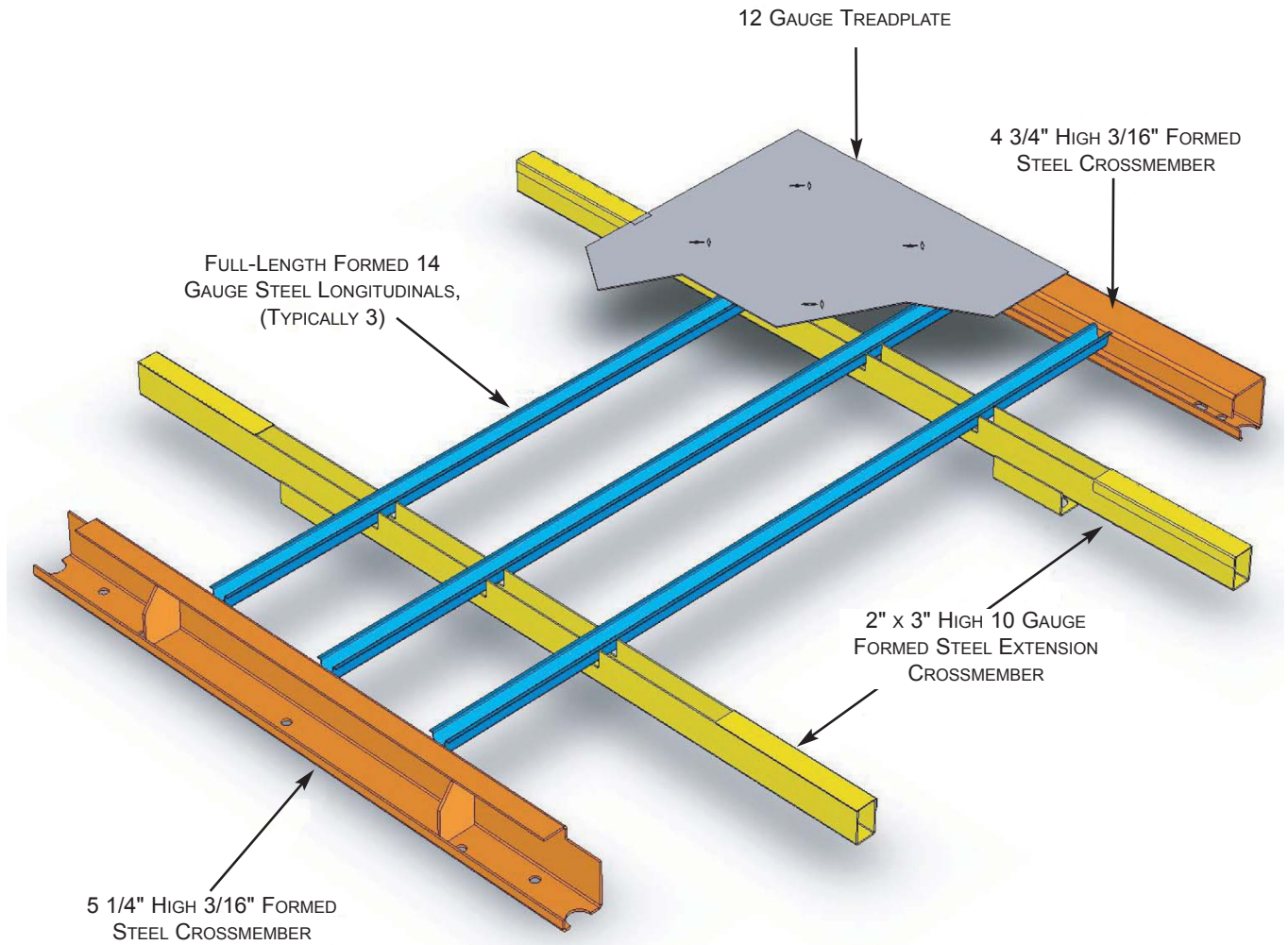



## SERVICE BODY SPECIFICATION 56" CA - J, L, S, T and U-Series

### Body Shell

- Body sides, bulkhead, and tailgate are constructed of 14 gauge A40 galvanized steel.
- One piece compartment top and back.
- Die formed seamless fenders.

### Floor

- 12 gauge medium pattern treadplate floor.

### Understructure

- 5-1/4" high 3/16" formed steel crossmembers at the front of the body.
- 2" x 3" high 10 gauge formed steel extension U-shaped crossmembers.
- 4-3/4" high 3/16" formed steel crossmembers at the rear of the body.
- 3 full-length formed 14 gauge steel "C" channel longitudinals.

### Doors

- Double panel doors with 14 gauge galvanized steel outer panel and 18 gauge corrugated inner panel.
- Door design includes a knife edge for continuous positive contact with the door seal.
- A full size, stainless steel paddle handle rotary latch is recessed into each door of the body.

### Rear Body Reinforcing Member

- 12 gauge "hat" channel reinforcement across the rear of the body.

### Hinge Pins and Hinges

- Doors incorporate 5/16" diameter stainless steel rod hinge pins.
- Stainless steel pillow block hinges include self-lubricating plastic bushings.
- Hinge pillow blocks are attached to the body side with closed end pop rivets as standard. Body can be ordered with hinges welded as an option.

### Door Retainers

- Spring loaded door retainers on vertical doors are easily detachable to allow the door to swing 180°.
- Heavy-duty chain supports on the horizontal doors are easily removable to allow the door to drop down.

### Door Seals

- Automotive type square-bulb seal installs in a full perimeter protective channel. Seal is unbroken at the striker.

### Shelving

- Shelving and compartment partitions are removable allowing for the creation of various compartment interior arrangements.
- 4 full-height compartment partitions are furnished as standard. Half-height partitions are available as an option.
- Compartment shelving is adjustable on 2" centers.
- 16 gauge galvanized steel shelves are slotted for dividers on 2" centers.
- 20 fully folded dividers for compartment shelving.
- Top opening compartments are slotted on 2" centers for dividers.
- 16 additional fully folded dividers for top opening models.
- Material hook bar assembly with 3 hooks.

### Tailgate

- 11-1/2" high.
- One-hand opening, slam close.
- Center release stainless steel latch.

### Prime Paint

- All body components receive a with a five-stage state-of-the-art metal pretreatment and baked on primer.
- A second primer coating is applied after final body assembly for maximum corrosion resistance.

### Undercoating

- Entire body underside is fully undercoated with an automotive grade undercoating.

### Mounting Kit

- Mounting Kit furnished as standard.

### Warranty

Lifetime Warranty applies to anything we have manufactured. Refer to written warranty page for details.

Revised 12/2021

In order to provide the most innovative and progressive equipment, all specifications and designs are subject to change without notice.



# Floor Understructure for L, S, T, J and U 56" CA Service Bodies

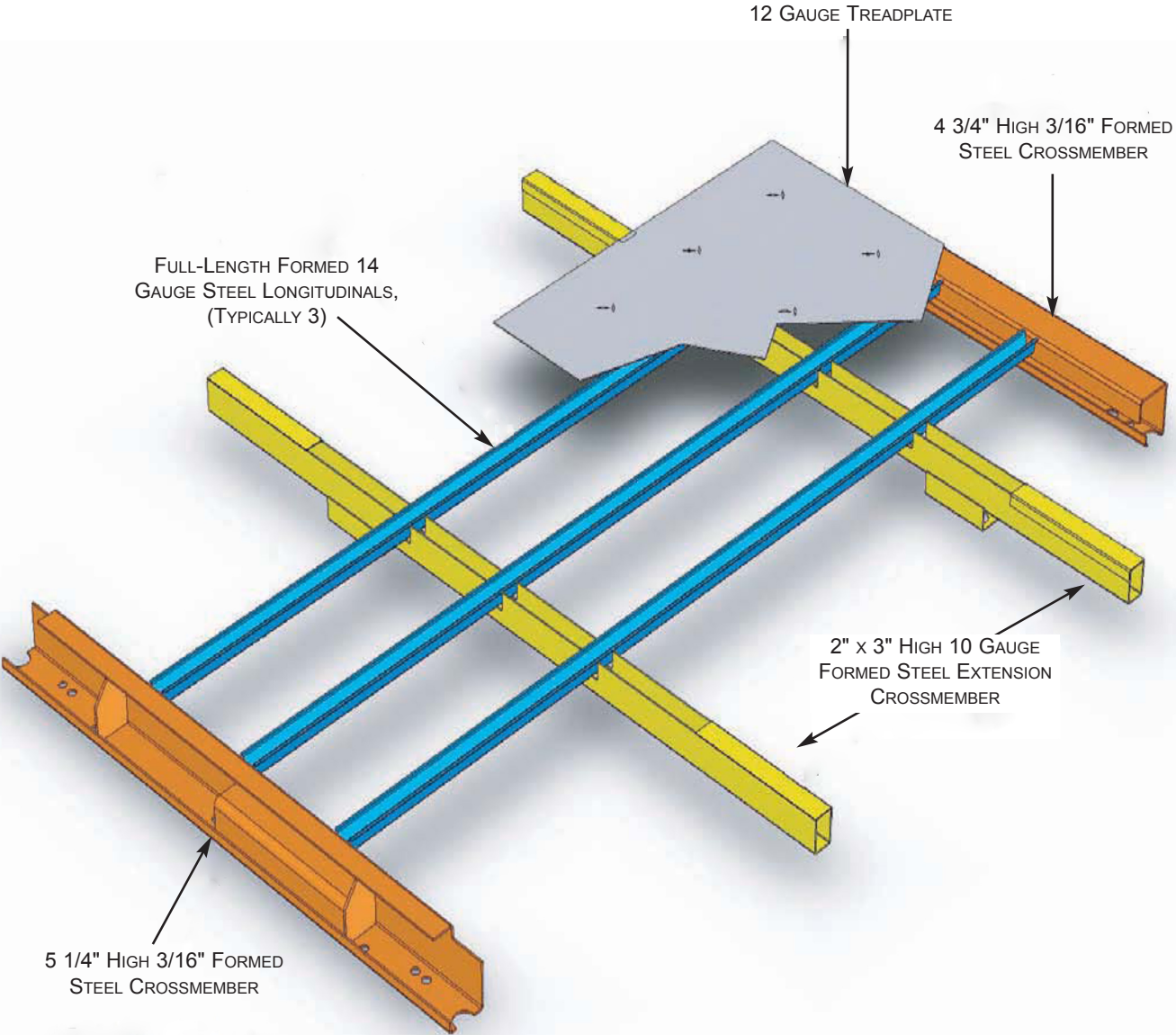



## SERVICE BODY SPECIFICATION 57" CA - L and T-Series

### Body Shell

- Body sides, bulkhead, and tailgate are constructed of 14 gauge A40 galvanized steel.
- One piece compartment top and back.
- Die formed seamless fenders.

### Floor

- 12 gauge medium pattern treadplate floor.

### Understructure

- 5-1/4" high 3/16" formed steel crossmembers at the front of the body.
- 2" x 3" high 10 gauge formed steel extension U-shaped crossmembers.
- 4-3/4" high 3/16" formed steel crossmembers at the rear of the body.
- 3 full-length formed 14 gauge steel "C" channel longitudinals.

### Doors

- Double panel doors with 14 gauge galvanized steel outer panel and 18 gauge corrugated inner panel.
- Door design includes a knife edge for continuous positive contact with the door seal.
- A full size, stainless steel paddle handle rotary latch is recessed into each door of the body.

### Rear Body Reinforcing Member

- 12 gauge "hat" channel reinforcement across the rear of the body.

### Hinge Pins and Hinges

- Doors incorporate 5/16" diameter stainless steel rod hinge pins.
- Stainless steel pillow block hinges include self-lubricating plastic bushings.
- Hinge pillow blocks are attached to the body side with closed end pop rivets as standard. Body can be ordered with hinges welded as an option.

### Door Retainers

- Spring loaded door retainers on vertical doors are easily detachable to allow the door to swing 180°.
- Heavy-duty chain supports on the horizontal doors are easily removable to allow the door to drop down.

### Door Seals

- Automotive type square-bulb seal installs in a full perimeter protective channel. Seal is unbroken at the striker.

### Shelving

- Shelving and compartment partitions are removable allowing for the creation of various compartment interior arrangements.
- 4 full-height compartment partitions are furnished as standard. Half-height partitions are available as an option.
- Compartment shelving is adjustable on 2" centers.
- 16 gauge galvanized steel shelves are slotted for dividers on 2" centers.
- 20 fully folded dividers for compartment shelving.
- Top opening compartments are slotted on 2" centers for dividers.
- 16 additional fully folded dividers for top opening models.
- Material hook bar assembly with 3 hooks.

### Tailgate

- 11-1/2" high.
- One-hand opening, slam close.
- Center release stainless steel latch.

### Prime Paint

- All body components receive a five-stage state-of-the-art metal pretreatment and baked on primer.
- A second primer coating is applied after final body assembly for maximum corrosion resistance.

### Undercoating

- Entire body underside is fully undercoated with an automotive grade undercoating.

### Mounting Kit

- Mounting Kit furnished as standard.

### Warranty

Lifetime Warranty applies to anything we have manufactured. Refer to written warranty page for details.

Revised 12/2021

In order to provide the most innovative and progressive equipment, all specifications and designs are subject to change without notice.

# Floor Understructure for L and T-Series 57" CA Service Bodies

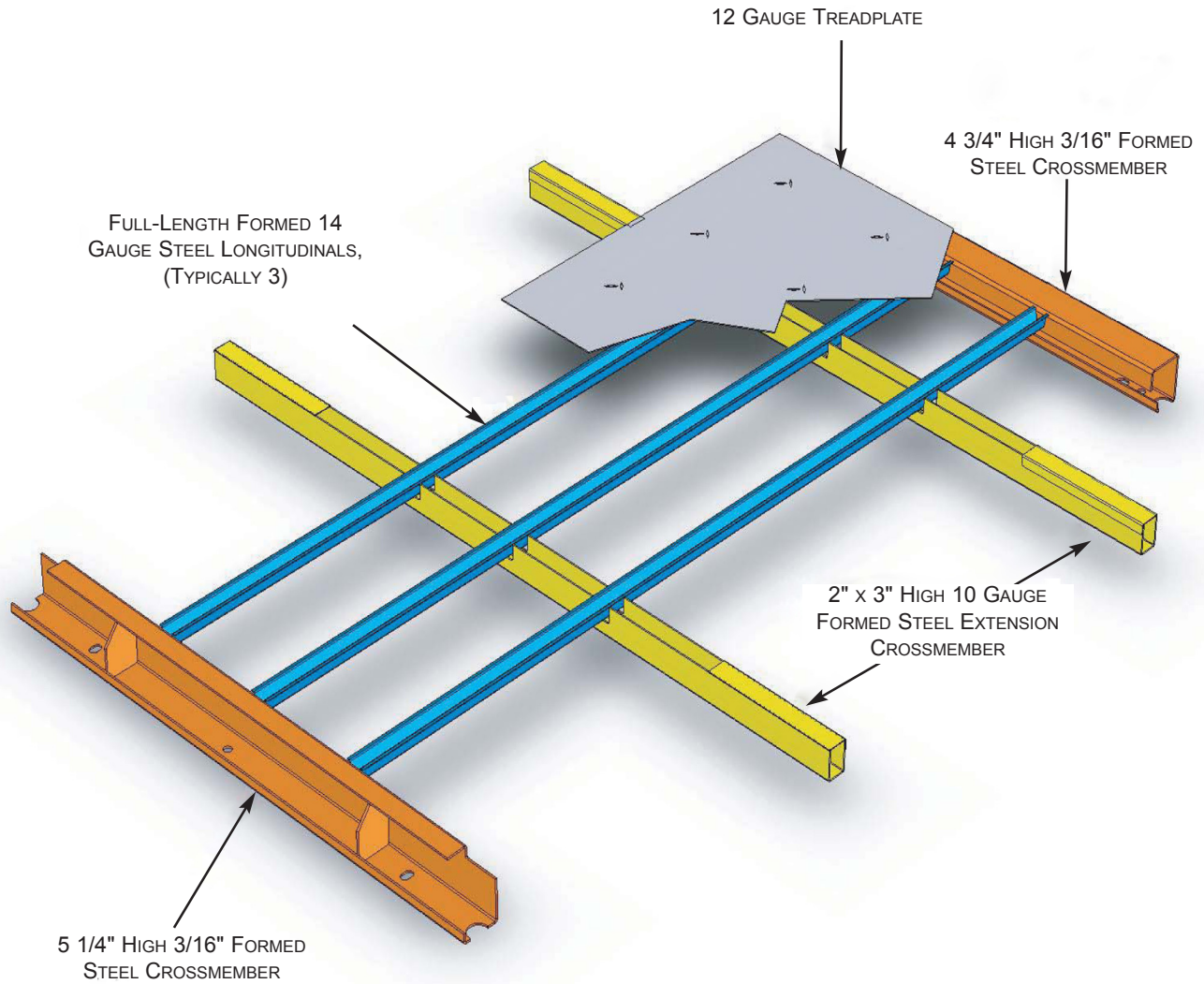





## SERVICE BODY SPECIFICATION

### 60" CA Single Rear Wheel - J, L, S, T and U-Series

#### Body Shell

- Body sides, bulkhead, and tailgate are constructed of 14 gauge A40 galvanized steel.
- One piece compartment top and back.
- Die formed seamless fenders.

#### Floor

- 12 gauge medium pattern treadplate floor.

#### Understructure

- 5" high 3/16" formed steel crossmembers at the front and rear of the body.
- 2" x 3" high 10 gauge formed steel extension U-shaped crossmembers.
- 5" high 10 gauge formed steel intermediate crossmembers.
- 3 full-length formed 14 gauge steel "C" channel longitudinals.

#### Doors

- Double panel doors with 14 gauge galvanized steel outer panel and 18 gauge corrugated inner panel.
- Door design includes a knife edge for continuous positive contact with the door seal.
- A full size, stainless steel paddle handle rotary latch is recessed into each door of the body.

#### Rear Body Reinforcing Member

- 12 gauge "hat" channel reinforcement across the rear of the body.

#### Hinge Pins and Hinges

- Doors incorporate 5/16" diameter stainless steel rod hinge pins.
- Stainless steel pillow block hinges include self-lubricating plastic bushings.
- Hinge pillow blocks are attached to the body side with closed end pop rivets as standard. Body can be ordered with hinges welded as an option.

#### Door Retainers

- Spring loaded door retainers on vertical doors are easily detachable to allow the door to swing 180°.
- Heavy-duty chain supports on the horizontal doors are easily removable to allow the door to drop down.

#### Door Seals

- Automotive type square-bulb seal installs in a full perimeter protective channel. Seal is unbroken at the striker.

#### Shelving

- Shelving and compartment partitions are removable allowing for the creation of various compartment interior arrangements.
- 4 full-height compartment partitions are furnished as standard. Half-height partitions are available as an option.
- Compartment shelving is adjustable on 2" centers.
- 16 gauge galvanized steel shelves are slotted for dividers on 2" centers.
- 20 fully folded dividers for compartment shelving.
- Top opening compartments are slotted on 2" centers for dividers.
- 16 additional fully folded dividers for top opening models.
- Material hook bar assembly with 3 hooks.

#### Tailgate

- 11-1/2" high.
- One-hand opening, slam close.
- Center release stainless steel latch.

#### Prime Paint

- All body components receive a five-stage state-of-the-art metal pretreatment and baked on primer.
- A second primer coating is applied after final body assembly for maximum corrosion resistance.

#### Undercoating

- Entire body underside is fully undercoated with an automotive grade undercoating.

#### Mounting Kit

- Mounting Kit furnished as standard.

#### Warranty

Lifetime Warranty applies to anything we have manufactured. Refer to written warranty page for details.

Revised 12/2021

In order to provide the most innovative and progressive equipment, all specifications and designs are subject to change without notice.

# Floor Understructure for J, L, S, T and U-Series 60" CA Single Rear Wheel Service Bodies

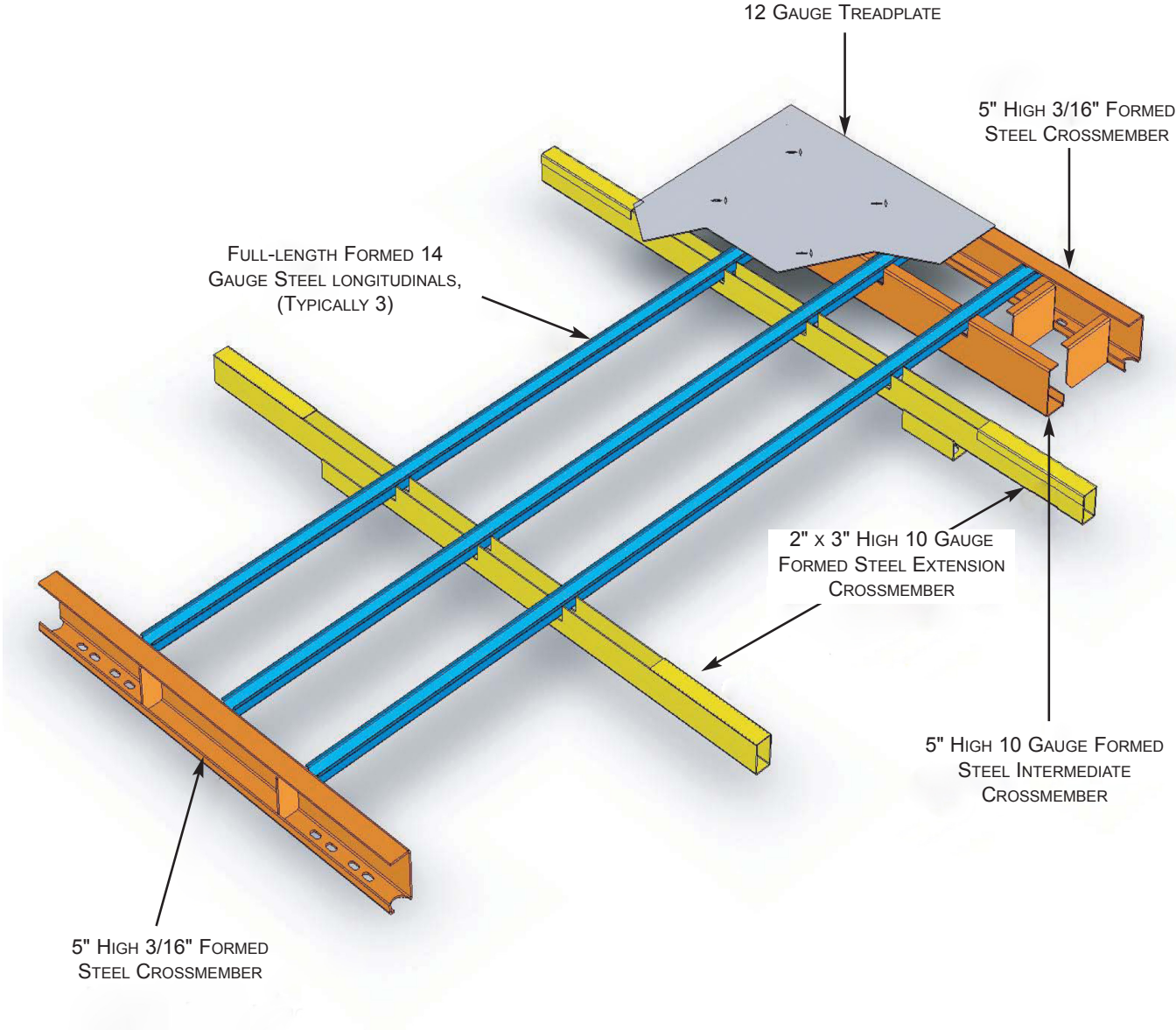



## SERVICE BODY SPECIFICATION

### 60" CA or Larger Dual Rear Wheel - J, L, S, T and U-Series

#### Body Shell

- Body sides, bulkhead, and tailgate are constructed of 14 gauge A40 galvanized steel.
- One piece compartment top and back. (Bodies up to 144" long.)
- Die formed seamless fenders.

#### Floor

- 12 gauge medium pattern treadplate floor.

#### Understructure

- 4" high 3/16" formed steel crossmembers at the front and rear of the body.
- 4" high 10 gauge formed steel intermediate and extension crossmembers.
- 3 full-length formed 14 gauge steel "C" channel longitudinals.

#### Doors

- Double panel doors with 14 gauge galvanized steel outer panel and 18 gauge corrugated inner panel.
- Door design includes a knife edge for continuous positive contact with the door seal.
- A full size, stainless steel paddle handle rotary latch is recessed into each door of the body.

#### Rear Body Reinforcing Member

- 12 gauge "hat" channel reinforcement across the rear of the body.

#### Hinge Pins and Hinges

- Doors incorporate 5/16" diameter stainless steel rod hinge pins.
- Stainless steel pillow block hinges include self-lubricating plastic bushings.
- Hinge pillow blocks are attached to the body side with closed end pop rivets as standard. Body can be ordered with hinges welded as an option.

#### Door Retainers

- Spring loaded door retainers on vertical doors are easily detachable to allow the door to swing 180°.
- Heavy-duty chain supports on the horizontal doors are easily removable to allow the door to drop down.

#### Door Seals

- Automotive type square-bulb seal installs in a full perimeter protective channel. Seal is unbroken at the striker.

#### Shelving

- Shelving and compartment partitions are removable allowing for the creation of various compartment interior arrangements.
- 4 full-height compartment partitions are furnished as standard. Half-height partitions are available as an option.
- Compartment shelving is adjustable on 2" centers.
- 16 gauge galvanized steel shelves are slotted for dividers on 2" centers.
- 20 fully folded dividers for compartment shelving.
- Top opening compartments are slotted on 2" centers for dividers.
- 16 additional fully folded dividers for top opening models.
- Material hook bar assembly with 3 hooks.

#### Tailgate

- 11-1/2" high.
- One-hand opening, slam close.
- Center release stainless steel latch.

#### Prime Paint

- All body components receive a five-stage state-of-the-art metal pretreatment and baked on primer.
- A second primer coating is applied after final body assembly for maximum corrosion resistance.

#### Undercoating

- Entire body underside is fully undercoated with an automotive grade undercoating.

#### Mounting Kit

- Mounting Kit furnished as standard.

#### Warranty

Lifetime Warranty applies to anything we have manufactured. Refer to written warranty page for details.

Revised 12/2021

In order to provide the most innovative and progressive equipment, all specifications and designs are subject to change without notice.

## Floor Understructure for J, L, S, T and U-Series 60" CA or Larger Dual Rear Wheel Service Bodies

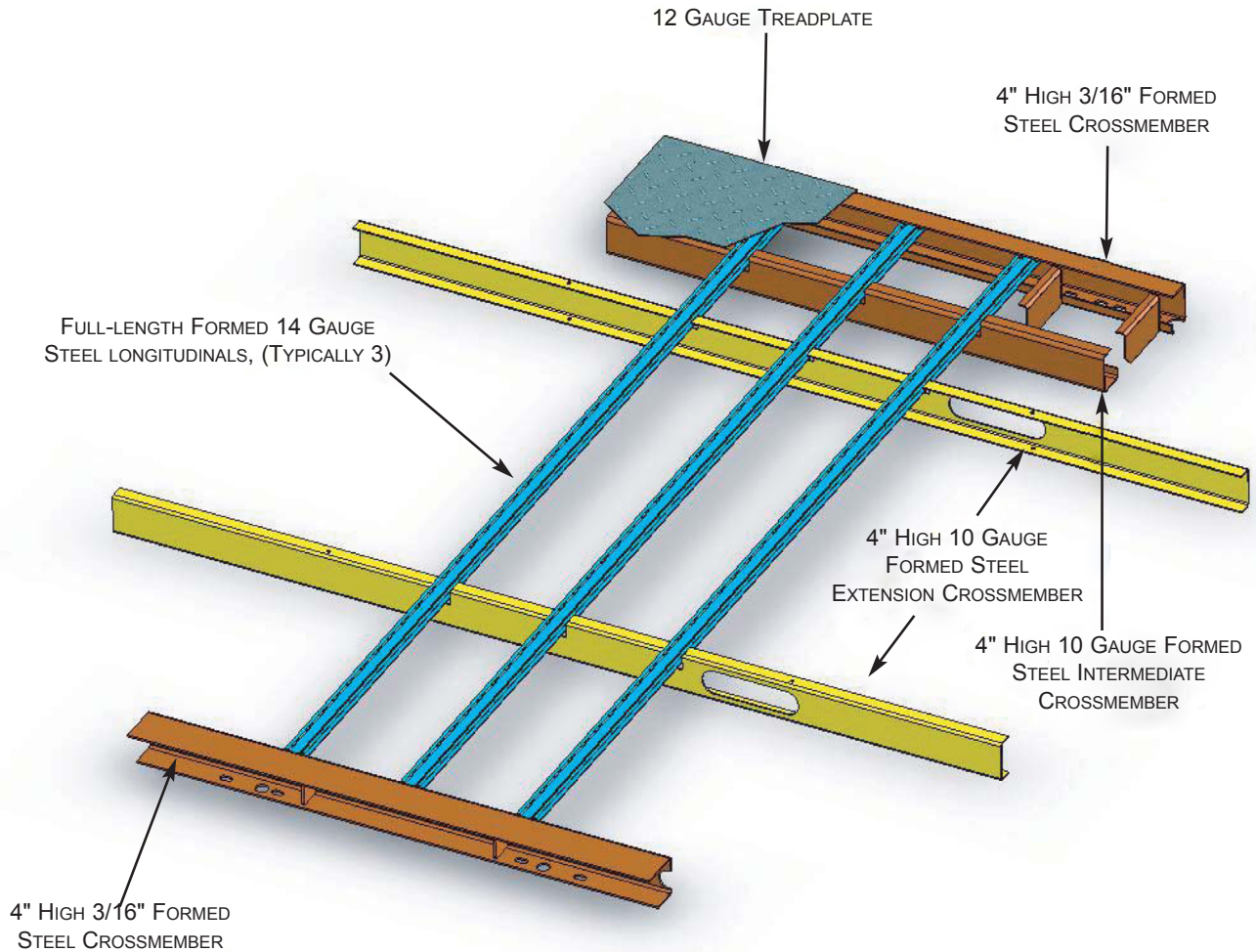

Understructure shown is for 60" CA and 108" floor length

Crossmembers are re-spaced or added as required to maintain structural integrity for longer floors

84" CA and 132" long floor has 1 additional intermediate crossmember  
108" CA and 156" long floor has 5 additional intermediate crossmembers  
120" CA and 168" long floor has 6 additional intermediate crossmembers



## SERVICE BODY SPECIFICATION 60" CA or Larger Dual Rear Wheel – A-Series

### Body Shell

- Body sides, bulkhead, and tailgate are constructed of 14 gauge A40 galvanized steel.
- One piece compartment top and back. (Bodies up to 144" long.)
- Die formed seamless fenders.

### Floor

- 1/8" medium pattern treadplate floor.

### Understructure

- 6" high 8.2# structural steel front, rear and extension crossmembers.
- 6" high 3/16" formed steel intermediate crossmembers.
- 3 full-length 12 gauge formed steel "C" channel longitudinals.
- 1/2" x 3" steel flatbar long runners.

### Doors

- Double panel doors with 14 gauge galvanized steel outer panel and 18 gauge corrugated inner panel.
- Door design includes a knife edge for continuous positive contact with the door seal.
- A full size, stainless steel paddle handle rotary latch is recessed into each door of the body.

### Hinge Pins and Hinges

- Doors incorporate 5/16" diameter stainless steel rod hinge pins.
- Stainless steel pillow block hinges include self-lubricating plastic bushings.
- Hinge pillow blocks are attached to the body side with closed end pop rivets as standard. Body can be ordered with hinges welded as an option.

### Door Retainers

- Spring loaded door retainers on vertical doors are easily detachable to allow the door to swing 180°.

### Door Seals

- Automotive type square-bulb seal installs in a full perimeter protective channel. Seal is unbroken at the striker.

### Shelving

- 4 full-height compartment partitions are furnished as standard. Half-height partitions are available as an option.
- Shelving package is optional on A-Series bodies.

### Prime Paint

- All body components receive a five-stage state-of-the-art metal pretreatment and baked on primer.
- A second primer coating is applied after final body assembly for maximum corrosion resistance.

### Undercoating

- Entire body underside is fully undercoated with an automotive grade undercoating.

### Mounting Kit

- Mounting kit is optional on A-Series bodies.

### Warranty

Lifetime Warranty applies to anything we have manufactured. Refer to written warranty page for details.

Revised 12/2021

In order to provide the most innovative and progressive equipment, all specifications and designs are subject to change without notice.



# Heavy-Duty Floor Understructure for A-Series Service Bodies

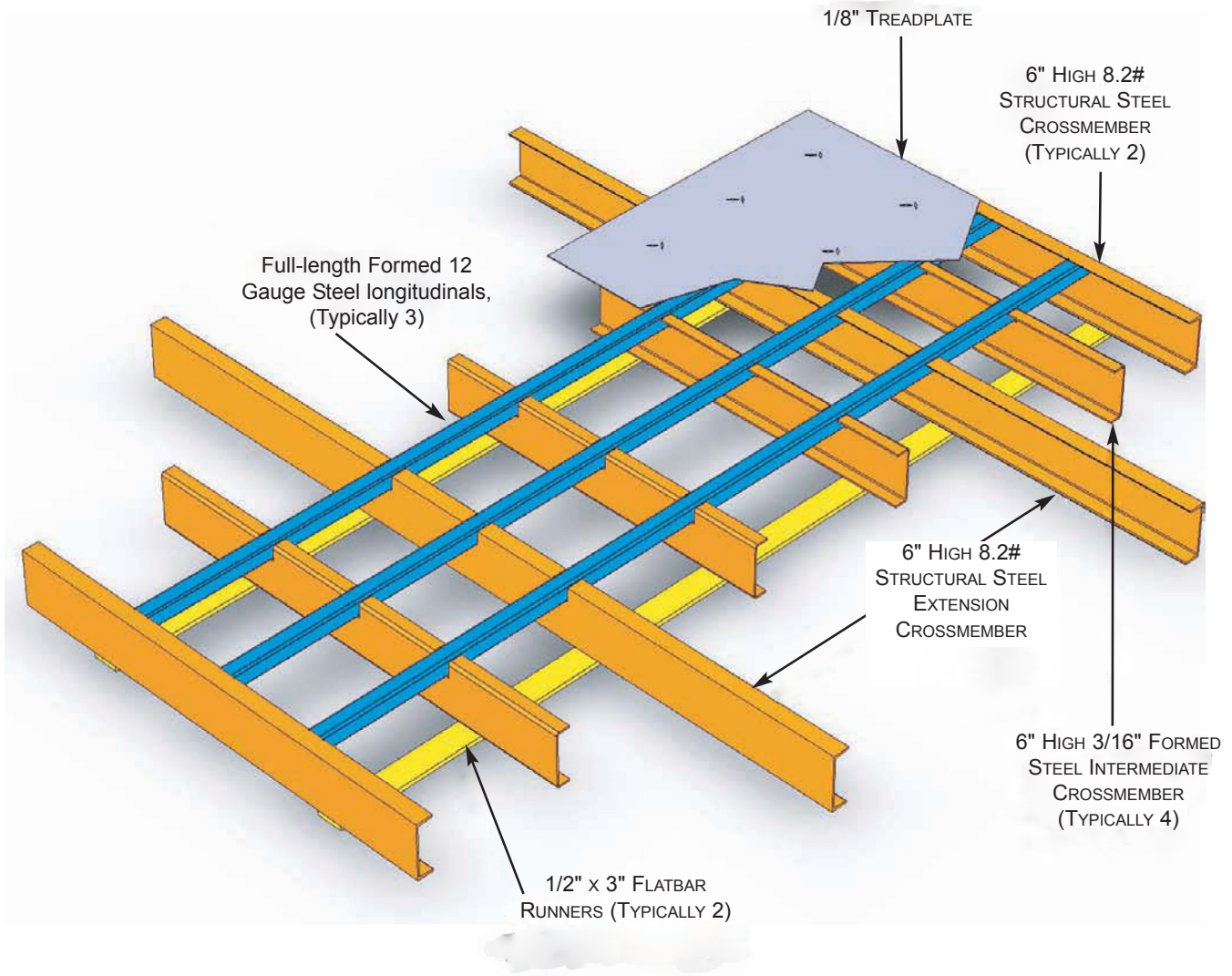

Understructure shown is for 60" CA and 108" floor length

Crossmembers are re-spaced or added as required to maintain structural integrity for longer floors

102" CA and 144" long floor has 4 additional intermediate crossmembers

108" CA and 156" long floor has 4 additional intermediate crossmembers

120" CA and 168" long floor has 4 additional intermediate crossmembers



## SERVICE BODY SPECIFICATION

### 60" CA or Larger

### Dual Rear Wheel – C-Series

#### Body Shell

- Compartment tops, compartment backs (load area walls) and bulkhead are constructed of 1/8" medium pattern treadplate steel.
- 12 gauge galvanized steel compartment fronts, rears and bottoms.
- Fenders, door facings and tailgate are constructed of 14 gauge A40 galvanized steel.
- One piece compartment top and back.
- 12 gauge treadplate overlay on tailgate.
- Die formed seamless fenders.

#### Floor

- 1/8" medium pattern treadplate floor.

#### Understructure

- 5" x 3" x 3/16" rectangular steel tubing front, rear and rear extension crossmembers.
- 5" high 3/16" formed intermediate crossmembers.
- 5" high 6.7# structural steel front extension crossmembers.
- 3 full-length formed 12 gauge steel "C" channel longitudinals.
- 1/2" x 3" steel flatbar long runners.
- Crane reinforced rear compartment for cranes up to 8,000# (50,000 ft. lbs.).

#### Doors

- Double panel doors with 14 gauge galvanized steel outer panel and 18 gauge corrugated inner panel.
- Door design includes a knife edge for continuous positive contact with the door seal.
- A full size, stainless steel paddle handle rotary latch is recessed into each door of the body.

#### Hinge Pins and Hinges

- Doors incorporate 5/16" diameter stainless steel rod hinge pins.
- Stainless steel pillow block hinges include self-lubricating plastic bushings.
- Hinge pillow blocks are attached to the body side with closed end pop rivets as standard. Body can be ordered with hinges welded as an option.

#### Door Retainers

- Spring loaded door retainers on vertical doors are easily detachable to allow the door to swing 180°.
- Heavy-duty chain supports on the horizontal doors are easily removable to allow the door to drop down.

#### Door Seals

- Automotive type square-bulb seal installs in a full perimeter protective channel. Seal is unbroken at the striker.

#### Shelving

- 4 full-height compartment partitions are furnished as standard. Half-height partitions are available as an option for all compartments except crane reinforced compartment.
- Shelving package is optional for C-Series bodies.

#### Tailgate

- 11-1/2" high.
- One-hand opening, slam close.
- Center release stainless steel latch.

#### Prime Paint

- All body components receive a five-stage state-of-the-art metal pretreatment and baked on primer.
- A second primer coating is applied after final body assembly for maximum corrosion resistance.

#### Undercoating

- Entire body underside is fully undercoated with an automotive grade undercoating.

#### Mounting Kit

- Litemount brackets for housing stop/tail/turn lights furnished as standard, ships loose. Lights not included.
- Mounting kit is optional on C-Series bodies.

#### Warranty

Lifetime Warranty applies to anything we have manufactured. Refer to written warranty page for details.

Revised 2/2022

In order to provide the most innovative and progressive equipment, all specifications and designs are subject to change without notice.

# Heavy-Duty Floor Understructure for C-Series Service Bodies

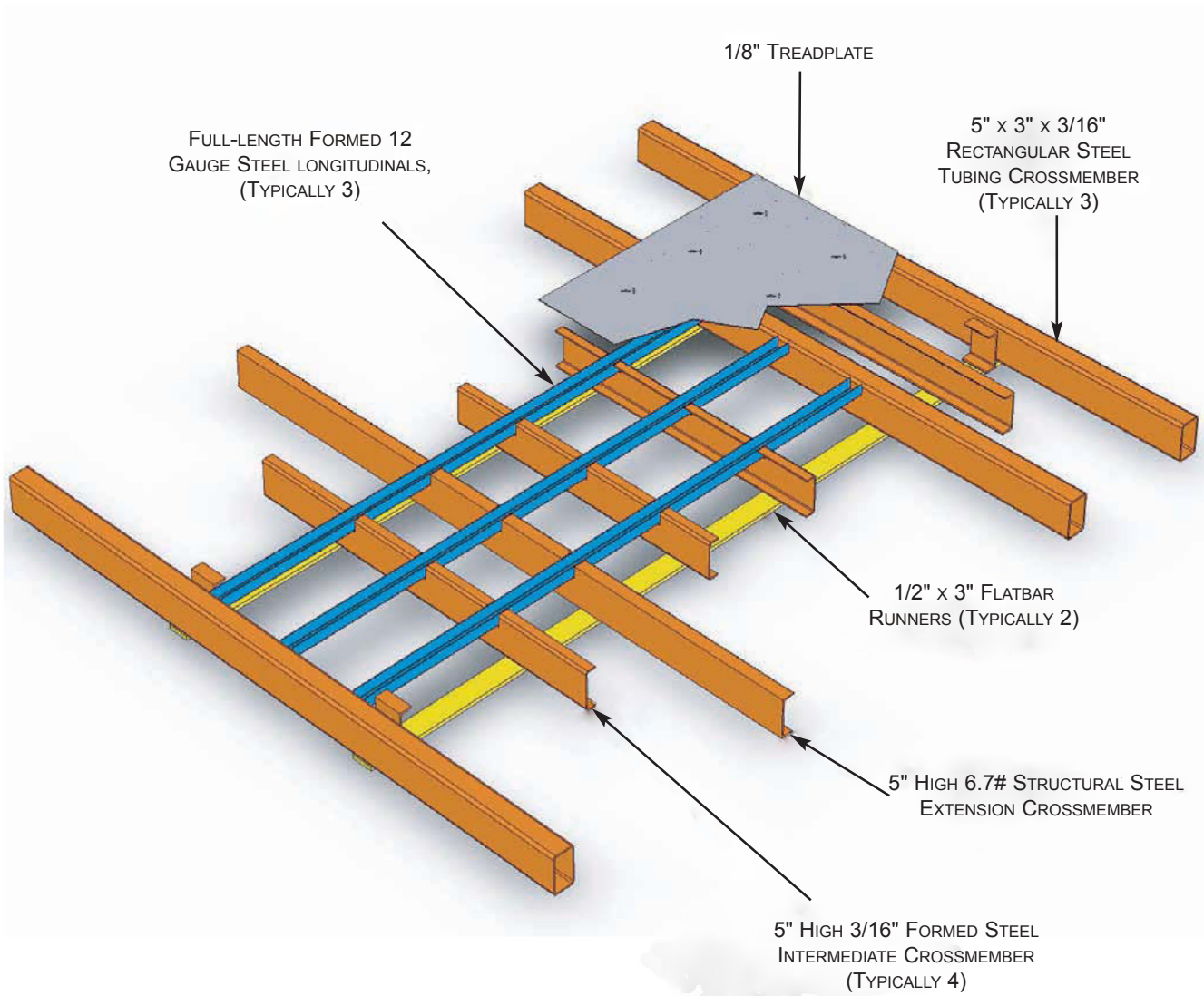

Understructure shown is for 60" CA and 108" floor length

Crossmembers are re-spaced or added as required to maintain structural integrity for longer floors

84" CA and 132" long floor has 1 additional intermediate crossmember  
108" CA and 156" long floor has 4 additional intermediate crossmembers  
120" CA and 168" long floor has 4 additional intermediate crossmembers



## SERVICE BODY SPECIFICATION 60" CA or Larger Dual Rear Wheel – CA-Series

### Body Shell

- Body sides, bulkhead, and tailgate are constructed of 14 gauge A40 galvanized steel.
- 12 gauge galvanized steel front and rear compartment panels.
- One piece compartment top and back. (Bodies up to 144" long.)
- 1/8" treadplate overlay on compartment tops, load area walls, front panel and tailgate.
- Die formed seamless fenders.

### Floor

- 1/8" medium pattern treadplate floor.

### Understructure

- 5" x 3" x 3/16" rectangular steel tubing front, rear and rear extension crossmembers.
- 5" high 3/16" formed intermediate crossmembers.
- 5" high 6.7# structural steel front extension crossmembers.
- 3 full-length 12 gauge formed steel "C" channel longitudinals.
- Crane reinforced rear compartment for cranes up to 8,000# (50,000 ft. lbs.).
- Understructure is further reinforced with 5" x 3" x 3/16" rectangular tubing subframe.

### Doors

- Double panel doors with 14 gauge galvanized steel outer panel and 18 gauge corrugated inner panel.
- Door design includes a knife edge for continuous positive contact with the door seal.
- A full size, stainless steel paddle handle rotary latch is recessed into each door of the body.

### Hinge Pins and Hinges

- Doors incorporate 5/16" diameter stainless steel rod hinge pins.
- Stainless steel pillow block hinges include self-lubricating plastic bushings.
- Hinge pillow blocks are attached to the body side with closed end pop rivets as standard. Body can be ordered with hinges welded as an option.

### Door Retainers

- Spring loaded door retainers on vertical doors are easily detachable to allow the door to swing 180°.

### Door Seals

- Automotive type square-bulb seal installs in a full perimeter protective channel. Seal is unbroken at the striker.

### Shelving

- 4 full-height compartment partitions are furnished as standard. Half-height partitions are available as an option for all compartments except crane reinforced compartment.
- Shelving package is optional on CA-Series bodies.

### Tailgate

- 11-1/2" high.
- One-hand opening, slam close.
- Center release stainless steel latch.

### Prime Paint

- All body components receive a five-stage state-of-the-art metal pretreatment and baked on primer.
- A second primer coating is applied after final body assembly for maximum corrosion resistance.

### Undercoating

- Entire body underside is fully undercoated with an automotive grade undercoating.

### Mounting Kit

- Litemount brackets for housing stop/tail/turn lights furnished as standard, ships loose. Lights not included.
- Mounting kit is optional on CA-Series bodies.

### Warranty

Lifetime Warranty applies to anything we have manufactured. Refer to written warranty page for details.

Revised 12/2021

In order to provide the most innovative and progressive equipment, all specifications and designs are subject to change without notice.



# Heavy-Duty Floor Understructure for CA-Series Service Bodies

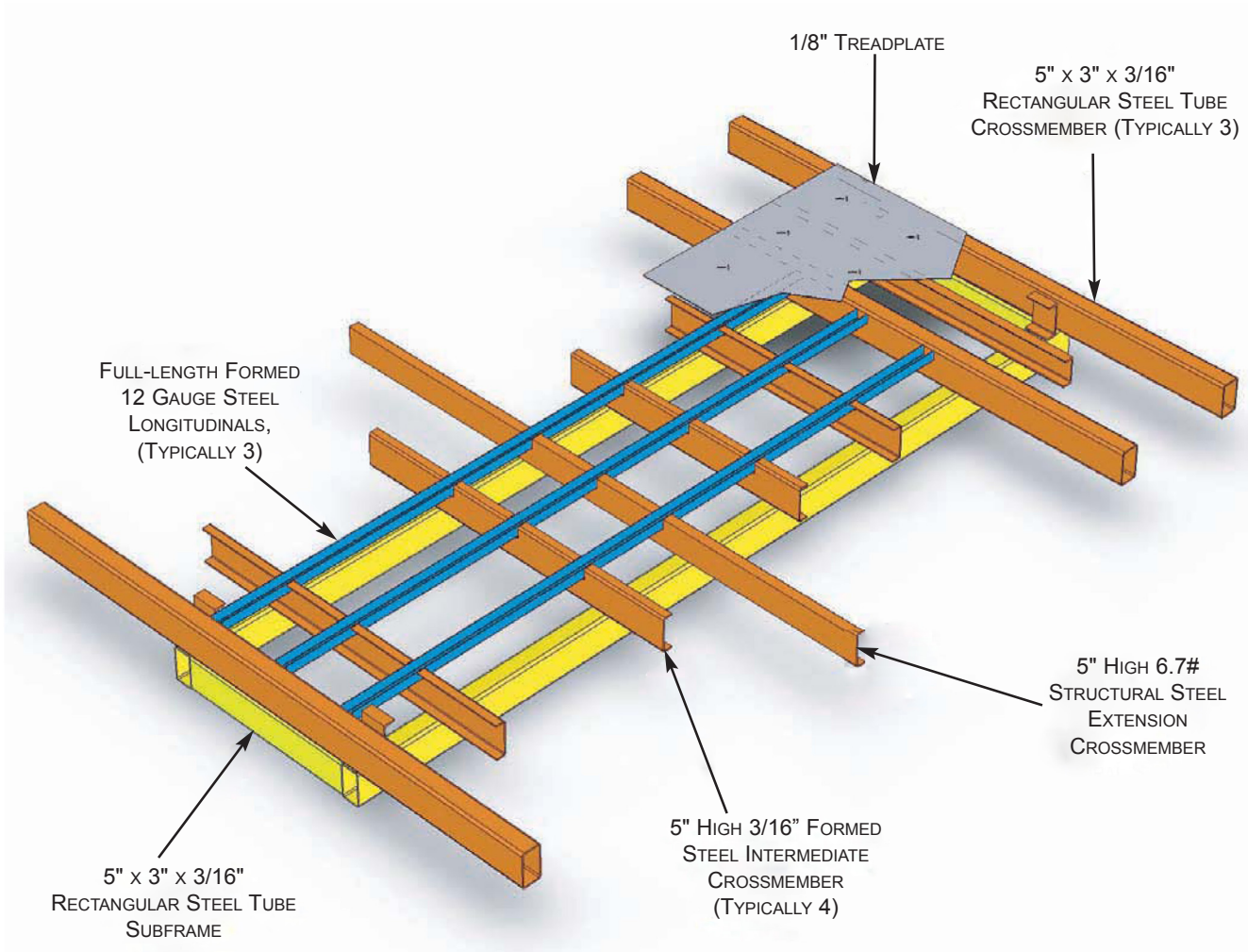

Understructure shown is for 84" CA and 132" floor length

Crossmembers are re-spaced or added as required to maintain structural integrity for longer floors

102" CA and 150" long floor has 2 additional intermediate crossmembers

108" CA and 156" long floor has 2 additional intermediate crossmembers

120" CA and 168" long floor has 3 additional intermediate crossmembers





## SERVICE BODY SPECIFICATION

### 60" CA or Larger

### Dual Rear Wheel – E-Series

#### Body Shell

- Body sides, bulkhead, and tailgate are constructed of 14 gauge A40 galvanized steel.
- One piece compartment top and back. (Bodies up to 144" long.)
- Die formed seamless fenders.

#### Floor

- 1/8" medium pattern treadplate floor with 3" longitudinal flange at each body side.

#### Understructure

- 4" high 5.4# structural steel front, rear and extension crossmembers.
- 4" high 10 gauge formed steel intermediate crossmembers.
- 3 full-length formed 12 gauge steel "C" channel longitudinals.
- 1/2" x 3" steel flatbar long runners.

#### Doors

- Double panel doors with 14 gauge galvanized steel outer panel and 18 gauge corrugated inner panel.
- Door design includes a knife edge for continuous positive contact with the door seal.
- A full size, stainless steel paddle handle rotary latch is recessed into each door of the body.

#### Rear Body Reinforcing Member

- 3/16" "hat" channel reinforcement across the rear of the body.

#### Hinge Pins and Hinges

- Doors incorporate 5/16" diameter stainless steel rod hinge pins.
- Stainless steel pillow block hinges include self-lubricating plastic bushings.
- Hinge pillow blocks are attached to the body side with closed end pop rivets as standard. Body can be ordered with hinges welded as an option.

#### Door Retainers

- Spring loaded door retainers on vertical doors are easily detachable to allow the door to swing 180°.
- Heavy-duty chain supports on the horizontal doors are easily removable to allow the door to drop down.

#### Door Seals

- Automotive type square-bulb seal installs in a full perimeter protective channel. Seal is unbroken at the striker.

#### Shelving

- Shelving and compartment partitions are removable allowing for the creation of various compartment interior arrangements.
- 4 full-height compartment partitions are furnished as standard. Half-height partitions are available as an option.
- Compartment shelving is adjustable on 2" centers.
- 16 gauge galvanized steel shelves are slotted for dividers on 2" centers.
- 20 fully folded dividers for compartment shelving.
- Material hook bar assembly with 3 hooks.

#### Tailgate

- 11-1/2" high.
- One-hand opening, slam close.
- Center release stainless steel latch.

#### Prime Paint

- All body components receive a five-stage state-of-the-art metal pretreatment and baked on primer.
- A second primer coating is applied after final body assembly for maximum corrosion resistance.

#### Undercoating

- Entire body underside is fully undercoated with an automotive grade undercoating.

#### Mounting Kit

- Mounting kit is optional on E-Series bodies.

#### Warranty

- Lifetime Warranty applies to anything we have manufactured. Refer to written warranty page for details.

Revised 12/2021

In order to provide the most innovative and progressive equipment, all specifications and designs are subject to change without notice.

# Heavy-Duty Floor Understructure for E-Series Service Bodies

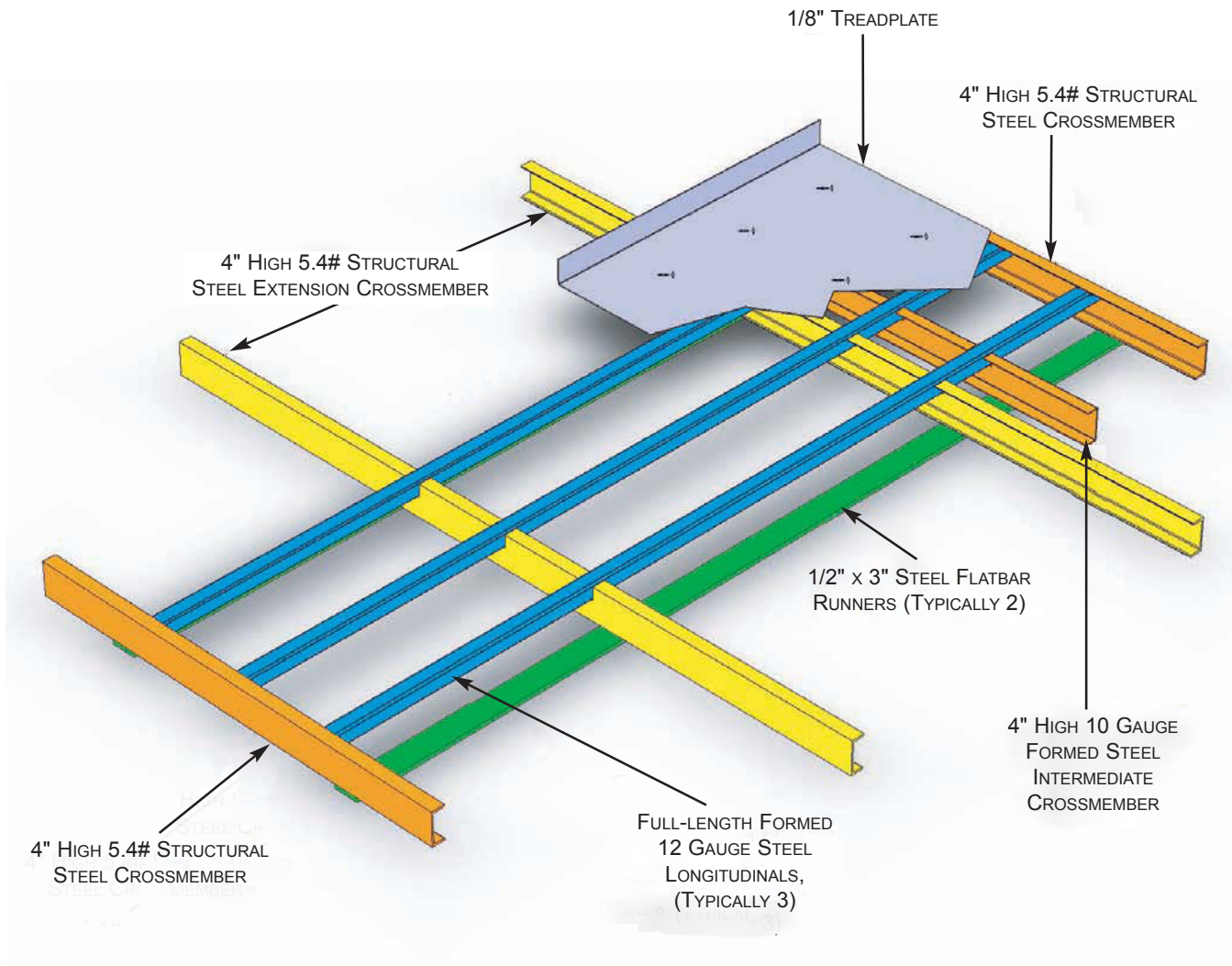

Understructure shown is for 60" CA and 108" floor length

Crossmembers are re-spaced or added as required to maintain structural integrity for longer floors

84" CA and 132" long floor has 2 additional intermediate crossmembers  
102" CA and 144" long floor has 5 additional intermediate crossmembers  
108" CA and 156" long floor has 6 additional intermediate crossmembers  
120" CA and 168" long floor has 7 additional intermediate crossmembers



## SERVICE BODY SPECIFICATION 60" CA or Larger Dual Rear Wheel – G-Series

### Body Shell

- Compartment tops, compartment backs (load area walls) and bulkhead are constructed of 12 gauge medium pattern treadplate steel.
- 12 gauge galvanized steel compartment fronts, rears and bottoms.
- Fenders, door facings and tailgate are constructed of 14 gauge A40 galvanized steel.
- One piece compartment top and back.
- 12 gauge treadplate overlay on tailgate.
- Die formed seamless fenders.

### Floor

- 1/8" medium pattern treadplate floor.

### Understructure

- 5" x 3" x 3/16" rectangular steel tubing front, rear and rear extension crossmembers.
- 5" high 3/16" formed intermediate crossmembers.
- 5" high 6.7# structural steel front extension crossmembers.
- 3 full-length formed 12 gauge steel "C" channel longitudinals.
- 1/2" steel flatbar long runners.
- Crane reinforced rear compartment for cranes up to 6,400# (40,000 ft. lbs.).

### Doors

- Double panel doors with 14 gauge galvanized steel outer panel and 18 gauge corrugated inner panel.
- Door design includes a knife edge for continuous positive contact with the door seal.
- A full size, stainless steel paddle handle rotary latch is recessed into each door of the body.

### Hinge Pins and Hinges

- Doors incorporate 5/16" diameter stainless steel rod hinge pins.
- Stainless steel pillow block hinges include self-lubricating plastic bushings.
- Hinge pillow blocks are attached to the body side with closed end pop rivets as standard. Body can be ordered with hinges welded as an option.

### Door Retainers

- Spring loaded door retainers on vertical doors are easily detachable to allow the door to swing 180°.
- Heavy-duty chain supports on the horizontal doors are easily removable to allow the door to drop down.

### Door Seals

- Automotive type square-bulb seal installs in a full perimeter protective channel. Seal is unbroken at the striker.

### Shelving

- 4 full-height compartment partitions are furnished as standard. Half-height partitions are available as an option for all compartments except crane reinforced compartment.
- Shelving package is optional on G-Series bodies.

### Tailgate

- 11-1/2" high.
- One-hand opening, slam close.
- Center release stainless steel latch.

### Prime Paint

- All body components receive a five-stage state-of-the-art metal pretreatment and baked on primer.
- A second primer coating is applied after final body assembly for maximum corrosion resistance.

### Undercoating

- Entire body underside is fully undercoated with an automotive grade undercoating.

### Mounting Kit

- Litemount brackets for housing stop/tail/turn lights furnished as standard, ships loose. Lights not included.
- Mounting kit is optional on G-Series bodies.

### Warranty

Lifetime Warranty applies to anything we have manufactured. Refer to written warranty page for details.

Revised 12/2021

In order to provide the most innovative and progressive equipment, all specifications and designs are subject to change without notice.

# Heavy-Duty Floor Understructure for G-Series Service Bodies

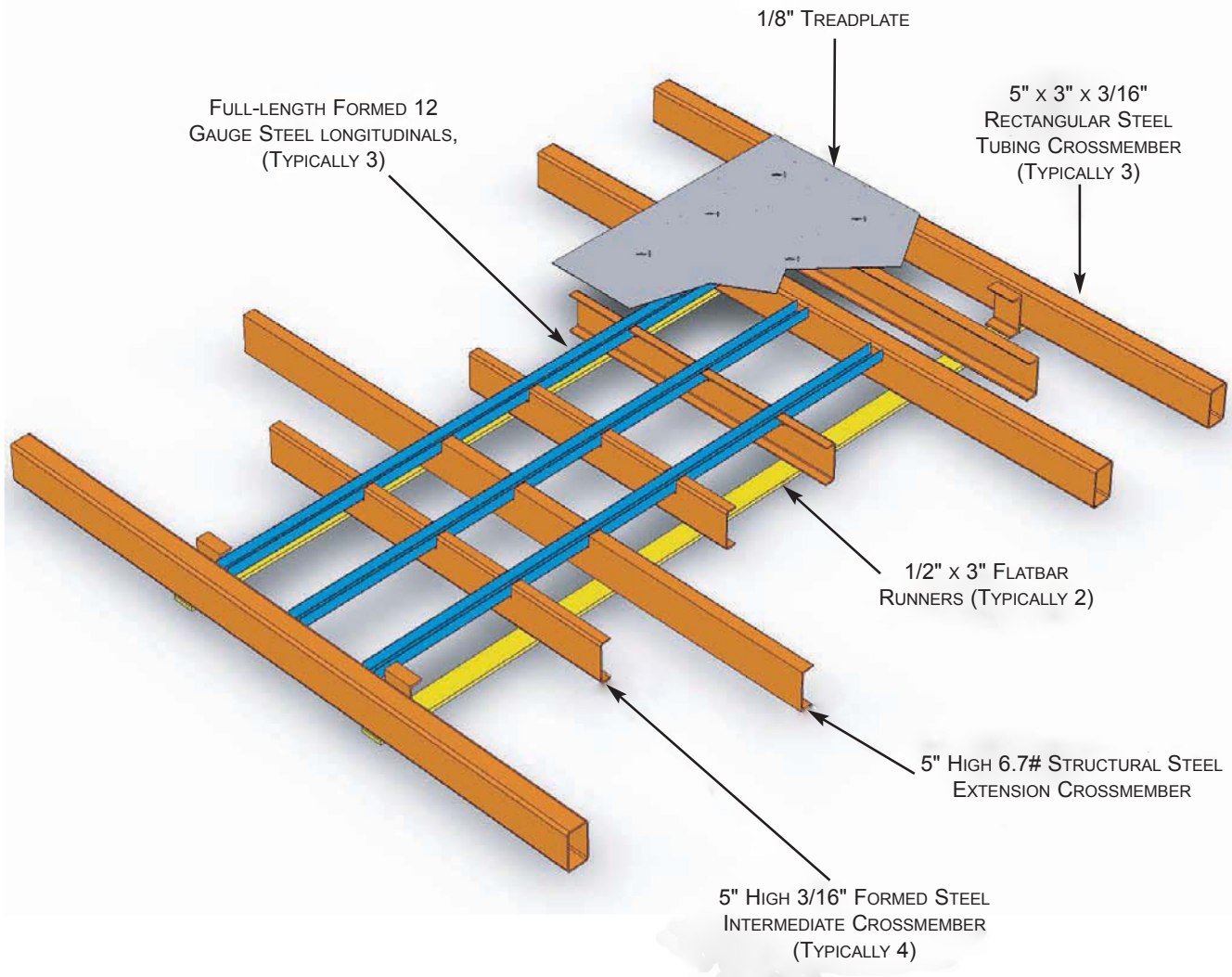

Understructure shown is for 60" CA and 108" floor length

Crossmembers are re-spaced or added as required to maintain structural integrity for longer floors

84" CA and 132" long floor has 1 additional intermediate crossmember