



BUILT TO WORK. BUILT TO LAST.

STEEL AND ALUMINUM TRUCK BEDS AND SERVICE BODIES

CM
TRUCK BEDS®

WWW.CMTRUCKBEDS.COM



BUILT TO WORK. BUILT TO LAST.

CM Truck Beds offers the industry's most rugged, durable and best-looking truck beds and service bodies. We're proud to be the product of choice for commercial fleets and work truck users. Whether you're looking for a steel flat bed, a specialty bed, a heavy-duty aluminum bed, or a versatile service body, CM Truck Beds has a product to meet your needs and exceed your expectations. Our diverse lineup will fit almost any cab and chassis or take-off body unit.



MOST OF OUR TRUCK BEDS AND SERVICE BODIES INCLUDE:

- Best-In-Class Rated B&W Trailer Hitches
- Premium TexArmor Powdercoat Finish (Steel Models)
- T-Handle Compression Toolbox Latches
- 3/8" Rubrail & Stake Pockets on many models
- Optronics LED Lighting with Lifetime Warranty
- Plug & Play Modular Sealed Wiring Harness
- 1/8" Steel Treadplate Decking
- 3" Steel Crossmembers
- Service Bodies Feature Component-Style Configuration
 - Easier to Customize, Maintain and Repair

With the best dealer inventory, exceptional lead times and industry-leading quality, count on CM Truck Beds as the platform for your success, now and long into the future.

THE DIFFERENCE IS CLEAR

OUR ENGINEERS WORK HARD TO ADAPT TO THE EVER-CHANGING STYLES OF OEM CHASSIS MANUFACTURERS, SO YOU'RE NOT JUST GETTING DURABILITY, BUT ALSO OPTIMUM USABILITY. QUITE SIMPLY, WE'RE COMMITTED TO PROVIDING A LEVEL OF QUALITY YOU CAN FEEL GREAT ABOUT, AT A VALUE THAT'S UNSURPASSED.

BEST-IN-CLASS RATED B&W HITCHES

While some manufacturers install hitches that are untested and carry rating loads untested, CM Truck Beds come standard with B&W hitches that are proven to withstand the heavy loads our beds tow. Each attachment point comes with quality electrical connections, ensuring that you tow with safety first.

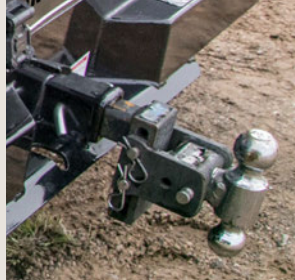

WARRANTY-PROTECTED LED LIGHTING

When safety counts, count on CM Truck Beds. We utilize the safest, easiest-to-maintain lights on the market. LED lights are brighter, light up instantaneously, make for easier maintenance, and come with a standard lifetime warranty from Optronics.



RECESSED TOOLBOXES W/T HANDLE COMPRESSION LATCHES

When you care about your tools, CM Truck Beds' recessed toolbox doors are the only solution that ensures maximized cargo protection. Our doors recess into the box, creating a seal while our T Handle compression latches pull the door into the box when closed.

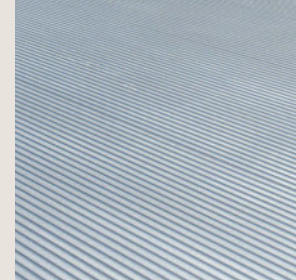

EXTRUDED ALUMINUM FLOORS (ALUMINUM MODELS)

How's this for tough: Our extruded aluminum floors have a weight rating of 600 pounds per square foot. Some say aluminum is weaker; we say they're just doing it wrong. (Not standard on AL ER Models.)



SINGLE-PIECE SQUARE TUBE HEADACHE RACKS

Clearly the toughest, heaviest square tube headache racks in the business. You won't see breaks, cuts or pieced-together parts in our racks; built from a single piece, they're indestructible. When the unexpected occurs, count on our headache racks to keep you safe.



3-PIECE PLUG & PLAY MODULAR SEALED WIRING HARNESS

We understand that our beds are exposed to harsh conditions that oftentimes cause wiring to corrode, pull apart or deteriorate. CM Truck Beds wiring harnesses are designed for durability in even the most challenging conditions.



SS

The sleek SS comes equipped with a best-in-class tubular steel headache rack, smooth side rails, and a solid one-piece rear skirt.

FEATURES AND OPTIONS

LENGTHS	84", 8'6", 9'4", 11'4"
HEADACHE RACK	Steel Tube
HEADACHE RACK LIGHTING	Clear LED Oval
DECK	1/8" Treadplate
FRAME RAILS	4" Structural Channel Steel
CROSSMEMBERS	3" Roll-Formed 3/16" Channel Crossmembers
REAR SKIRT	Solid One Piece with Tapered Corners
GN HITCH	30K lb. B&W Hitch with Welded Ball
BP HITCH	24K lb. 2 1/2" B&W Hitch with Receiver Tube
SIDE RAILS	Integrated Side Rails with Internal Stake Pockets

FUEL FILL	Angled
12V TRAILER PLUG	Round 7 Pin in GN Box, Round 7 Pin/4 Way Flat on Rear
REAR LIGHTING	Clear LED Oval
LIGHT BOX (REAR SKIRT)	Steel
MARKER LIGHTING	Bullet DOT Approved LED
TOOLBOX	Optional Underbody
TOOLBOX HANDLE	N/A
FENDERS	N/A
SIDESTEPS	N/A
TIE DOWNS	N/A

NOTABLE OPTIONS INCLUDE: 3/16" Heavy-Duty Deck; 30K B&W Hitch with Turnover Ball (required for 5th Wheel capability); Cargo Light; Drop-In or Fold-Down Side Rails; Gooseneck Trough; Rubber or Blackwood Flooring; Underbody Toolbox



STEEL AND ALUMINUM TRUCK BEDS



RD / ALRO

ALUMINUM

Tough enough to haul the big loads, the popular RD models are expertly designed, professional-grade workhorses that are sized to fit almost any unit.

	STEEL	ALUMINUM
LENGTHS	84", 8'6", 9'4", 11'4"	84", 8'6", 9'4", 11'4"
HEADACHE RACK	Steel Tube	Aluminum Tube
HEADACHE RACK LIGHTING	Clear LED Oval	Clear LED Oval
DECK	1/8" Treadplate	Extruded Aluminum Floor
FRAME RAILS	4" Structural Channel Steel	4" Structural Channel Steel
CROSSMEMBERS	3" Roll-Formed 3/16" Channel Crossmembers	3" x 3" 3/16" Square Tube Crossmembers
REAR SKIRT	Solid One Piece with Tapered Corners	Solid One Piece with Tapered Corners
GN HITCH	30K lb. B&W Hitch with Welded Ball	30K lb. B&W Hitch with Welded Ball
BP HITCH	24K lb. 2 1/2" B&W Hitch with Receiver Tube	24K lb. 2 1/2" B&W Hitch with Receiver Tube
SIDE RAILS	3/8" x 2" Side Rails with Stake Pockets	3/8" x 2" Side Rails with Stake Pockets
FUEL FILL	Angled	Angled (Cast Aluminum)
12V TRAILER PLUG	Round 7 Pin in GN Box, Round 7 Pin/4 Way Flat on Rear	Round 7 Pin in GN Box, Round 7 Pin/4 Way Flat on Rear
REAR LIGHTING	Clear LED Oval	Clear LED Oval
LIGHT BOX (REAR SKIRT)	Steel	Aluminum
MARKER LIGHTING	Bullet DOT Approved LED	Bullet DOT Approved LED
TOOLBOX	Optional Underbody	Optional Underbody
TOOLBOX HANDLE	N/A	N/A
FENDERS	N/A	N/A
SIDESTEPS	N/A	N/A
TIE DOWNS	N/A	N/A

FEATURES AND OPTIONS



NOTABLE OPTIONS INCLUDE: 3/16" Heavy-Duty Deck; 30K B&W Hitch with Turnover Ball (required for 5th Wheel capability); Cargo Light; Drop-In or Fold-Down Side Rails; Gooseneck Trough; Wood, Rumber or Blackwood Flooring; Underbody Toolbox; Aluminum Underbody Toolboxes (AL RO model)

SK / ALASKA

ALUMINUM

Top-notch features and hardware on the SK models include a best-in-class tubular headache rack, LED lighting, top-rated B&W hitches, and integrated toolboxes.



FEATURES AND OPTIONS

	STEEL	ALUMINUM
LENGTHS	84", 8'6", 9'4", 11'4"	84", 8'6", 9'4", 11'4"
HEADACHE RACK	Steel Tube	Aluminum Tube
HEADACHE RACK LIGHTING	Clear LED Oval	Clear LED Oval
DECK	1/8" Treadplate	Extruded Aluminum Floor
FRAME RAILS	4" Structural Channel Steel	4" Structural Channel Steel
CROSSMEMBERS	3" Roll-Formed 3/16" Channel Crossmembers	3" x 3" 3/16" Square Tube Crossmembers
REAR SKIRT	Solid One Piece with Rear Step	Solid One Piece with Rear Step
GN HITCH	30K lb. B&W Hitch with Welded Ball	30K lb. B&W Hitch with Welded Ball
BP HITCH	24K lb. 2 1/2" B&W Hitch with Receiver Tube	24K lb. 2 1/2" B&W Hitch with Receiver Tube
SIDE RAILS	3/8" x 2" Side Rails with Stake Pockets	3/8" x 2" Side Rails with Stake Pockets
FUEL FILL	Angled	Angled (Cast Aluminum)
12V TRAILER PLUG	Round 7 Pin in GN Box, Round 7 Pin/4 Way Flat on Rear	Round 7 Pin in GN Box, Round 7 Pin/4 Way Flat on Rear
REAR LIGHTING	Clear LED Oval	Clear LED Oval
LIGHT BOX (REAR SKIRT)	Steel	Aluminum
MARKER LIGHTING	Bullet DOT Approved LED	Bullet DOT Approved LED
TOOLBOX	(4) Standard Integrated	(4) Standard Integrated
TOOLBOX HANDLE	Chrome T Handle Compression	Chrome T Handle Compression
FENDERS	Steel Radius	Aluminum Radius
SIDESTEPS	In Front of and Behind Fender	Aluminum Steps In Front of and Behind Fender
TIE DOWNS	N/A	N/A

NOTABLE OPTIONS INCLUDE: 3/16" Heavy-Duty Deck; Steel SK Deluxe can have Flush Mount B&W 30K lb Turnover Ball; Color Primer Only (SK model); Dovetail Deck; Drop-In or Fold-Down Side Rails; Gooseneck Trough; Rear Rubrail; Stainless Fenders (SK model); Wood, Rubber or Blackwood Flooring



STEEL AND ALUMINUM TRUCK BEDS



ER / ALER

ALUMINUM

For impressive durability, great functionality and eye-catching design with zero tradeoffs, the stylish ER models are the smart choice for your hauling needs.

	STEEL	ALUMINUM
LENGTHS	84", 8'6", 9'4", 11'4"	84", 8'6", 9'4", 11'4"
HEADACHE RACK	Steel Tube	Aluminum Tube
HEADACHE RACK LIGHTING	Clear LED Oval w/Chrome Housing	Clear LED Oval w/Chrome Housing
DECK	1/8" Treadplate	1/8" Aluminum Treadplate
FRAME RAILS	4" Structural Channel Steel	4" Structural Channel Steel
CROSSMEMBERS	3" Roll-Formed 3/16" Channel Crossmembers	3"x 3" 3/16" Square Tube Crossmembers
REAR SKIRT	Solid One Piece with Rear Step	Solid One Piece with Rear Step
GN HITCH	30K lb. B&W Hitch with Welded Ball in Trough	30K lb. B&W Hitch with Welded Ball in Trough
BP HITCH	24K lb. 2 1/2" B&W Hitch with Receiver Tube	24K lb. 2 1/2" B&W Hitch with Receiver Tube
SIDE RAILS	Raised Side Rail with Aluminum Cap	Raised Side Rail with Aluminum Cap
FUEL FILL	Angled (Cast Aluminum)	Angled (Cast Aluminum)
12V TRAILER PLUG	Round 7 Pin in GN Box, Round 7 Pin/4 Way Flat on Rear	Round 7 Pin in GN Box, Round 7 Pin/4 Way Flat on Rear
REAR LIGHTING	Clear LED Oval with Chrome Housing	Clear LED Oval with Chrome Housing
LIGHT BOX (REAR SKIRT)	Cast Aluminum	Cast Aluminum
MARKER LIGHTING	Bullet DOT Approved LED	Bullet DOT Approved LED
TOOLBOX	(4) Standard Integrated	(4) Standard Integrated
TOOLBOX HANDLE	Chrome T Handle Compression	Chrome T Handle Compression
FENDERS	Chrome Radius	Chrome Radius
SIDESTEPS	In Front of and Behind Fender	Aluminum Steps In Front of and Behind Fender
TIE DOWNS	(4) 18" Airline Track Tiedowns (4) Attachment Ring	(4) 18" Airline Track Tiedowns (4) Attachment Ring

FEATURES AND OPTIONS



NOTABLE OPTIONS INCLUDE: 3/16" Heavy-Duty Deck; 30K B&W Hitch with Turnover Ball (required for 5th Wheel capability); Bale Spikes (ER model); Cargo Lights; Color Primer Only (ER model)



TM

The TM is America's ultimate Towing-Style utility body, with smart, ready-to-work features including a full-width tailgate and full-length shovel box.

Photo shows optional work lights

FEATURES AND OPTIONS

LENGTHS	84", 8'6", 9'4", 11'4"
HEADACHE RACK	Steel Tube
HEADACHE RACK LIGHTING	Clear LED Oval
DECK	1/8" Treadplate
FRAME RAILS	4" Structural Channel Steel
CROSSMEMBERS	3" Roll-Formed 3/16" Channel Crossmembers
REAR SKIRT	Solid One Piece with Rear Step
GN HITCH	30K lb. B&W Hitch with Welded Ball
BP HITCH	24K lb. 2 1/2" B&W Hitch with Receiver Tube
SIDE RAILS	N/A

FUEL FILL	Angled
12V TRAILER PLUG	Round 7 Pin in GN Box, Round 7 Pin/4 Way Flat on Rear
REAR LIGHTING	Clear LED Oval
LIGHT BOX (REAR SKIRT)	Steel
MARKER LIGHTING	Bullet DOT Approved LED
TOOLBOX	Utility Box in Front, Top-Open 3/4 Length Shovel Box; Low-Profile Chain Box in Rear
TOOLBOX HANDLE	Chrome T Handle Compression
FENDERS	Steel Welded-In
SIDESTEPS	In front of and behind fender
TIE DOWNS	(4) 18" Airline Track Tiedowns, (4) Attachment Rings

NOTABLE TM OPTIONS INCLUDE: 3/16" Heavy-Duty Deck; 30K B&W Hitch with Turnover Ball (flush mount only); Bale Spikes; Color Primer Only; Stainless Fenders; Work Lights (pictured)



STEEL AND ALUMINUM TRUCK BEDS



TM / TMX

DELUXE

The TM Deluxe is designed to haul trailers from bumper or gooseneck positions and features an opossum belly, work lights and a tall rear toolbox. And with its 48"-wide deck, the TMX is the best solution for single-wheel chassis.

	TM DELUXE	TMX
LENGTHS	84", 8'6", 9'4", 11'4"	84", 8'6", 9'4", 11'4"
HEADACHE RACK	Steel Tube	Steel Tube
HEADACHE RACK LIGHTING	Clear LED Oval	Clear LED Oval
DECK	1/8" Treadplate	1/8" Treadplate
FRAME RAILS	4" Structural Channel Steel	4" Structural Channel Steel
CROSSMEMBERS	3" Roll-Formed 3/16" Channel Crossmembers	3" Roll-Formed 3/16" Channel Crossmembers
REAR SKIRT	Solid One Piece with Rear Step	Solid One Piece with Rear Step
GN HITCH	30K lb. B&W Hitch with Welded Ball	30K lb. B&W Hitch with Welded Ball
BP HITCH	24K lb. 2 1/2" B&W Hitch with Receiver Tube	24K lb. 2 1/2" B&W Hitch with Receiver Tube
SIDE RAILS	N/A	N/A
FUEL FILL	Angled	Angled
12V TRAILER PLUG	Round 7 Pin in GN Box, Round 7 Pin/4 Way Flat on Rear	Round 7 Pin in GN Box, Round 7 Pin/4 Way Flat on Rear
REAR LIGHTING	Clear LED Oval	Clear LED Oval
LIGHT BOX (REAR SKIRT)	Steel	Steel
MARKER LIGHTING	Bullet DOT Approved LED	Bullet DOT Approved LED
TOOLBOX	Utility Box in front; Top-Open 1/2 Length Shovel Box; Tall Chain Box in rear; Opossum Belly	Utility Box in front; Top-Open 3/4 Length Shovel Box; Low-Profile Chain Box in Rear
TOOLBOX HANDLE	Chrome T Handle Compression	Chrome T Handle Compression
FENDERS	Steel Radius	Steel Radius
SIDESTEPS	In front of and behind fender	In front of and behind fender
TIE DOWNS	(4) 18" Airline Track Tiedowns, (4) Attachment Rings	(4) 18" Airline Track Tiedowns, (4) Attachment Rings

FEATURES AND OPTIONS



TMX Single Wheel Model

NOTABLE OPTIONS INCLUDE: 3/16" Heavy-Duty Deck; 30K B&W Hitch with Turnover Ball (flush mount only); Bale Spikes; Color Primer Only; Stainless Fenders; Work Lights (standard on TM Deluxe)



ALTM

ALUMINUM

Maximized storage and payload capacity are two of the many reasons that you will want to try our aluminum tradesman body. When you realize our storage and towing ratings, you will quickly see why the ALTM is the premiere choice for hard work.

LENGTHS	8'6", 9'4", 11'4"
HEADACHE RACK	Aluminum Tube
HEADACHE RACK LIGHTING	Clear LED Oval
DECK	Extruded Aluminum
FRAME RAILS	4" Structural Channel Steel
CROSSMEMBERS	3"x 3" 3/16" Square Tube Crossmembers
REAR SKIRT	Solid One Piece with Rear Step
GN HITCH	30K lb. B&W Hitch with Welded Ball in Recessed Box
BP HITCH	24K lb. 2 1/2" B&W Hitch with Receiver Tube
SIDE RAILS	N/A

FUEL FILL	Angled
12V TRAILER PLUG	Round 7 Pin in GN Box, Round 7 Pin/4 Way Flat on Rear
REAR LIGHTING	Clear LED Oval
LIGHT BOX (REAR SKIRT)	Aluminum
MARKER LIGHTING	Bullet DOT Approved LED
TOOLBOX	Utility Box in Front, Top-Open 3/4 Length Shovel Box; Low-Profile Chain Box in Rear
TOOLBOX HANDLE	Chrome T Handle Compression
FENDERS	Aluminum
SIDESTEPS	In front of and behind fender
TIE DOWNS	(4) 18" Airline Track Tiedowns, (4) Attachment Rings

FEATURES AND OPTIONS

NOTABLE OPTIONS INCLUDE: Cargo Light



ALRS

ALUMINUM

Light on price, heavy on performance: The all-aluminum ALRS truck bed delivers maximized fuel economy, payload and corrosion resistance at an incredible value.

FEATURES AND OPTIONS

LENGTHS	84", 8'6", 9'4"
HEADACHE RACK	Aluminum Tube
HEADACHE RACK LIGHTING	Clear LED Oval
DECK	Extruded Aluminum Floor
FRAME RAILS	4" Aluminum Channel
CROSSMEMBERS	3" Extruded Aluminum Crossmembers
REAR SKIRT	14" Solid One Piece Square Back
GN HITCH	N/A
BP HITCH	N/A
SIDE RAILS	3/8 x 2" Aluminum Extrusion with Aluminum Stake Pockets

FUEL FILL	Angled (Cast Aluminum)
12V TRAILER PLUG	N/A
REAR LIGHTING	Clear LED Oval
LIGHT BOX (REAR SKIRT)	Aluminum
MARKER LIGHTING	Bullet DOT Approved LED
TOOLBOX	Optional Underbody
TOOLBOX HANDLE	N/A
FENDERS	N/A
SIDESTEPS	N/A
TIE DOWNS	N/A

NOTABLE OPTIONS INCLUDE: Cargo Light; Underbody Toolbox; Wood, Rubber or Blackwood Flooring



PL PLS

The PL and PLS models are platform bodies with an edge, featuring the strongest, most durable materials on the market with best-in-class features to get the job done.



FEATURES AND OPTIONS

	PL	PLS
LENGTHS	9'-18" = Standard Duty 12'-24" = Heavy Duty	9'-18'
CAB PROTECTOR	Formed Bulkhead with Punched Window Cutout	Bolt-On Headache Rack and Ship-Through Corners
CAB PROTECTOR LIGHTING	N/A	N/A
DECK	9'-18" = 1/8" Treadplate 12'-24" = 3/16" Treadplate	1/8" Treadplate
FRAME RAILS	9'-18" = 4" Structural Channel Steel 12'-24" = 8" Channel Steel	4" Structural Channel Steel
CROSSMEMBERS	9'-18" = 3" Roll Formed Channel Steel on 12" Centers 12'-24" = 4" Channel Steel on 12" Centers	3" Roll formed 3/16" Channel Steel
REAR SKIRT	One Piece Steel	One Piece Steel
GN HITCH	N/A	N/A
BP HITCH	ICC Optional	ICC Optional
SIDE RAILS	3/8" x 2" Side Rails with Stake Pockets	Smooth Sides w/ Internal Stake Pockets
FUEL FILL	N/A	N/A
12V TRAILER PLUG	N/A	N/A
REAR LIGHTING	N/A	N/A
LIGHT BOX (REAR SKIRT)	N/A	N/A
MARKER LIGHTING	Bullet DOT Approved LED	Bullet DOT Approved LED
TOOLBOX	Optional Underbody	Optional Underbody
TOOLBOX HANDLE	N/A	N/A
FENDERS	N/A	N/A
SIDESTEPS	N/A	N/A

NOTABLE OPTIONS INCLUDE: 3/16" Heavy-Duty Deck; 30K B&W Hitch with Turnover Ball (required for 5th Wheel capability); Bale Spikes, Cargo Light; Color Primer Only; Front Underbody Toolbox; Stake Sides; Wood, Rumber or Blackwood Flooring



STEEL AND ALUMINUM TRUCK BEDS



ALPL
ALUMINUM

Take uncertainty out of the equation with CM's AL PL model: Strong and durable yet lightweight and efficient, this aluminum platform body is reliable through-and-through.

LENGTHS	12'-18' = Standard Duty
CAB PROTECTOR	Formed Bulkhead with Punched Window Cutout
CAB PROTECTOR LIGHTING	N/A
DECK	Extruded Aluminum Floor
FRAME RAILS	4" Aluminum Channel
CROSSMEMBERS	3" Aluminum Channel Crossmembers
REAR SKIRT	One Piece Aluminum
GN HITCH	N/A
BP HITCH	ICC Optional
SIDE RAILS	3/8" x 2" Side Rails with Stake Pockets

FUEL FILL	N/A
12V TRAILER PLUG	N/A
REAR LIGHTING	N/A
LIGHT BOX (REAR SKIRT)	N/A
MARKER LIGHTING	Bullet DOT Approved LED
TOOLBOX	Optional Underbody
TOOLBOX HANDLE	N/A
FENDERS	N/A
SIDESTEPS	N/A
TIE DOWNS	N/A

FEATURES AND OPTIONS

NOTABLE OPTIONS INCLUDE: Aluminum Underbody Toolboxes; Wood, Rubber or Blackwood Flooring



DB

With its sleek design, ultra-durable hardware and unsurpassed features, including a heavy-duty two-way rear gate, this rugged dump hauling body is the smart choice for professionals in construction, excavation, landscaping and beyond.

FEATURES AND OPTIONS

LENGTHS	9', 11'
CAB PROTECTOR	Formed Steel with Cab Protector
CAB PROTECTOR LIGHTING	N/A
DECK	10-Gauge
FRAME RAILS	6" Structural Channel Steel
CROSSMEMBERS	3" Structural Crossmembers
REAR SKIRT	N/A
GN HITCH	N/A
BP HITCH	Optional ICC Rear Bumper
SIDE RAILS	N/A

FUEL FILL	Chassis OEM
12V TRAILER PLUG	Completed at Upfit
REAR LIGHTING	Chassis OEM
LIGHT BOX (REAR SKIRT)	N/A
MARKER LIGHTING	Red
TOOLBOX	N/A
TOOLBOX HANDLE	N/A
FENDERS	N/A
SIDESTEPS	N/A
TIE DOWNS	(4) Welded with D-Rings

NOTABLE OPTIONS INCLUDE: Fold-Down Sides; Tarp



STEEL AND ALUMINUM TRUCK BEDS



GP

Unique and versatile by design, the GP model thrives on the oilfield; its Gin Pole lifting system makes quick work of loading and unloading equipment.

LENGTHS	8'6", 9'4", 11'4"
HEADACHE RACK	Steel Pipe
HEADACHE RACK LIGHTING	N/A
DECK	3/16" Treadplate
FRAME RAILS	6" Structural Channel Steel
CROSSMEMBERS	3" Roll-Formed 3/16" Channel Crossmembers
REAR SKIRT	Solid One Piece Square Tailboard with Rolling Section & 5" Rolling Tailboard
GN HITCH	24K lb. Hitch with Welded Ball
BP HITCH	18.5K lb. Hitch with Receiver Tube
SIDE RAILS	Integrated Side Rails with Internal Stake Pockets

FUEL FILL	Angled
12V TRAILER PLUG	Round 7 Pin in GN Box, Round 7 Pin/4 Way Flat on Rear
REAR LIGHTING	LED Oval
LIGHT BOX (REAR SKIRT)	Steel
MARKER LIGHTING	Bullet DOT Approved LED
TOOLBOX	(2) Standard in Front of Fenders
TOOLBOX HANDLE	T Handle Compression
FENDERS	N/A
PAINT FINISH	Premium Polyurethane
POLES	Schedule 80 Gin Poles with Frame and Pipe Holders

FEATURES AND OPTIONS

NOTABLE OPTIONS INCLUDE: Junk Basket; Water Cooler Rack; Winch Package (12K or 15K)



SZ

Load and unload hay from the comfort of your cab with the SZ's best-in-class dual hydraulic lifting cylinders and 4-directional remote control, plus dual round bale capacity.

FEATURES AND OPTIONS

LENGTHS	8'6", 9'4", 11'4"
HEADACHE RACK	Steel Tube
HEADACHE RACK LIGHTING	Clear LED Oval
DECK	1/8" Treadplate
FRAME RAILS	6" Structural Channel Steel
CROSSMEMBERS	3" Roll formed 3/16" Channel Crossmembers
REAR SKIRT	Solid One Piece with Rear Step
GN HITCH	30K lb. B&W Hitch with Welded Ball
BP HITCH	24K lb. 2 1/2" B&W Hitch with Receiver Tube
SIDE RAILS	Tube

FUEL FILL	Angled
12V TRAILER PLUG	Round 7 Pin in GN Box, Round 7 Pin/4 Way Flat on Rear
REAR LIGHTING	Clear LED Oval
LIGHT BOX (REAR SKIRT)	Steel
MARKER LIGHTING	Bullet DOT Approved LED
TOOLBOX	(2) Standard in Front of Fender
TOOLBOX HANDLE	Black T Handle Compression
FENDERS	N/A
SIDESTEPS	N/A
TIE DOWNS	(4) 18" Airline Track Tiedowns, (4) Attachmnt Rings

NOTABLE OPTIONS INCLUDE: 3/16" Heavy-Duty Deck; 30K B&W Hitch with Turnover Ball (required for 5th Wheel capability); Cargo Light



STEEL AND ALUMINUM TRUCK BEDS



BL

Heavy-duty integrated bale spikes transport huge loads securely, while top-quality steel construction ensures lasting durability. The BL (Bale Spike) is available as an option on any steel CM Truck Beds model.

LENGTHS	8'6", 9'4", 11'4"
HEADACHE RACK	Steel Tube
HEADACHE RACK LIGHTING	Clear LED Oval
DECK	1/8" Treadplate
FRAME RAILS	4" Structural Channel Steel
CROSSMEMBERS	3" Roll-Formed 3/16" Channel Crossmembers
REAR SKIRT	Solid One Piece with Rear Step
GN HITCH	30K lb. B&W Hitch with Welded Ball
BP HITCH	24K lb. 2 1/2" B&W Hitch with Receiver Tube
SIDE RAILS	3/8" Rubrail with Stake Pockets

FUEL FILL	Angled
12V TRAILER PLUG	Round 7 Pin in GN Box, Round 7 Pin/4 Way Flat on Rear
REAR LIGHTING	Clear LED Oval
LIGHT BOX (REAR SKIRT)	Steel
MARKER LIGHTING	Bullet DOT Approved LED
TOOLBOX	One Standard in Front on R/S
TOOLBOX HANDLE	Chrome T Handle Compression
FENDERS	Steel Radius
SIDESTEPS	N/A

FEATURES AND OPTIONS

NOTABLE OPTIONS INCLUDE: 3/16" Heavy-Duty Deck; 30K B&W Hitch with Turnover Ball (required for 5th Wheel capability); Cargo Light; Drop-In Side Rails



CT CONTRACTOR BODY

Hard work and efficiency go hand in hand when you use our contractor body to transport your hard work to the job site. This body features a best-in-class material rack and fold down aluminum stake side rails for maximized cargo and access.

FEATURES AND OPTIONS

LENGTHS	9'4", 11'4"
HEADACHE RACK	Steel Tube
HEADACHE RACK LIGHTING	Clear LED Oval
DECK	1/8" Treadplate
FRAME RAILS	4" Structural Channel Steel
CROSSMEMBERS	3" Roll-Formed 3/16" Channel Crossmembers
REAR SKIRT	Solid One Piece with Rear Step
GN HITCH	N/A
BP HITCH	24K lb. 2 1/2" B&W Hitch with Receiver Tube
SIDE RAILS	3/8" x 2" Side Rails with Stake Pockets

FUEL FILL	Angled
12V TRAILER PLUG	Round 7 Pin/4 Way Flat on Rear
REAR LIGHTING	Clear LED Oval
LIGHT BOX (REAR SKIRT)	Steel
MARKER LIGHTING	Bullet DOT Approved LED
TOOLBOX	(4) Standard Toolboxes
TOOLBOX HANDLE	Black T Handle Compression
MATERIAL RACK	2,000 lb. Square Tube with Swinging Crossmember
SIDE RAILS	Aluminum Fold Down Side Rails

NOTABLE OPTIONS INCLUDE: 3/16" Heavy-Duty Deck; Cargo Light



STEEL AND ALUMINUM TRUCK BEDS

STEEL



MODEL	SS	RD	SK	ER	TM	TM DELUXE	TMX	PL	PLS	CT
LENGTHS	84", 8'6", 9'4", 11'4"	84", 8'6", 9'4", 11'4"	84", 8'6", 9'4", 11'4"	84", 8'6", 9'4", 11'4"	84", 8'6", 9'4", 11'4"	84", 8'6", 9'4", 11'4"	84", 8'6", 9'4", 11'4"	9'-18" = Standard Duty, 12'-24" = Heavy Duty	9'-18"	9'4", 11'4"
HEADACHE RACK	Steel Tube	Steel Tube	Steel Tube	Steel Tube	Steel Tube	Steel Tube	Steel Tube	Formed Bulkhead with Punched Window Cutout	Bolt-On Headache Rack and Ship-Through Corners	Steel Tube
HEADACHE RACK LIGHTING	Clear LED Oval	Clear LED Oval	Clear LED Oval	Clear LED Oval w/ Chrome Housing	Clear LED Oval	Clear LED Oval	Clear LED Oval	N/A	N/A	Clear LED Oval
DECK	1/8" Treadplate	1/8" Treadplate	1/8" Treadplate	1/8" Treadplate	1/8" Treadplate	1/8" Treadplate	1/8" Treadplate	9'-18" = 1/8" Treadplate, 12'-24" = 3/16" Treadplate	1/8" Treadplate	1/8" Treadplate
FRAME RAILS	4" Structural Channel Steel	4" Structural Channel Steel	4" Structural Channel Steel	4" Structural Channel Steel	4" Structural Channel Steel	4" Structural Channel Steel	4" Structural Channel Steel	9'-18" = 4" Structural Channel Steel, 12'-24" = 8" Channel	4" Structural Channel Steel	4" Structural Channel Steel
CROSSMEMBERS	3" Roll-Formed 3/16" Channel Crossmembers	3" Roll-Formed 3/16" Channel Crossmembers	3" Roll-Formed 3/16" Channel Crossmembers	3" Roll-Formed 3/16" Channel Crossmembers	3" Roll-Formed 3/16" Channel Crossmembers	3" Roll-Formed 3/16" Channel Crossmembers	3" Roll-Formed 3/16" Channel Crossmember	9'-18" = 3" Roll-Formed Channel Steel on 12" Centers, 12'-24" = 4" Channel on 12" Centers	3" Roll-Formed 3/16" Channel Crossmember	3" Roll-Formed 3/16" Channel Crossmember
REAR SKIRT	Solid One Piece with Tapered Corners	Solid One Piece with Tapered Corners	Solid One Piece with Tapered Corners and Rear Step	Solid One Piece with Tapered Corners and Rear Step	Solid One Piece with Tapered Corners and Rear Step	Solid One Piece with Tapered Corners and Rear Step	Solid One Piece with Tapered Corners and Rear Step	One Piece Steel	One Piece Steel	Solid One Piece with Tapered Corners and Rear Step
GN HITCH	30K lb. B&W Hitch w/ Welded Ball in Recessed Box	30K lb. B&W Hitch w/ Welded Ball in Recessed Box	30K lb. B&W Hitch w/ Welded Ball in Recessed Box	30K lb. B&W Hitch with Welded Ball in Trough	30K lb. B&W Hitch w/ Welded Ball in Recessed Box	30K lb. B&W Hitch w/ Welded Ball in Recessed Box	30K lb. B&W Hitch w/ Welded Ball in Recessed Box	N/A	N/A	N/A
BP HITCH	24K lb. 2 1/2" B&W Hitch with Receiver Tube	24K lb. 2 1/2" B&W Hitch with Receiver Tube	24K lb. 2 1/2" B&W Hitch with Receiver Tube	24K lb. 2 1/2" B&W Hitch with Receiver Tube	24K lb. 2 1/2" B&W Hitch with Receiver Tube	24K lb. 2 1/2" B&W Hitch with Receiver Tube	24K lb. 2 1/2" B&W Hitch with Receiver Tube	ICC optional	ICC Optional	24K lb. 2 1/2" B&W Hitch with Receiver Tube
SIDE RAILS	Integrated Side Rails with Internal Stake Pockets	3/8" x 2" Side Rails with Stake Pockets	3/8" x 2" Side Rails with Stake Pockets	Raised Side Rail with Aluminum Cap	N/A	N/A	N/A	3/8" x 2" Side Rails with Stake Pockets	Smooth Side Rails with Internal Stake Pockets	3/8" x 2" Side Rails with Stake Pockets
FUEL FILL	Angled	Angled	Angled	Angled (Cast Aluminum)	Angled	Angled	Angled	N/A	N/A	Angled
12V TRAILER PLUG	Round 7 Pin in GN Box, Round 7 Pin/4 Way Flat on Rear	Round 7 Pin in GN Box, Round 7 Pin/4 Way Flat on Rear	Round 7 Pin in GN Box, Round 7 Pin/4 Way Flat on Rear	Round 7 Pin in GN Box, Round 7 Pin/4 Way Flat on Rear	Round 7 Pin in GN Box, Round 7 Pin/4 Way Flat on Rear	Round 7 Pin in GN Box, Round 7 Pin/4 Way Flat on Rear	Round 7 Pin GN Box, Round 7 Pin/4 Way Flat on Rear	N/A	N/A	Round 7 Pin/4 Way Flat on Rear
REAR LIGHTING	Clear LED Oval	Clear LED Oval	Clear LED Oval	Clear LED Oval w/ Chrome housing	Clear LED Oval	Clear LED Oval	Clear LED Oval	N/A	N/A	Clear LED Oval
LIGHT BOX (REAR SKIRT)	Steel	Steel	Steel	Cast Aluminum	Steel	Steel	Steel	N/A	N/A	In Rear Skirt-Steel
MARKER LIGHTING	Bullet DOT Approved LED	Bullet DOT Approved LED	Bullet DOT Approved LED	Bullet DOT Approved LED	Bullet DOT Approved LED	Bullet DOT Approved LED	Bullet DOT Approved LED	Bullet DOT Approved LED	Bullet DOT Approved LED	Bullet DOT Approved LED
TOOLBOX	Optional Underbody	Optional Underbody	(4) Standard Integrated	(4) Standard Integrated	Utility Box in Front, Top-Open 3/4 Length Shovel Box, Low-Profile Chain Box in rear	Utility Box in front; Top-Open 1/2 Length Shovel Box, Tall Chain Box in rear; Opposum Belly	Utility Box in front; Top-Open 3/4 Length Shovel Box; Low-Profile Chain Box in rear	Optional Underbody	Optional Underbody	(4) Standard Toolboxes
TOOLBOX HANDLE	N/A	N/A	Chrome T Handle Compression	Chrome T Handle Compression	Chrome T Handle Compression	Chrome T Handle Compression	Chrome T Handle Compression	N/A	N/A	Chrome T Handle Compression
FENDERS	N/A	N/A	Steel Radius	Chrome Radius	Steel Welded-In	Steel Radius	Steel Radius	N/A	N/A	N/A
SIDE STEPS	N/A	N/A	In Front of and Behind Fender	In Front of and Behind Fender	In Front of and Behind Fender	In Front of and Behind Fender	In Front of and Behind Fender	N/A	N/A	N/A
TIE DOWNS	N/A	N/A	N/A	(4) 18" Airline Track Tiedowns (4) Attachment Rings	(4) 18" Airline Track Tiedowns (4) Attachment Rings	(4) 24" Airline Track Tiedowns (4) Attachment Rings	(4) 24" Airline Track Tiedowns, (4) Attachment Rings	N/A	N/A	N/A
ADDITIONAL FEATURES	Drop-in Side Rails Optional	Drop-in Side Rails Optional	Drop-in Side Rails Optional	Trough in Center for Convenient Hookup	Rear Tailgate with Paddle Latch; Rear Work Lights	Rear Tailgate with Paddle Latch; Rear Work Lights	Rear Tailgate with Paddle Latch; Rear Work Lights	Optional HD Package Optional ICC Bumper	Optional ICC Bumper	Aluminum Fold Down Sides; Material Rack

ALUMINUM

MODEL	DB	GP	SZ	BL	AL RD	AL SK	AL ER	AL TM	AL PL ALL ALUMINUM	AL RS ALL ALUMINUM
LENGTHS	9', 11'	84", 8'6", 9'4", 11'4"	8'6", 9'4", 11'4"	8'6", 9'4", 11'4"	84", 8'6", 9'4", 11'4"	84", 8'6", 9'4", 11'4"	84", 8'6", 9'4", 11'4"	8'6", 9'4", 11'4"	12'-18"= Standard Duty	84", 8'6", 9'4"
HEADACHE RACK	Formed Steel with Cab Protector	Steel Pipe	Steel Tube	Steel Tube	Aluminum Tube	Aluminum Tube	Aluminum Tube	Aluminum Tube	Formed Bulkhead with Punched Window Cutout	Aluminum Tube
HEADACHE RACK LIGHTING	N/A	N/A	Clear LED Oval	Clear LED Oval	Clear LED Oval	Clear LED Oval	Clear LED Oval w/ Chrome Housing	Clear LED Oval	N/A	Clear LED Oval
DECK	10-Gauge	3/16" Treadplate	1/8" Treadplate	1/8" Treadplate	Extruded Aluminum Floor	Extruded Aluminum Floor	1/8" Aluminum Treadplate	Extruded Aluminum Floor	Extruded Aluminum Floor	Extruded Aluminum Floor
FRAME RAILS	6" Structural Channel Steel	6" Structural Channel Steel	6" Structural Channel Steel	4" Structural Channel Steel	4" Structural Channel Steel	4" Structural Channel Steel	4" Structural Channel Steel	4" Structural Channel Steel	4" Aluminum Channel	4" Aluminum Channel
CROSSMEMBERS	3" Structural Channel	3" Roll-Formed 3/16" Channel Crossmembers	3" Roll-Formed 3/16" Channel Crossmember	3" Roll-Formed 3/16" Channel Crossmember	3" x 3" 3/16" Square Tube Crossmembers	3" x 3" 3/16" Square Tube Crossmembers	3" x 3" 3/16" Square Tube Crossmembers	3" x 3" 3/16" Square Tube Crossmembers	3" Aluminum Channel Crossmembers	3" Extruded Aluminum Crossmembers
REAR SKIRT	N/A	Solid One Piece with Square Tailboard at Rear & 5" Rolling Tailboard	Solid One Piece with Rear Step	Solid One Piece with Rear Step	Solid One Piece with Tapered Corners	Solid One Piece with Rear Step	Solid One Piece with Rear Step	Solid One Piece with Rear Step	One Piece Aluminum	14" Solid One Piece Square Back
GN HITCH	N/A	24K lb. Hitch with Welded Ball	30K lb. B&W Hitch with Welded Ball	30K lb. B&W Hitch with Welded Ball	30K lb. B&W Hitch with Welded Ball in Recessed Box	30K lb. B&W Hitch with Welded Ball in Recessed Box	30K lb. B&W Hitch with Welded Ball in Trough	30K lb. B&W Hitch with Welded Ball in Recessed Box	N/A	N/A
BP HITCH	Optional ICC Rear Bumper	18.5K lb Hitch with Receiver Tube	24K lb. 2 1/2" B&W Hitch with Receiver Tube	24K lb. B&W Hitch with Receiver Tube	24K lb. 2 1/2" B&W Hitch with Receiver Tube	24K lb. 2 1/2" B&W Hitch with Receiver Tube	24K lb. 2 1/2" B&W Hitch with Receiver Tube	24K lb. 2 1/2" B&W Hitch with Receiver Tube	ICC Optional	N/A
SIDE RAILS	N/A	Integrated Side Rails with Internal Stake Pockets	Tube	3/8" Rubrail with Stake Pockets	3/8" X 2" Side Rails with Stake Pockets	3/8" X 2" Side Rails with Stake Pockets	Raised Side Rail with Aluminum Cap	N/A	3/8" X 2" Side Rails with Stake Pockets	3/8" X 2" Aluminum Extrusion with Aluminum Stake Pockets
FUEL FILL	Chassis OEM	Angled	Angled	Angled	Angled (Cast Aluminum)	Angled (Cast Aluminum)	Angled (Cast Aluminum)	Angled (Cast Aluminum)	N/A	Angled (Cast Aluminum)
12V TRAILER PLUG	Completed at Upfit	Round 7 Pin in GN Box, Round 7 Pin/4 Way Flat on Rear	Round 7 Pin in GN Box, Round 7 Pin/4 Way Flat on Rear	Round 7 Pin in GN Box, Round 7 Pin/4 Way Flat on Rear	Round 7 Pin in GN Box, Round 7 Pin/4 Way Flat on Rear	Round 7 Pin in GN Box, Round 7 Pin/4 Way Flat on Rear	Round 7 Pin in GN Box, Round 7 Pin/4 Way Flat on Rear	Round 7 Pin in GN Box, Round 7 Pin/4 Way Flat on Rear	N/A	N/A
REAR LIGHTING	Chassis OEM	LED Oval	Clear LED Oval	Clear LED Oval	Clear LED Oval	Clear LED Oval	Clear LED Oval w/Chrome Housing	Clear LED Oval	N/A	Clear LED Oval
LIGHT BOX(REAR SKIRT)	N/A	Steel	Steel	Steel	Aluminum	Aluminum	Cast Aluminum	Aluminum	N/A	Aluminum
MARKER LIGHTING	Red	Bullet DOT Approved LED	Bullet DOT Approved LED	Bullet DOT Approved LED	Bullet DOT Approved LED	Bullet DOT Approved LED	Bullet DOT Approved LED	Bullet DOT Approved LED	Bullet DOT Approved LED	Bullet DOT Approved LED
TOOLBOX	N/A	(2) Standard in Front of Fenders	(2) Standard in Front of Fenders	(1) Standard in Front on R/S	Optional Underbody	(4) Standard Integrated	(4) Standard Integrated	Utility Box in Front, Top-Open 3/4 Length Shovel Box; Low-Profile Chain Box in Rear	Optional Underbody	Optional Underbody
TOOLBOX HANDLE	N/A	Chrome T Handle Compression	Chrome T Handle Compression	Chrome T Handle Compression	N/A	Chrome T Handle Compression	Chrome T Handle Compression	Chrome T Handle Compression	N/A	N/A
FENDERS	N/A	N/A	N/A	Steel Radius	N/A	Aluminum Radius	Chrome Radius	Aluminum Radius	N/A	N/A
SIDE STEPS	N/A	N/A	N/A	N/A	N/A	Aluminum Steps in Front of and Behind Fender	Aluminum Steps in Front of and Behind Fender	Aluminum Steps in Front of and Behind Fender	N/A	N/A
TIE DOWNS	(4) Welded in D-Rings	N/A	(4) 18" Airline Track Tiedowns, (4) Attachment Rings	N/A	N/A	N/A	(4) 18" Airline Track Tiedowns (2) Attachment Rings	(4) 18" Airline Track Tiedowns (4) Attachment Rings	N/A	N/A
ADDITIONAL FEATURES	Bolt-on Hoist Subframe and Install Kit Rigid or Fold-Down Sides	(2) Schedule 80 Gin Poles with Troughs on Both Sides, Optional Rolling Tailboard on Rear			Drop-In Aluminum Side Rails (Optional)	Drop-In Aluminum Side Rails (Optional)	Trough In Center For Convenient Hookup	Rear Tailgate with Paddle Latch	Optional ICC Bumper, Aluminum Stake Sides	Drop-In Aluminum Side Rails (Optional)

VERSATILITY FOR EVERY BODY

CM TRUCK BEDS SERVICE BODIES ARE THE MOST VERSATILE ON THE MARKET TODAY. WHATEVER THE APPLICATION, CM HAS THE RIGHT SERVICE BODY AVAILABLE AND READY TO BE DELIVERED FASTER THAN ANY BODY. COMPONENT-STYLE CONFIGURATIONS ALLOW FOR EASY CUSTOMIZATION, AND THE BEST WARRANTY IN THE INDUSTRY ENSURES YEARS OF RELIABLE USE.

COMPONENT-STYLE CONFIGURATION

Go ahead, put our products through the wringer. Unlike many in the industry, our component bodies are bolted together, which makes repair and maintenance far easier. Need a different configuration? Customization is as simple as unbolting the part you want to change.



DURABLE POWDERCOAT FINISH

While other companies stick to paint, CM Truck Beds coats every Service Body we make with powder. Using the highest quality powdercoat finish, we go under every edge and cover every crevice to ensure your service body is protected. This superior finish also adds a shine that will last for many years.

GAS CYLINDER DOOR SHOCKS

We don't use simple springs, we use the finest gas shocks on the market today. Even when your hands are full, our gas shocks allow you to easily open and close our doors.



HEAVY-DUTY REAR TAILGATES

All Service Bodies from CM Truck Beds feature tailgates that are tough enough to keep materials inside the deck where they belong. Need to step to get in a bed? No problem: These tailgates are rated at over 400 pounds, supporting even the largest operators to gain access.



DECKS

Our best-in-class steel decks provide a solid foundation for ensuring our bodies will live up to the rigorous expectations of our customers. We not only start with a strong deck, but also coat it with our super-durable Black Lava deck coating, which enhances the overall performance of our Service Bodies.



CB

COMPONENT BODY

CM Truck Beds' CB model is America's ultimate utility Service Body. Often copied, the CB is unparalleled in quality, with long-lasting hardware and remarkable durability.

4 YEAR
48,000 MILE
WARRANTY
CM
TRUCK BEDS

6 YEARS
NO RUST THROUGH
GUARANTEE

FEATURES AND OPTIONS

LENGTHS	76", 81", 82", 98", 110", 134"
HEADACHE RACK	Optional
HEADACHE RACK LIGHTING	N/A
DECK	12 Gauge Galvanneal Steel with Black Lava Coating
FRAME RAILS	Bed Delete - 12 Gauge, Cab Chassis - 10 Gauge
CROSSMEMBERS	Bed Delete - 12 Gauge, Cab Chassis - 10 Gauge
GN HITCH	N/A
BP HITCH	Optional Bolt-on (Cab Chassis)

FUEL FILL	Angled Cast
REAR LIGHTING	Clear LED Oval
MARKER LIGHTING	Bullet DOT Approved LED
TOOLBOX	6 Standard Integrated Toolboxes
TOOLBOX HANDLE	Chrome T Handle Compression
FENDERS	Polished Aluminum Trim
TIEDOWNS	(4) Tiedown Loops

NOTABLE OPTIONS INCLUDE: Fliptop Sidepack Compartments; Masterlock; Material Rack; Headache Rack;



SERVICE BODIES



CBA

COMPONENT BODY

CM Truck Beds' CB model is America's ultimate utility hauling Service Body. Often copied, the CB is unparalleled in quality, with long-lasting hardware and remarkable durability.

4 YEAR
48,000 MILE
WARRANTY
CM
TRUCK BEDS

**10 YEARS
NO CORROSION
GUARANTEE**

LENGTHS	76", 81", 82", 98", 110", 134"
HEADACHE RACK	Optional
HEADACHE RACK LIGHTING	N/A
DECK	3/16" Aluminum Deck with Black Lava Coating
FRAME RAILS	3/16" Aluminum
CROSSMEMBERS	3/16" Aluminum
GN HITCH	N/A
BP HITCH	Optional Bolt-On (Cab Chasis)

FUEL FILL	Angled Cast
REAR LIGHTING	Clear LED Oval
MARKER LIGHTING	Bullet DOT Approved LED
TOOLBOX	6 Standard Integrated Toolboxes
TOOLBOX HANDLE	Chrome T Handle Compression
FENDERS	Polished Aluminum Trim
TIEDOWNS	(4) Tiedown Loops

FEATURES AND OPTIONS

NOTABLE OPTIONS INCLUDE: Fliptop Sidepack Compartments; Masterlock; Material Rack; Headache Rack;



4 YEAR
48,000 MILE
WARRANTY
CM
TRUCK BEDS

6 YEARS
NO RUST THROUGH
GUARANTEE

STEEL WELDED SERVICE BODY **SB**

CM's welded aluminum service body maximizes payload and resists the corrosion that most commercial customers want to prevent in their work trucks. Our wide variety of options allows our fleet and commercial customers to have a body that fits their needs.

FEATURES AND OPTIONS

LENGTHS	76", 81", 82", 98", 110", 134"
HEADACHE RACK	Optional
HEADACHE RACK LIGHTING	N/A
DECK	.125" Treaplate Steel Deck
FRAME RAILS	Bed Delete - 12 Gauge, Cab Chassis - 10 Gauge
CROSSMEMBERS	Bed Delete - 12 Gauge, Cab Chassis - 10 Gauge
GN HITCH	N/A
BP HITCH	Optional Bolt-on (Cab Chassis)

FUEL FILL	Angled Cast
REAR LIGHTING	Clear LED Oval
MARKER LIGHTING	Bullet DOT Approved LED
TOOLBOX	6 Standard Integrated Toolboxes
TOOLBOX HANDLE	Chrome T Handle Compression
FENDERS	Polished Aluminum Trim
TIEDOWNS	(4) Tiedown Loops

NOTABLE OPTIONS INCLUDE: Fliptop Sidepack Compartments; Masterlock; Material Rack; Headache Rack;



SERVICE BODIES



4 YEAR
48,000 MILE
WARRANTY
CM
TRUCKS

10 YEARS
NO CORROSION
GUARANTEE

SBA

ALUMINUM WELDED SERVICE BODY
CM's welded aluminum service body maximizes payload and resists the corrosion that most commercial customers want to prevent in their work trucks. Our wide variety of options allows our fleet and commercial customers to have a body that fits their needs.

LENGTHS	76", 81", 82", 98", 110" 134"
HEADACHE RACK	Optional
HEADACHE RACK LIGHTING	N/A
DECK	.125" Treaplate Aluminum Deck
FRAME RAILS	3/16" Aluminum
CROSSMEMBERS	3/16" Aluminum
GN HITCH	N/A
BP HITCH	Optional Bolt-on (Cab Chassis)

FUEL FILL	Angled Cast
REAR LIGHTING	Clear LED Oval
MARKER LIGHTING	Bullet DOT Approved LED
TOOLBOX	6 Standard Integrated Toolboxes
TOOLBOX HANDLE	Chrome T Handle Compression
FENDERS	Polished Aluminum Trim
TIEDOWNS	(4) Tiedown Loops

FEATURES AND OPTIONS

NOTABLE OPTIONS INCLUDE: Fliptop Sidepack Compartments; Masterlock; Material Rack; Headache Rack;



BRANDED STAINLESS STEEL T HANDLE COMPRESSION LATCHES

Not only do we have the best toolbox doors in the industry, we help you seal them with a two step compression latch that ensures you can work with confidence that your tools will not be exposed to the elements.



OPTIONAL B&W HITCHES

At CM, we are committed to towing safety, that's why we have designed our hitches in conjunction with B&W Trailer Hitches to ensure that your trailers are towed safely with higher capacities than any other service body on the market. We know that our customers demand high tow ratings, so we have a solution that will meet the needs of our commercial customers.

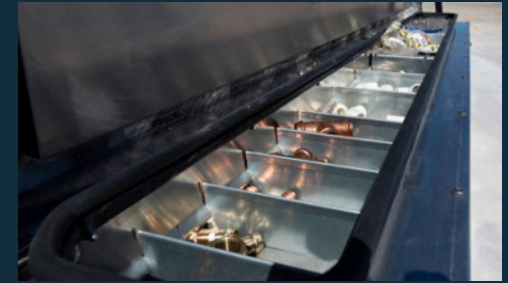

OPTIONAL FLIP-TOP SIDE PACK COMPARTMENTS

At CM Truck Beds, we know that our customers like to be organized. With that in mind, we have designed a better solution to organization, easy to add aftermarket and made out of aluminum so that they will not corrode like most service bodies on the market today.

BEST IN CLASS FEATURES



THREE PIECE DOORS WITH D-BULB WEATHER-STRIPPING

Toolboxes carry a worker's best friend: his tools. To protect them, our toolbox doors feature heavy-duty T-handle compression latches, and are sealed with automotive D-bulb weather-stripping to ensure that no moisture gains entry. So your tools are not only safe, but also safely out of the elements.



LED REAR LIGHTING WITH WIRING HARNESS

When safety counts, count on CM Truck Beds to take care of you. We utilize the safest, easiest-to-maintain lights available. LED lights are brighter, light up instantaneously, and make for easier maintenance.

4-YEAR /48,000-MILE WARRANTY

Some companies say they stand behind their products; we put it in writing. While the industry standard is to only warranty a body for a period of 36 months, we're happy to go above and beyond and offer a 48-month warranty. We recognize what an investment a Service Body can be and we want you to know that we're with you for the long haul.



CR STEEL CRANE BODY

Designed for your everyday field service truck and ready to be upfit in a fraction of the time. Get great storage capacity and lifting capabilities with our electric Tiger Crane solutions.

LENGTHS	108", 132"
BODY	A60 Galvanneal Steel
HEADACHE RACK	Optional
DECK	Heavy Duty 3/16" Smooth Steel
FRAME RAILS	Torsion Box
TAIL SHELF	72" x 12" x 18" Work Bench with Passthrough Storage
BP HITCH	24K lb. 2 1/2" B&W Hitch with Receiver Tube
MASTER LOCKS	Spring Loaded Pistol Grip Compartment Locks

FUEL FILL	Angled with Standard Dual Fender Cutouts
12V TRAILER PLUG	Round 7 Pin/4 Way Flat on Rear
REAR LIGHTING	Oval LED Lights in Light Boxes
MARKER LIGHTING	Bullet DOT Approved .75" LED Lights
SIDEPACKS	44"x 22" Boxes on L and R with Optional Raised Curbside Comp.
COMPARTMENT LATCHES	Chrome T Handle Compression with 3-Point Latch
FENDERS	Rubber Fender Trim with Optional Aluminum Trim
SIDESTEPS	Standard Punched Treadsteps on each end of Tailshelf
TIE DOWNS	(6) 2,000 lb. Recessed D-Ring Tiedowns in Deck Area

FEATURES AND OPTIONS

NOTABLE OPTIONS INCLUDE: Optional Customizable CARR Sidesteps under Compartments; Remote Control T Handle Compression E-Lock Latches

SERVICE BODY CONFIGURATIONS

- With an array of sizes and configurations to choose from, there's a CM Truck Beds Service Body designed to meet the specific needs of your industry and your fleet.

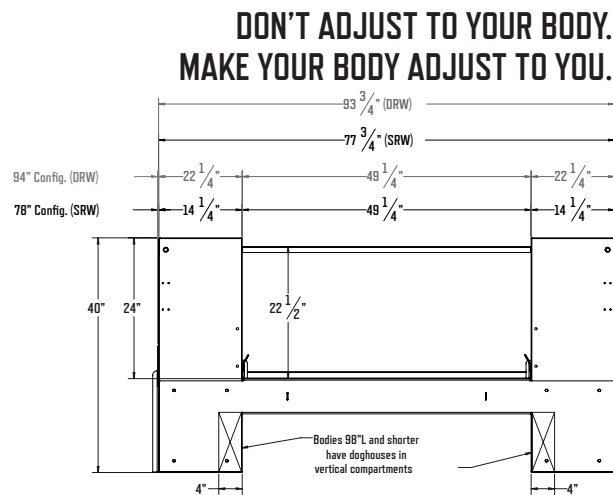

Chassis Style	C.A.	WIDTH	CARGO	DEPTH
98SW	56"	78"	49 ¹ / ₄ "	14 ¹ / ₄ "
98DW	56"	94"	49 ¹ / ₄ "	22 ¹ / ₄ "
110SW	60"	78"	49 ¹ / ₄ "	14 ¹ / ₄ "
110DW	60"	94"	49 ¹ / ₄ "	22 ¹ / ₄ "
134DW	84"	94"	49 ¹ / ₄ "	22 ¹ / ₄ "

SW - Single Wheel | DW - Dual Wheel



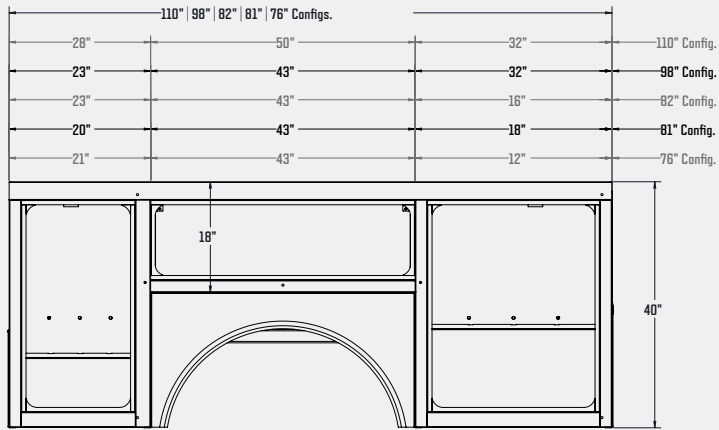

V CONFIGURATION

- 1st Vertical: Two adjustable shelves with two adjustable dividers per shelf
- Rear Vertical: One adjustable shelf with two adjustable dividers
- Available in 76", 81", 82", 98", 110" lengths

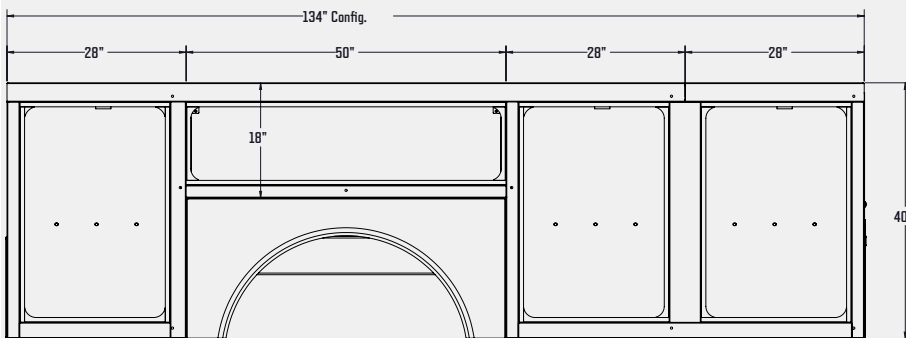

V CONFIGURATION (V134)

- 1st Vertical: Two adjustable shelves with two adjustable dividers per shelf
- 2nd Vertical: Two adjustable shelves with two adjustable dividers per shelf
- Rear Vertical: One adjustable shelf with two adjustable dividers



WHAT PART NUMBER IS RIGHT FOR YOU?

Be confident when you're ordering a CM Truck Bed that you're getting the right bed for the right truck.

- Truck bed parts # is listed below for the corresponding truck model. If no part # is listed, the truck bed is not available for this truck model.

Truck	SS	RD	SK	ER	TM	TMX	TMDLX	ALRD	ALSK	ALER	SB	SBA
GM SW LB	SS-01843842	RD-01843842	SK-01824242	ER-01824242		TMX-01844242		ALRD-01843842	ALSK-01844242	ALER-01844242	CMG8178	CMA8178
Ram SW SB	SS-01843842	RD-01843842	SK-01843842	ER-01823842				ALRD-01843842	ALSK-01843842	ALER-01843842	CMG7678	CMA7678
Ford SW SB 2017 to Present	SS-01843842	RD-01843842	SK-01844042	ER-01824042		TMX-01844042		ALRD-01843842	ALSK-01844042	ALER-01844042	CMG8278	CMA8278
Ford SW SB 2016 & Before	SS-01844038	RD--01844038	SK-01844038	ER-01824038		TMX-01844038		ALRD-01844038	ALSK-01844038	ALER-01844038	CMG8278	CMA8278
Ram DW MEGA	SS-01973842	RD-01973842	SK-01973842	ER-01973842				ALRD-01973842	ALSK-01973842	ALER-01973842		
GM SW LB	SS-02845842	RD-02845842	SK-02845642	ER-02825642		TMX-02845642		ALRD-02845842	ALSK-02845642	ALER-02845642	CMG9878	CMA9878
Ram SW LB	SS-02845842	RD-02845842	SK-02845842	ER-02824842		TMX-02845842		ALRD-02845842	ALSK-02845842	ALER-02845842	CMG9878	CMA9878
Ford SW LB 2017 to Present	SS-02845842	RD-02845842	SK-02845842	ER-02825842		TMX-02845842		ALRD-02845842	ALSK-02845842	ALER-02845842	CMG9878	CMA9878
Ford SW LB 2016 & Before	SS-02845638	RD-02845638	SK-02845638	ER-02825638		TMX-02845638		ALRD-02845638	ALSK-02845638	ALER-02845638	CMG9878	CMA9878
GM DW LB	SS-02975842	RD-02975842	SK-02975642	ER-02975642*	TM-02975642		TM-02975642DLX	ALRD-02975642	ALSK-02975642	ALER-02975642	CMG9894	CMA9894
Ram DW LB	SS-02975842	RD-02975842	SK-02975842	ER-02945842	TM-02975842		TM-02975842DLX	ALRD-02975842	ALSK-02975842	ALER-02975842	CMG9894	CMA9894
Ford DW LB 2017 to Present	SS-02975842	RD-02975842	SK-02975842	ER-02975842SD	TM-02975842SD		TM-02975842SDDLX	ALRD-02975842	ALSK-02975842	ALER-02975842	CMG9894	CMA9894
Ford DW LB 2016 & Before	SS-02975638	RD-02975638	SK-02975638	ER-02975638	TM-02975638		TM-02975638DLX	ALRD-02975638	ALSK-02975638	ALER-02975638	CMG9894	CMA9894
Ford/Ram 60" DW CC	SS-03946034SD	RD-03946034SD	SK-03946034SD	ER-03946034SD	TM-03946034SD		TM-03946034SDDLX	ALRD-03976034SD	ALSK-03946034SD	ALER-03946034SD	CMG11094	CMA11094
GM 60" DW CC 2020 to Present	SS-03946034SD	RD-03976034SD	SK-03926034SD	ER-03926034SD	TM-03926034SD		TM-03926034DLX	ALRD-03976034SD	ALSK-03926034SD	ALER-03926034SD	CMG11094	CMA11094
Ford 60" SW CC	SS-03846034SD	RD-03846034SD	SK-03846034SD	ER-03826034SD		TMX-03846034SD		ALRD-03846034SD	ALSK-03846034SD	ALER-03846034SD	CMG11078	CMA11078
Ford/Ram 84" DW CC	SS-04948434SD	RD-04978434SD	SK-04948434SD	ER-04948434SD	TM-04948434SD		TM-04948434SDDLX	ALRD-04978434SD	ALSK-04948434SD	ALER-04948434SD	CMG13394	CMA13394
GM 60" DW Med Duty SD		RD-03976034SD	SK-03976034GMSD	ER-03976034GMSD	TM-03976034GMSD		TM-03976034GMSDDLX				CMG11094	CMA11094
GM 84" DW Med Duty SD		RD-04978434GMSD	SK-04978434GMSD	ER-04978434GMSD	TM-04978434GMSD		TM-04978434GMSDDLX				CMG13394	CMA13394

- **SPECIAL OPTIONAL SIZES AVAILABLE FOR THIS TRUCK & BODY COMBINATION, SEE NEXT PAGE FOR DETAILS.**

If you do not see your truck or chassis, call our sales team to help find the correct parts number for your truck.

CM TRUCK BEDS OUTFITTING GUIDE

FORD		LENGTH	WIDTH	CAB-TO-AXLE	RUNNERS
1998-2016	Single Wheel Short Wheel Base	84"	84"	40"	38"
	Single Wheel Long Wheel Base	8'6"	84"	56"	38"
	Dually	8'6"	97"	56"	38"
2017-Present	Single Wheel Short Wheel Base	84"	84"	40"	42"
	Single Wheel Long Wheel Base	8'6"	84"	58"	42"
	Dually	8'6"	97"	58"	42"
All Model Years	Cab & Chassis (60" C/A)	9'4"	97" •	60"	34"
	Cab & Chassis (84" C/A)	11'4"	97" •	84"	34"
	Single Wheel Cab & Chassis	9'4"	84" •	60"	34"

• When ordering the SK model, use 94" width

RAM		LENGTH	WIDTH	CAB-TO-AXLE	RUNNERS
1998-2016	Single Wheel Short Wheel Base	84"	84"	40"	38"
	Single Wheel Long Wheel Base	8'6"	84"	56"	38"
	Dually	8'6"	97"	56"	38"
2017-Present	Single Wheel Short Wheel Base	84"	84"	38"	42"
	Single Wheel Long Wheel Base	8'6"	84"	58"	42"
	Dually	8'6"	97"	58"	42"
	Mega Cab Dually	84"	97"	38"	42"
All Model Years	Cab & Chassis (60" C/A)	9'4"	97" •	60"	34"
	Cab & Chassis (84" C/A)	11'4"	97" •	84"	34"
	Single Wheel Cab & Chassis	9'4"	84"	60"	34"

• When ordering the SK model, use 94" width

GENERAL MOTORS		LENGTH	WIDTH	CAB-TO-AXLE	RUNNERS
2000-Present	Single Wheel Short Wheel Base	84"	84"	42"	42"
	Single Wheel Long Wheel Base	8'6"	84"	56"	42"
	Dually	8'6"	94"	56"	42"
	Single Wheel Short Wheel Base	9'4"	97" •	60"	34"
	Single Wheel Long Wheel Base	11'4"	97" •	84"	34"
	Dually	9'4"	84"	60"	34"

• When ordering the SK model, use 92" or 94" width

CM

TRUCK BEDS®



BUILT FOR YOUR SUCCESS. Since 1990, CM Truck Beds has offered a wide range of feature-rich, work-ready products built to withstand the test of time and deliver the ultimate in value. Headquartered in Kingston, Oklahoma, CM Truck Beds has over 150,000 square feet of manufacturing and employs more than 300 experienced laborers and sales associates. We're proud to be the leader in flat-bed truck bodies, and we're dedicated to providing the solutions you need to get the job done.

When searching for a dependable and good-looking truck body that will help on the job site, down the road, or on the ranch, look no further than CM Truck Beds. Our field-tested products fit not only the vehicles they connect with but also the customers who use them, day in and day out. We utilize category-leading hitches, toolbox latches, and headache racks in addition to offering the toughest steel and aluminum beds and service bodies on the market.

Additionally, our strong network includes more than 200 distributors across North America who specialize in aftermarket upfit and installation. Count on superior product quality, large onhand inventory, and attention to detail throughout the upfitting process. It's this dedication to providing real-world solutions that makes CM Truck Beds the go-to source for hardworking professionals.



833-268-7825 | CMTRUCKBEDS.COM