



Water Tank Truck Bodies

***Extracted from Full Scelzi Catalog
April 2022***



Key Features and Options on Scelzi Water Trucks



Three square Manholes on 4000 gallon tanks



Two 24" x 24" Manholes

3/16" thick steel tank skins welded inside and out

Driver and passenger-side Adjustable Spray Fittings



2.5" Hydrant Fill Pipe

Optional Hose Reel

Front and Rear Spray Bars

Heavy Duty Steel Ladder

24" Stinger Storage with lockable lid

Cab control box



Unique Scelzi Water Tank Features:

- A-Rubber Mounts between the long sill and chassis to minimize vibration
- B-Spring tank mounts to act as shock absorbers independent of the chassis



Optional LED Enhanced Light Kit



Optional 1/4" Thick Belly Steel Overlay



Photos may contain optional equipment - verify your specifications when you order.

WT-2000

2,000 Gallons

Standard Specifications

Standard

- Features:**
- Chelsea Air Shift PTO
 - 4" x 3" Berkeley water pump (750 GPM)
 - Spicer PTO Driveline
 - 4" x 4" Water Manifold
 - 3" Standard Air Valves
 - 3" Slip on splash spray heads for front
 - 3" x 53" Front spray bar with mounting brackets
 - 3" Slip on splash spray heads for rear
 - 3" x 53" Rear spray bar with mounting brackets
 - 3" Adjustable driver side spray with VIC clamps
 - 3" Adjustable passenger side spray with VIC clamps
 - One control box inside cab with (6) air switches and Air control for PTO
 - 1-1/2" Gate valve at manifold
 - 3/4" Gate valve at manifold
 - 4" Water tank mounts with 3/4" bolts
 - One set of water tank fenders with hooks for hoses
 - OEM Tail Stop & turn rear lights
 - 2-1/2" Red marker lights seal beam
 - 2-1/2" Amber marker lights seal beam
 - 36" Rubber mud flaps
 - 24" Stinger at rear with lockable lid
 - 1/2" Sight gauge at rear

Options:

- Hot shift PTO for Allison Transmission
- Upgrade to CLA – Val Air Valves
- 1/4" Thick overlay "Belly" at lower level of standard 3/16" thick tank, which significantly slows "rot-out" of bottom of tank
- 6" Diameter gravity water tank dump valve at rear bottom of tank with "Fan Nozzle".

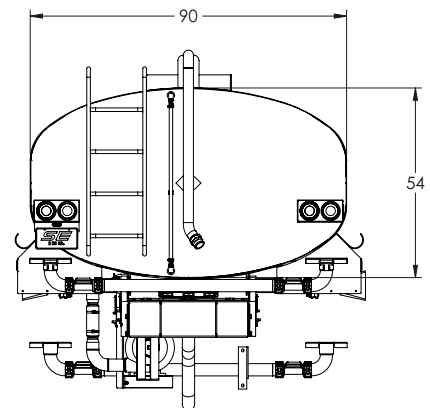
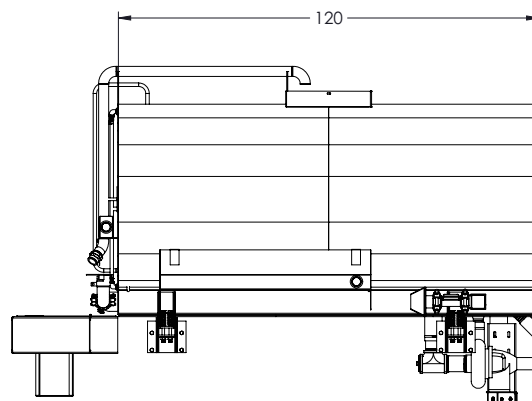
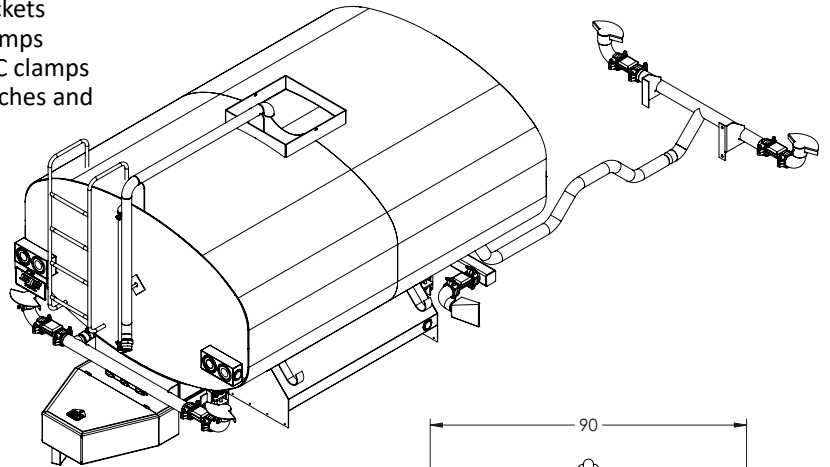



Photos may contain optional equipment - verify your specifications when you order.

WT-2500

2,500 Gallons

Standard Specifications

Standard Features:

- Chelsea Air Shift or Hot Shift PTO
- 4" x 3" Berkeley water pump (750 GPM)
- Spicer PTO Driveline
- 4" x 4" Water Manifold
- One set of water tank fenders with hooks for hoses
- 4" Water tank mounts with 3/4" bolts
- OEM tail stop & turn rear lights
- 3" Standard Air Valves
- 3" Slip on splash spray heads for front
- 3" x 53" Front spray bar with mounting brackets
- 3" Slip on splash spray heads for rear
- 3" x 53" Rear spray bar with mounting brackets
- 3" Adjustable driver side spray with VIC clamps
- 3" Adjustable passenger side spray with VIC clamps
- One control box inside cab with (6) air switches and Air control for PTO
- 1-1/2" Gate valve at manifold
- 3/4" Gate valve at manifold
- 2-1/2" Red marker lights seal beam
- 2-1/2" Amber market lights seal beam
- 36" Rubber mud flaps
- 24" Stinger at rear with lockable lid
- 1/2" Sight gauge at rear

Options:

- Hot shift PTO for Allison Transmission
- Upgrade to CLA – Val Air Valves
- 1/4" Thick overlay "Belly" at lower level of standard 3/16" thick tank which significantly slows "rot-out" of bottom of tank
- 6" Diameter gravity water tank dump valve at rear bottom of tank with "Fan Nozzle".

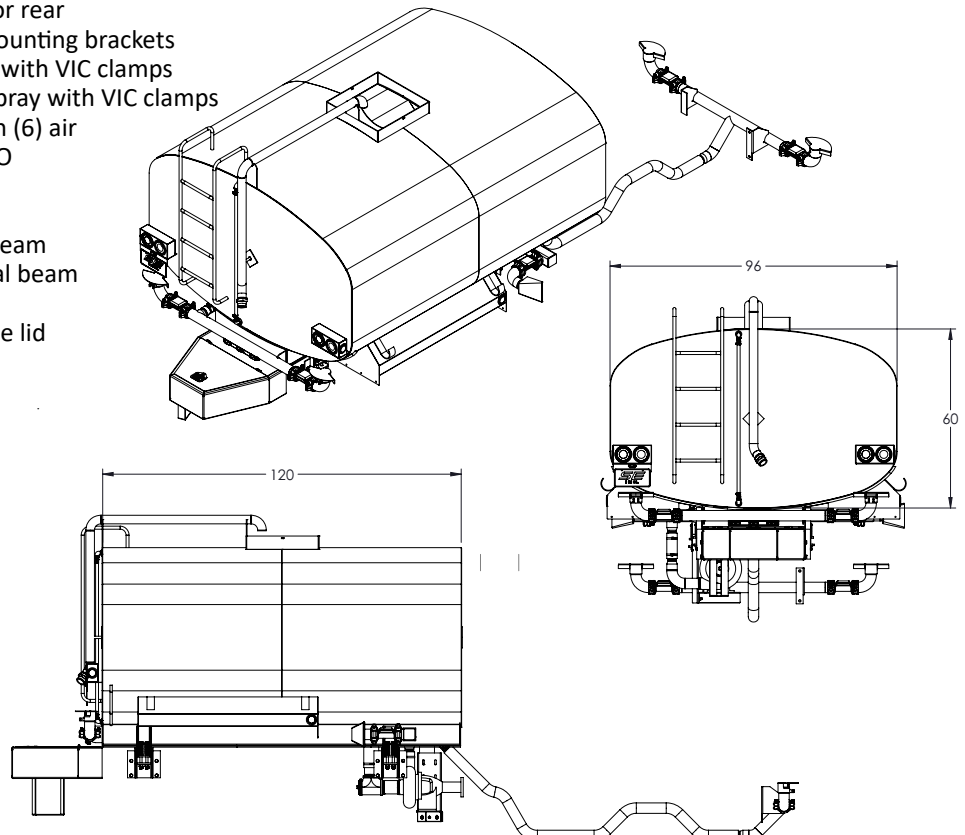



Photos may contain optional equipment - verify your specifications when you order.

WT-4000

4,000 Gallons

Standard Specifications

Standard

- Features:**
- Chelsea Air Shift PTO for manual transmission
 - 4" x 3" Berkeley water pump, (750 GPM)
 - Spicer PTO Driveline
 - 4" x 4" Water Manifold
 - 3" Standard Air Valves
 - 3" Slip on splash spray heads for front
 - 3" x 53" Front spray bar with mounting brackets
 - 3" Slip on splash spray heads for rear
 - 3" x 53" Rear spray bar with mounting brackets
 - 3" Adjustable S/S spray with VIC clamps
 - 3" Adjustable C/S spray with VIC clamps
 - One control box inside cab with (6) air switches and Air control for PTO
 - OEM tail stop and turn rear lights
 - 2-1/2" Red marker lights seal beam
 - 2-1/2" Amber marker lights seal beam
 - 36" Rubber mud flaps
 - 24" Stinger at rear with lockable lid
 - 1/2" Sight gauge at rear
 - 1-1/2" Gate valve at manifold
 - 3/4" Gate valve at manifold
 - 4" Water tank mounts with 3/4" bolts
 - One set of water tank fenders with hooks for hoses

Options:

- Hot shift PTO for Allison Transmission
- Upgrade to CLA – Val Air Valves
- 1/4" Thick overlay "Belly" at lower level of standard 3/16" thick tank, which significantly slows "rot-out" of bottom of tank
- 6" Diameter gravity water tank dump valve at rear bottom of tank with "Fan Nozzle".

