

MERCEDES-BENZ
SPRINTER



UPFIT GUIDE



**THE PERFECT FIT
FOR YOUR
TOUGHEST JOBS**

HELPING MOBILE TECHNICIANS WORK MORE EFFECTIVELY BY PROVIDING ORGANIZED STORAGE SOLUTIONS

**AT RANGER DESIGN,
WE BELIEVE MORE IS POSSIBLE.**

We believe work vehicles and the technicians that drive them can become more organized, more efficient, more productive and more profitable. At Ranger Design we're committed to bringing you the products and services that make that possible.

More means helping you choose the right work van for your application, as well as giving you engineering support and expert advice to help design the most efficient work space in your new vehicle.

More also means getting that new van outfitted and on the road faster, so you can start using it for the reason you bought it.

We're committed to bringing you more, because we believe more is possible.



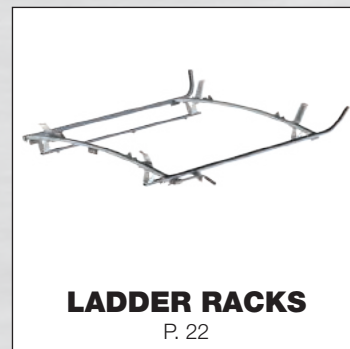
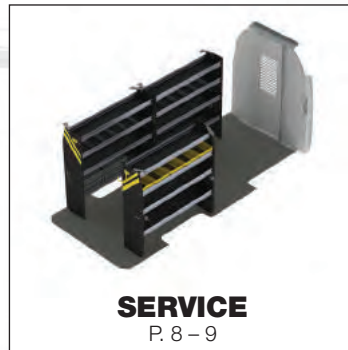

Large Distributor Network Across the Continent

Buy Ranger Design Quickship service is available through your local distributor. rangerdesign.com/find-distributor

Lead Time Quickship orders placed with Ranger Design before 1PM EST, will ship from our factory in the next business day.



All products shown in this upfit guide are available on Quickship

HOW TO USE THE LAYOUT GUIDE

INSIDE ROOF HEIGHT

To determine the maximum shelf height that can be used in the van.

PARTITION DEPTH

This indicates the space taken up by our partition for this vehicle. Please note that this measurement is determined by the partition that encroaches the most. Some partitions may take up less space. Take note that this measurement may not necessarily be on the floor.

DOOR OPENING

To determine where shelving will land in relation to the door opening. Use this measurement to determine the space available for drawer units.

DIMENSIONS IN RED

These dimensions indicate unique measurements for each wheelbase. Use red dimensions to determine the exact wheelbase of your van.

FLOOR SPACE

This area is usable floor space but due to curvature of the van there may not be the same available area at the roof. Please measure actual van for specific measurement at roof.

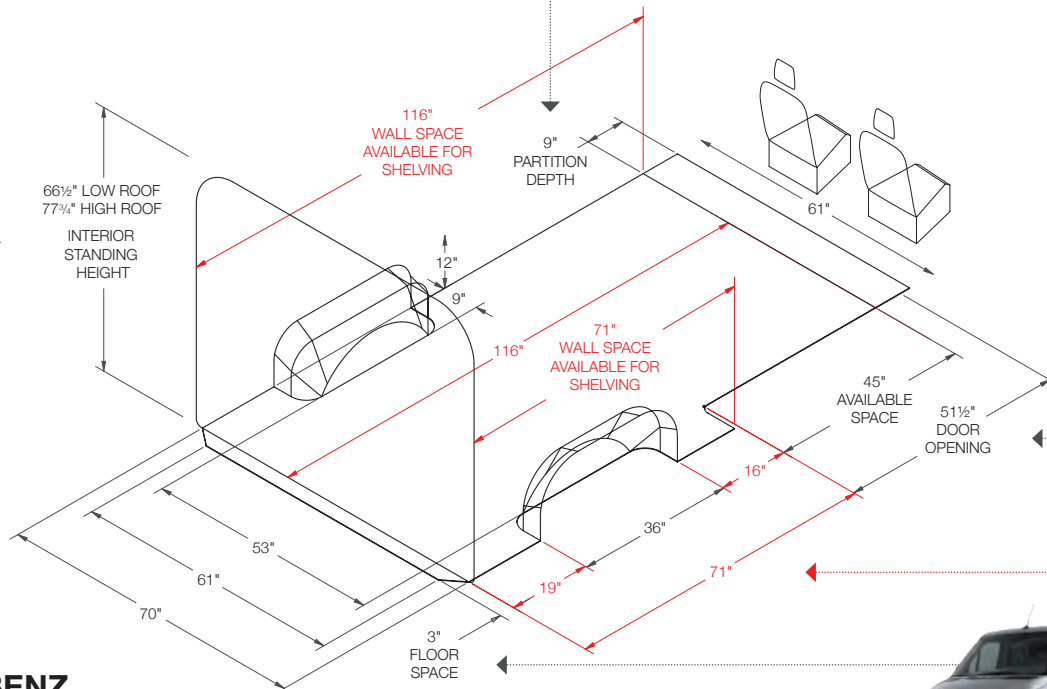

MERCEDES-BENZ SPRINTER

Regular 144" Wheelbase



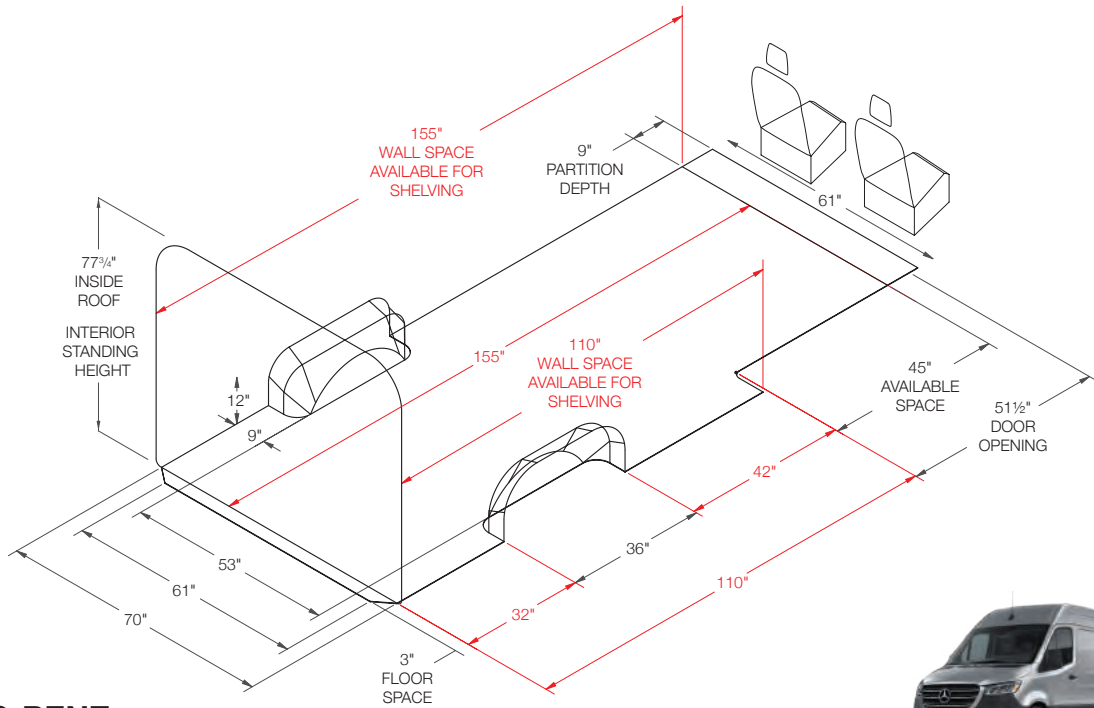

MERCEDES-BENZ SPRINTER

Long 170" Wheelbase

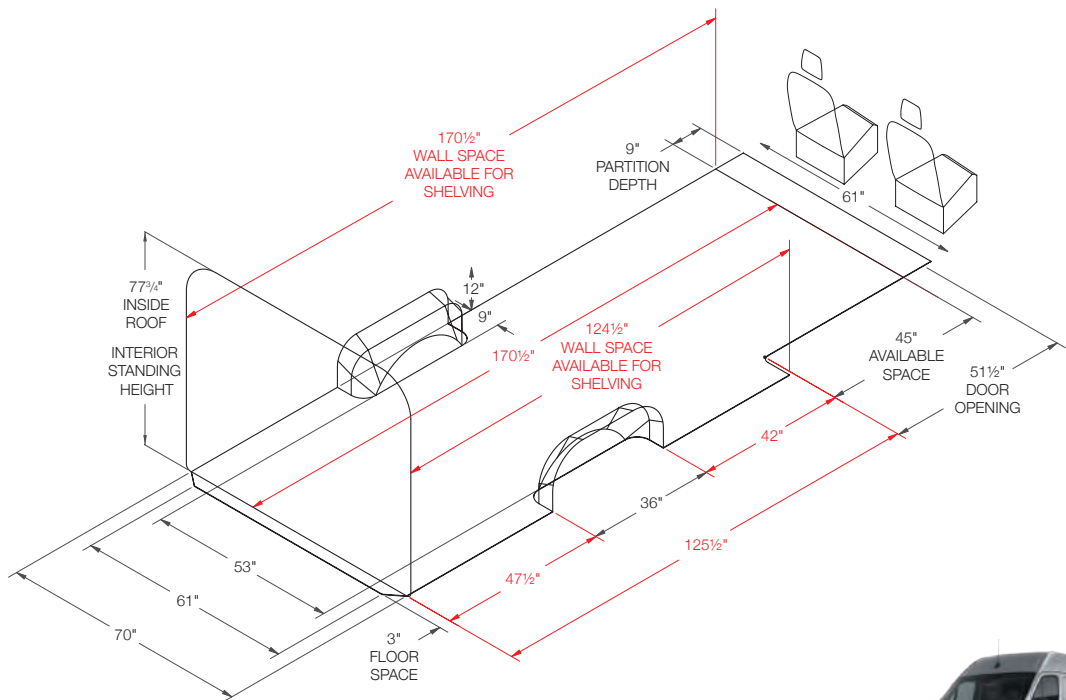

MERCEDES-BENZ SPRINTER

170" Extended Wheelbase

CONTRACTOR

CONTRACTOR

DHS-10 144" WHEELBASE

> High Roof



Qty	Part #	Description
1	6070	6" Hook, 3" opening, painted
1	C20-DH	Straight partition with perforated window, no access
1	N5-RS60-4	Steel shelving unit for high roof van, 14" D x 60" W x 62" H
1	N5-RS96-4	Steel shelving unit for high roof van, 14" D x 96" W x 62" H



DLS-10 Package* is identical to DHS-10 Package with the exception of the partition which changes to C20-DL.

*For Low Roof 144" wheelbase

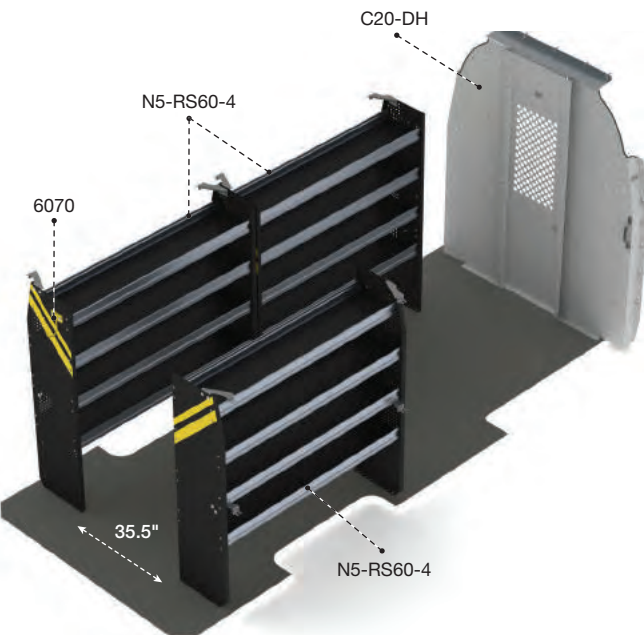
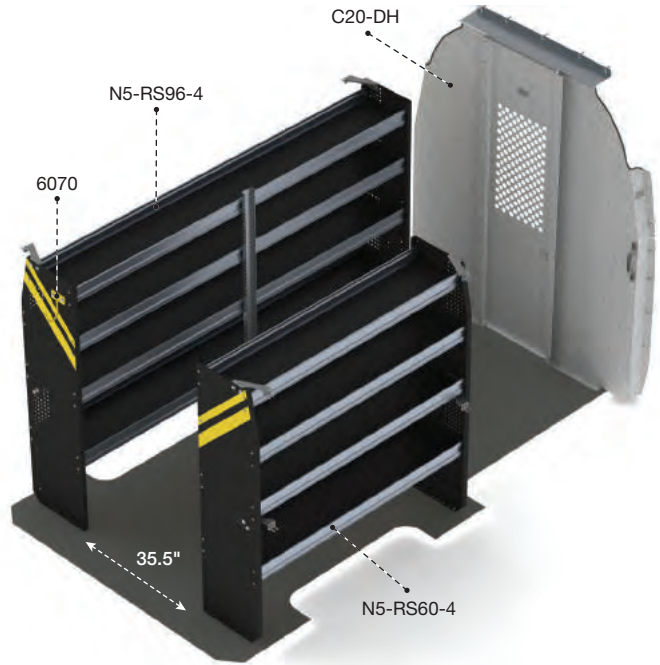

DHL-10

170" OR 170" EXTENDED WHEELBASE

> High Roof

Qty	Part #	Description
1	6070	6" Hook, 3" opening, painted
1	C20-DH	Straight partition with perforated window, no access
3	N5-RS60-4	Steel shelving unit for high roof van, 14" D x 60" W x 62" H





VISIT OUR WEBSITE FOR
OUR FULL-LINE OF PARTITIONS

DHS-10



6070

6" Hook,
3" opening,
painted



DHS-16

144" WHEELBASE

> High Roof



Qty	Part #	Description
1	6070	6" Hook, 3" opening, painted
1	6072	8" Swivel hook, 4" opening, painted
5	62-U1114	14" Deep plastic bin
2	62-UDR14	Set of 5 dividers for a 14" shelf
1	C20-DH	Straight partition with perforated window, no access
1	N5-RS60-4	Steel shelving unit for high roof van, 14" D x 60" W x 62" H
1	N5-RS96-4	Steel shelving unit for high roof van, 14" D x 96" W x 62" H
2	X50-B	Compact 2-drawer unit



DLS-16 Package* is identical to DHS-16 Package with the exception of the partition which changes to C20-DL.

*For Low Roof 144" wheelbase

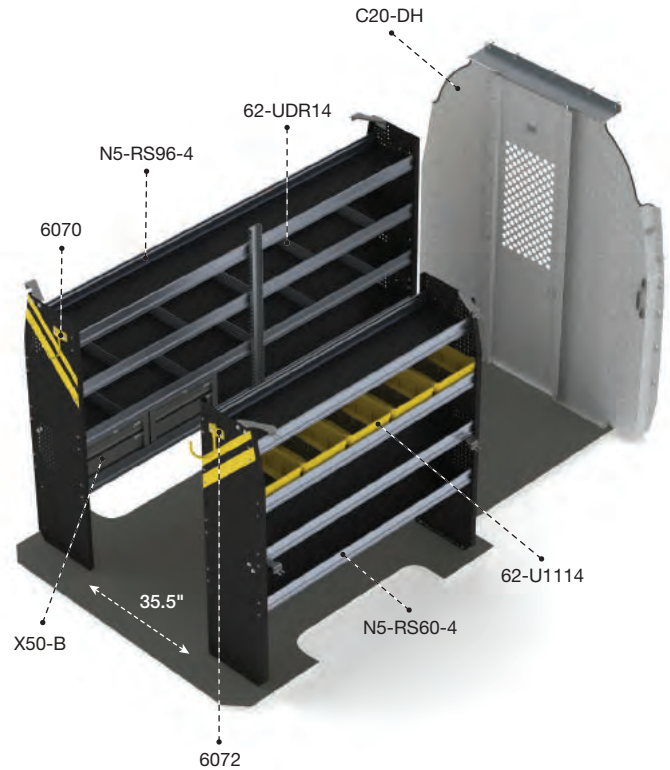

DHL-16

170" OR 170" EXTENDED WHEELBASE

> High Roof

Qty	Part #	Description
1	6070	6" Hook, 3" opening, painted
1	6072	8" Swivel hook, 4" opening, painted
5	62-U1114	14" Deep plastic bin
2	62-UDR14	Set of 5 dividers for a 14" shelf
1	C20-DH	Straight partition with perforated window, no access
3	N5-RS60-4	Steel shelving unit for high roof van, 14" D x 60" W x 62" H
2	X50-B	Compact 2-drawer unit

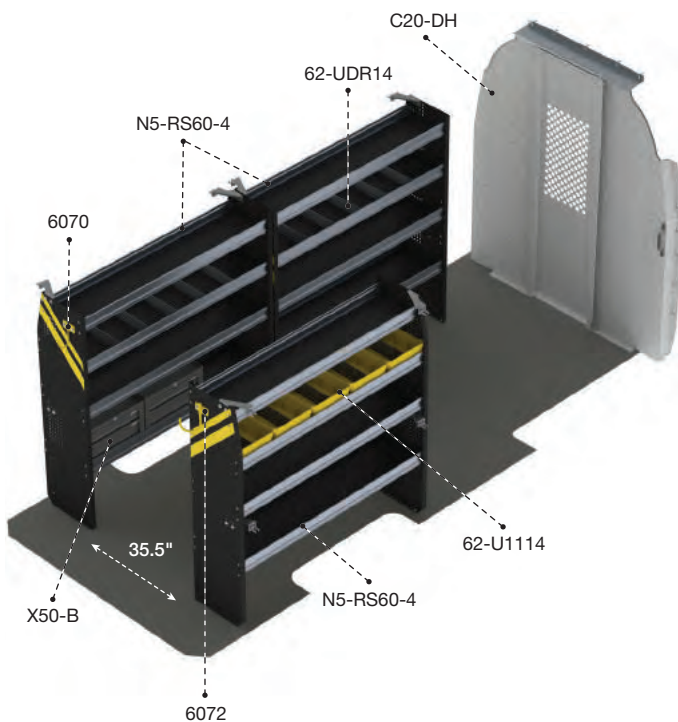

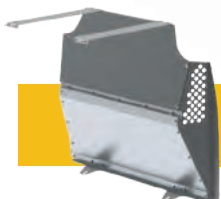

VISIT OUR WEBSITE FOR
OUR FULL-LINE OF PARTITIONS

DHS-16



6072

8" Swivel hook,
4" opening, painted



X50-B

2 Drawer cabinet



62-U1114

14" Deep plastic bin
with a center divider

FOR MORE ACCESSORIES, SEE PAGE 20.

ELECTRICAL

DHS-11 144" WHEELBASE

> High Roof



Qty	Part #	Description
1	6063	Paper holder, extra deep, 5 slots
1	6070	6" Hook, 3" opening, painted
1	6072	8" Swivel hook, 4" opening, painted
8	62-U1114	14" Deep plastic bin
2	62-UDR14	Set of 5 dividers for a 14" shelf
1	7124	Reel holder with two 5/8" diameter rods
2	77-U1048	Adjustable shelving door unit - 45" W - for 48" & 96" shelves
1	C20-DH	Straight partition with perforated window, no access
1	N5-RS60-4	Steel shelving unit for high roof van, 14" D x 60" W x 62" H
1	N5-RS96-4	Steel shelving unit for high roof van, 14" D x 96" W x 62" H
1	X50-B	Compact 2-drawer unit
1	X50-C	Compact 3-drawer unit

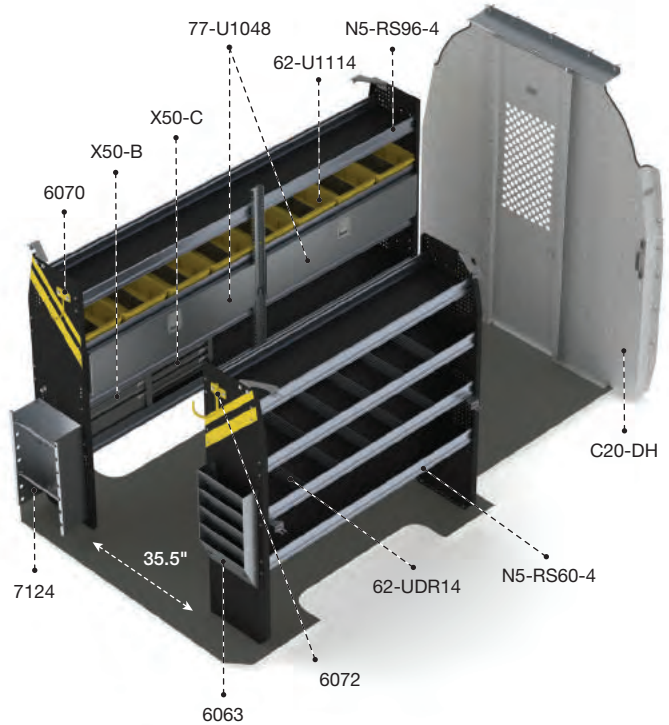

DLS-11 Package* is identical to DHS-11 Package with the exception of the partition which changes to C20-DL.

*For Low Roof 144" wheelbase

ELECTRICAL

DHL-11 170" OR 170" EXTENDED WHEELBASE

> High Roof

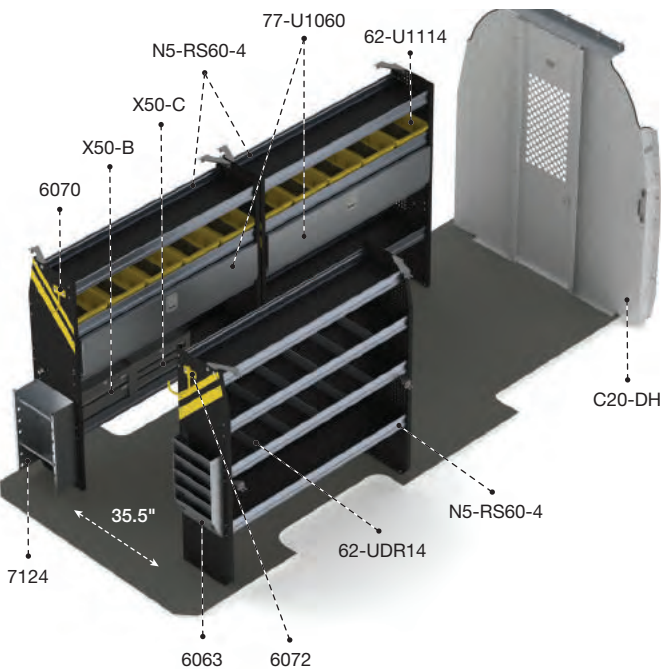

Qty	Part #	Description
1	6063	Paper holder, extra deep, 5 slots
1	6070	6" Hook, 3" opening, painted
1	6072	8" Swivel hook, 4" opening, painted
10	62-U1114	14" Deep plastic bin
2	62-UDR14	Set of 5 dividers for a 14" shelf
1	7124	Reel holder with two 5/8" diameter rods
2	77-U1060	Adjustable shelving door unit - 57" W - for 60" shelves
1	C20-DH	Straight partition with perforated window, no access
3	N5-RS60-4	Steel shelving unit for high roof van, 14" D x 60" W x 62" H
1	X50-B	Compact 2-drawer unit
1	X50-C	Compact 3-drawer unit



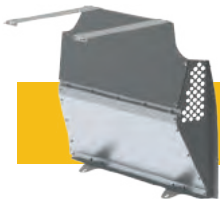

VISIT OUR WEBSITE FOR
OUR FULL-LINE OF PARTITIONS

DHS-11



62-U1110, 62-U1112, 62-U1114

Plastic bins with a center divider
Available in 10", 12" or 14" depths



62-U1212

2 Cross dividers for bin
Fits all size bins



77-U1042

Adjustable shelving door
unit 39" wide for a 84" shelf

FOR MORE ACCESSORIES, SEE PAGE 20.

DHS-12

144" WHEELBASE

> High Roof



Qty	Part #	Description
1	6008	3 Tier refrigerant rack for large bottles
1	6063	Paper holder, extra deep, 5 slots
1	6070	6" Hook, 3" opening, painted
1	6072	8" Swivel hook, 4" opening, painted
1	6088	Large aluminum bottle holder, with two black nylon straps
8	62-U1114	14" Deep plastic bin
2	62-UDR14	Set of 5 dividers for a 14" shelf
1	77-U1060	Adjustable shelving door unit - 57" W - for 60" shelves
1	C20-DH	Straight partition with perforated window, no access
1	N5-RS60-4	Steel shelving unit for high roof van, 14" D x 60" W x 62" H
1	N5-RS96-4	Steel shelving unit for high roof van, 14" D x 96" W x 62" H
2	X50-B	Compact 2-drawer unit

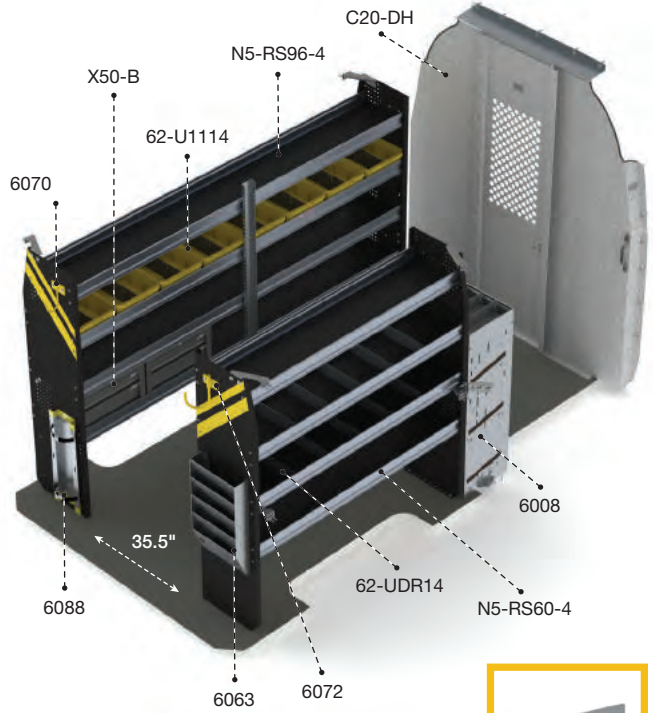

DLS-12 Package* is identical to DHS-12 Package with the exception of the partition which changes to C20-DL.

*For Low Roof 144" wheelbase



HVAC

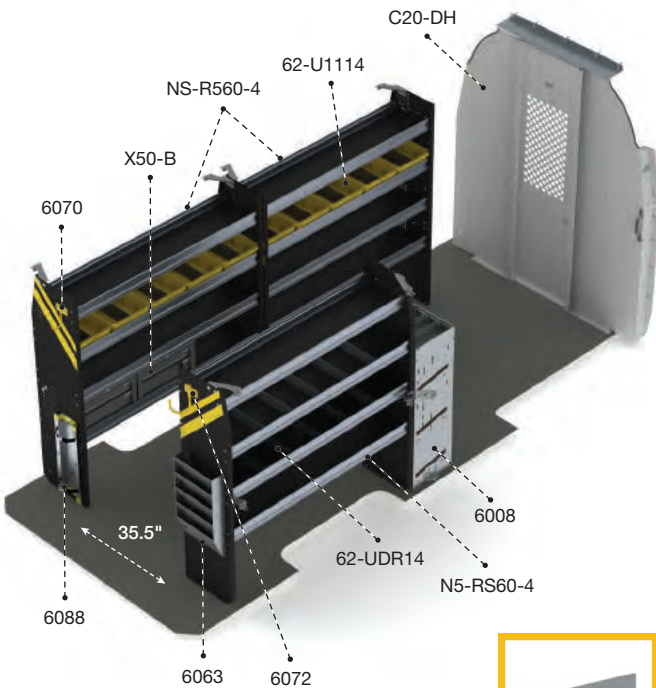

DHL-12

170" OR 170" EXTENDED WHEELBASE

> High Roof

Qty	Part #	Description
1	6008	3 Tier refrigerant rack for large bottles
1	6063	Paper holder, extra deep, 5 slots
1	6070	6" Hook, 3" opening, painted
1	6072	8" Swivel hook, 4" opening, painted
1	6088	Large aluminum bottle holder, with two black nylon straps
10	62-U1114	14" Deep plastic bin
2	62-UDR14	Set of 5 dividers for a 14" shelf
1	77-U1060	Adjustable shelving door unit - 57" W - for 60" shelves
1	C20-DH	Straight partition with perforated window, no access
3	N5-RS60-4	Steel shelving unit for high roof van, 14" D x 60" W x 62" H
2	X50-B	Compact 2-drawer unit





HVAC



VISIT OUR WEBSITE FOR
OUR FULL-LINE OF PARTITIONS

DHS-12



62-UDR14

Set of 5 dividers
for a 14" shelf

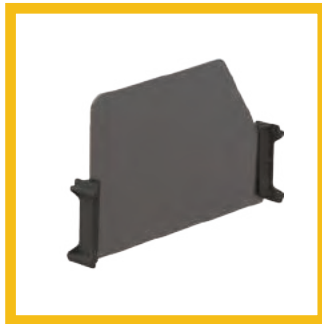

62-UDH14

Set of 5 high dividers
for a 14" shelf



6088

Large aluminum bottle holder,
with two black nylon straps



6008

3 Tier refrigerant
rack for large bottles

FOR MORE ACCESSORIES, SEE PAGE 20.

DHS-19

144" WHEELBASE

> High Roof



Qty	Part #	Description
1	84-U0063	Post assembly for fold-away shelving, 63"
2	84-U2036	Fold-away shelf tray, 20" D x 36" W
1	C24-DH	Straight walk through steel partition
2	F5-RA60-2	Fold-away unit, 2 levels, 25" D x 60" W x 63" H



DLS-19 Package* is identical to DHS-19 Package with the exception of the partition which changes to C24-DL.

*For Low Roof 144" wheelbase

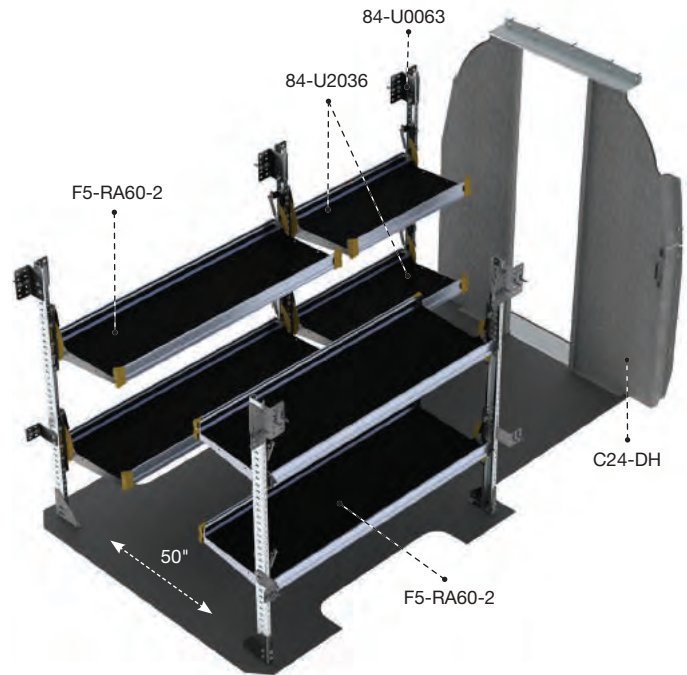

DHL-19

170" OR 170" EXTENDED WHEELBASE

> High Roof

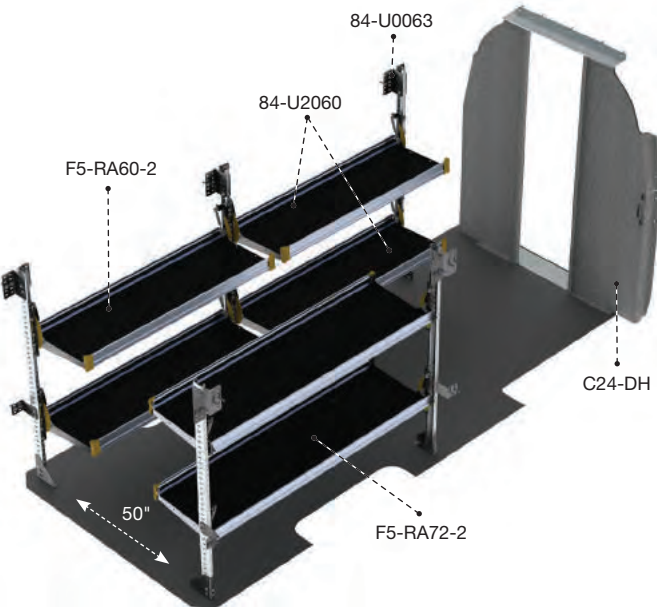

Qty	Part #	Description
1	C24-DH	Straight walk through steel partition
1	F5-RA60-2	Fold-away unit, 2 levels, 60" W x 63" H
1	84-U0063	Post assembly for fold-away shelving, 63"
2	84-U2060	Fold-away shelf tray, 20" D x 60" W
1	F5-RA72-2	Fold-away unit, 2 levels, 72" W x 63" H



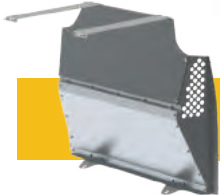

VISIT OUR WEBSITE FOR
OUR FULL-LINE OF PARTITIONS

DHS-19

DELIVERY

YOUR PERSONAL **FLEX SPACE**

Our fold-away shelves are designed to give you the ultimate in cargo flexibility

- Flexible
- Easy to use
- Tough



THE BENEFITS OF **ALUMINUM**

Weight saving equipment reduces total cost of ownership



Optimize fuel economy by decreasing overall van mass



Reduce vehicle maintenance and repairs caused by weight overload



Increase payload without sacrificing quality – it's a benefit offered only by aluminum

**Did you know that for every 100 lbs reduction,
you increase fuel economy by 1%?**

www.fueleconomy.gov

**Ranger Design is the leader for
aluminum upfits in North America**



DHS-27

144" WHEELBASE

> High Roof



Qty	Part #	Description
1	3020-DL	Countoured safety partition with glass window
1	5010	Partslider drawer
1	5020	Tool drawer 48" D x 14" W x 16" H
1	5048	Top edge
1	5069-2	2 Drawer cabinet
2	62-U5070	Partskeeper carry case with holder
1	6070	6" Hook, 3" opening, painted
1	6072	8" Swivel hook, 4" opening, painted
5	62-U1112	12" Deep plastic bin
15	62-U1114	14" Deep plastic bin
1	62-UDR12	Set of 5 dividers for a 12" shelf
2	62-UDR14	Set of 5 dividers for a 14" shelf
1	77-U1060	Adjustable shelving door unit - 57" W - for 60" shelves
1	N5-RA60-4	Aluminum shelving unit high roof van, 60", 14"D x 60" W x 62"H
1	N5-RA96-4	Aluminum shelving unit high roof van, 96", 14"D x 96" W x 62"H

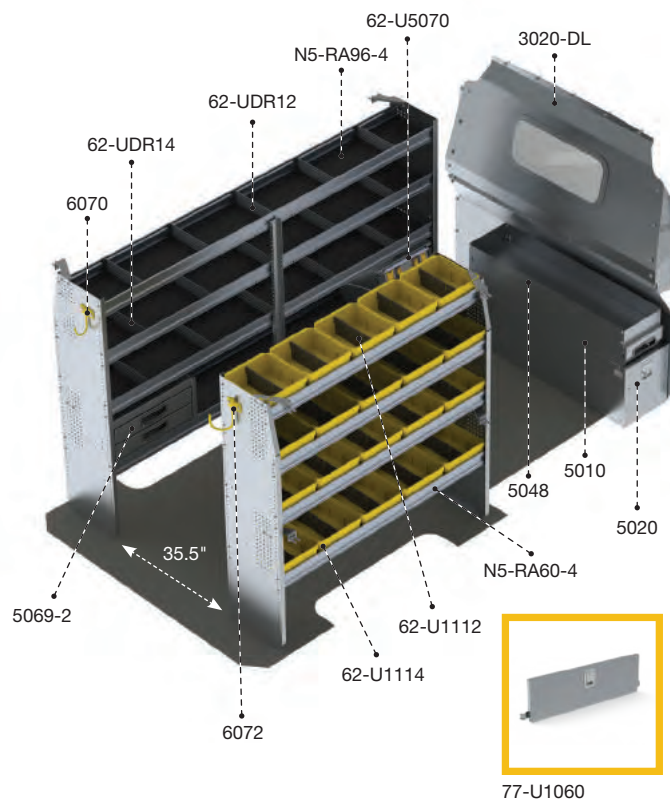

DLS-27 Package* is identical to DHS-27 Package with the exception of the partition which changes to 3020-DL.

*For Low Roof 144" wheelbase

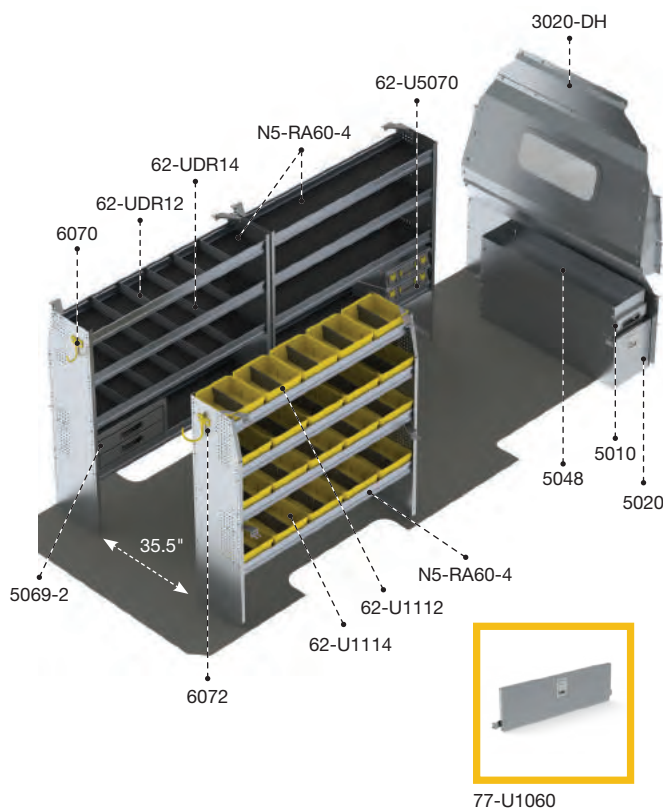

DHL-27

170" OR 170" EXTENDED WHEELBASE

> High Roof

Qty	Part #	Description
1	3020-DH	Countoured safety partition with glass window
1	5010	Partslider 48" D
1	5020	Tool drawer 48" D x 14" W x 16" H
1	5048	Top edge
1	5069-2	2 Drawer cabinet
2	62-U5070	Partskeeper carry case with holder
1	6070	6" Hook, 3" opening, painted
1	6072	8" Swivel hook, 4" opening, painted
5	62-U1112	12" Deep plastic bin
15	62-U1114	14" Deep plastic bin
1	62-UDR12	Set of 5 dividers for a 12" shelf
2	62-UDR14	Set of 5 dividers for a 14" shelf
1	77-U1060	Adjustable shelving door unit - 57" W - for 60" shelves
3	N5-RA60-4	Aluminum shelving unit high roof van, 60", 14"D x 60" W x 62"H



IT'S MORE THAN A FLOOR!

With incorporated mounting tracks for easy install for most Ranger Design products.

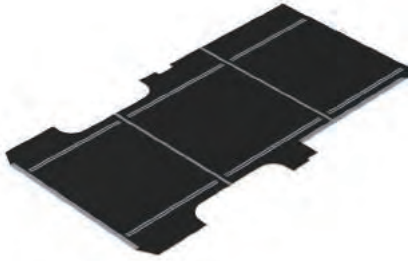

6540-DR

Mercedes Sprinter floor
for 144" wheelbase

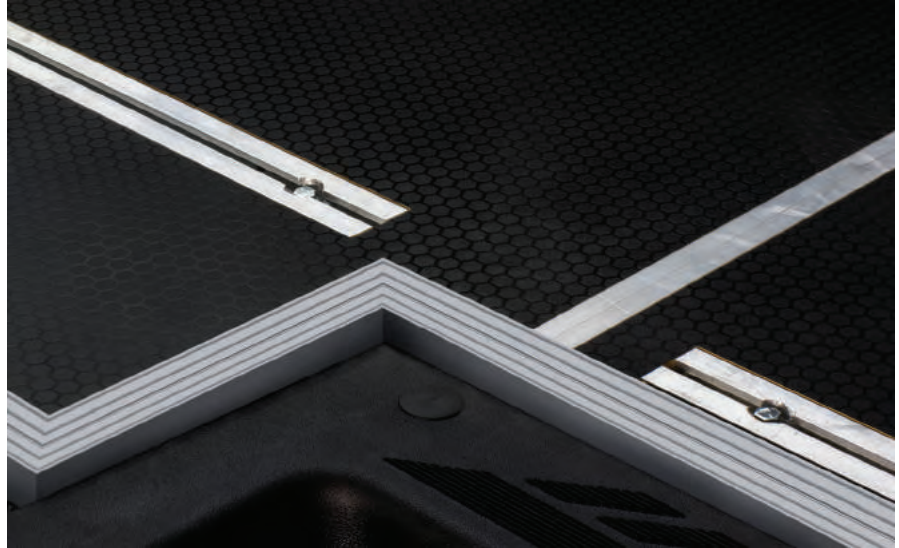

DRAWERS

Increase storage and organization with Ranger Design's line of drawer units



5048

Top Edge for drawers



5020

Tool Drawer 48"D x 14"W x 16"H



5010

Partslider Organizer 48"D x 12"W x 6"H



5025

Jumbo tool drawer 38"D x 16"W x 19"H

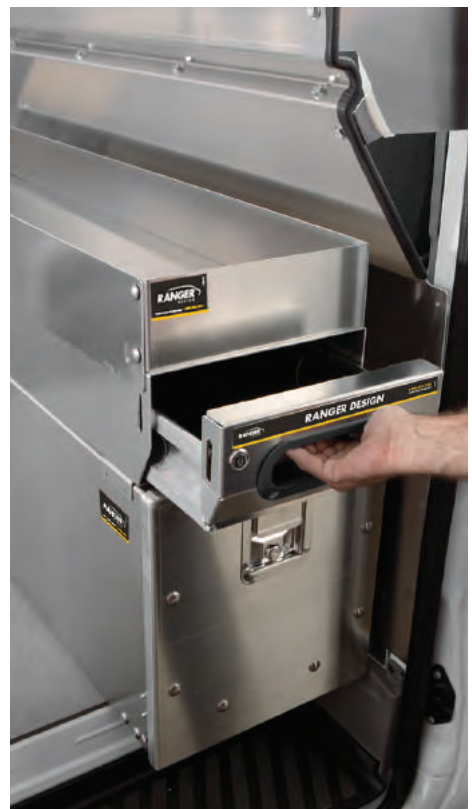

TOOL DRAWER TIP: Stack these drawers for the ultimate efficiency



STORAGE UNITS

Ergonomic storage solutions for the cargo space in your vehicle.



62-U5079
Partskeeper carry case



CAN BE INSTALLED EITHER WAY



62-U5070
Partskeeper carry case with holder, universal



62-U5074
Partskeeper floor mount cabinet with 4 carry cases, universal



N5-PS20-8
Partskeeper cabinet with 8 carry cases & 2 shelves universal



N5-LS16-1
Locker with top shelf, 16" D x 16" W x 63" H



S3-WA48-0
Workbench, with hardwood top, one end panel, Universal (drawer cabinet not included)



5060-5



S3-WA48-1
Workbench, aluminum with hardwood top, 1 shelf tray, Universal

ACCESSORIES

Choose the finishing details to tailor the upfit to your specific needs.



CARGO HOLDERS

Increase organization by giving a specific spot to store your equipment. Instead of being loose on the floor, your reels, cans etc. can be secured within easy reach from the door.



6010
Two level adjustable bottle holder



6057
Can holder



6068
Hard hat holder, painted wire



7124
Reel holder with two 5/8" diameter rods

STORAGE HOOKS

Keep frequently used items such as hats, vests and extension cords hanging within easy reach while on the road.



6070
6" Hook, 3" opening, painted



6073
Large aluminum movable hook, 6.5" opening

MAX STEP

Climbing in and out of your van several times a day can put a strain on your legs and back. The Max Step steps give tradesmen quick and easy access to their cargo space.



6550-DS
Max Step

SEAT COVERS

Keep your cab looking just like new with tight custom fit seat covers. The water & stain resistant fabric keeps your seats looking clean and increases resale value.



6257-19
(SPRINTER 2019)
Seat covers

LED LIGHTING

Keeps the cargo space bright, making visibility easy, no matter what time of day or night. Eliminate any chance of injury when searching through your tools in the dark.



6092-42
Universal LED light kit for trucks and vans (12V DC / 1200 Lm / 10W)

GRAB HANDLE

It is always useful to have something to hold onto when climbing into your van. Grab handles can also be used to tie down extra cargo during transport.



6093-27
Large grab handle

WINDOW GRILLS

Protect your van against theft and prevent damage to the van during loading or unloading, with Ranger Design's window grills.

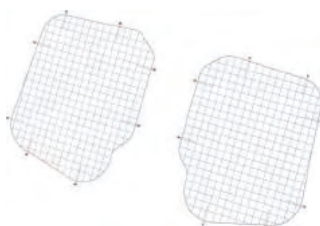

6107
Set of 2 rear window grills

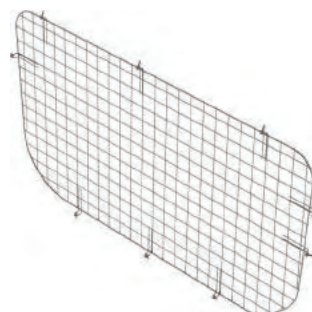

6117
Window grill, passenger side sliding door



STAY SAFE WITH RANGER DESIGN'S COMMERCIAL VEHICLE ACCESSORIES

LADDER RACKS



Cargo rack

Aluminum

			
1505-DH	144", 170", 170" Ext	High	—



Double clamp ladder rack



Aluminum

			
1530-DH	144", 170", 170" Ext	High	32 ft



Cargo + Rack

Aluminum

			
1506-DS	144"	Low	32 ft
1506-DH	170", 170" Ext	High	32 ft



Max Rack 2.0, Single side ladder rack

Aluminum

			
1870-DH	144", 170", 170" Ext	High	32 ft



Combination ladder rack

Aluminum

			
1525-DH	144", 170", 170" Ext	High	32 ft



Max Rack 2.0, Double side ladder rack

Aluminum

			
1880-DH	144", 170", 170" Ext	High	32 ft

Turn-Key Fleet Services



A Leader in Fleet Upfitting in North America

Our Proven Process to Deliver a Better Experience for Fleets:

1. Analysis

- › Cargo Needs Analysis
- › Custom 3D CAD Layouts
- › Hands-on Equipment Demo

2. Testing

- › Test Fitting
- › Pilot Build and Review
- › Package optimization based on technician feedback

3. Delivery

- › Delivery, production, installation planning and scheduling
- › Vehicle Status Tracking

4. Service

- › Dedicated Fleet Account Management Team
- › Ranger Design Distributor Service Support Network
- › Live Customer Service

Ship Through or Local Installation Across the continent for all Types of Cargo Vans

THE PERFECT FIT
FOR YOUR
TOUGHEST JOBS

When you want the **perfect upfit solution** for your work vehicle, turn to Ranger Design. **Tested for toughness**, Ranger Design's shelving and upfits will take whatever abuse you can dish out. Their **unsurpassed craftsmanship**, combined with ideal fit and finish, provide **a quiet ride with no rattles**.



RANGERTM
DESIGN

CUSTOMER SERVICE

cs@rangerdesign.com
1-800-565-5321

rangerdesign.com

