



*Building An American Legacy One Truck Body At A Time*





## *40 Years of Innovation, Quality, and Commitment to Excellence*

2019 is our 40th year in business. It is hard for us to believe how far we have come and where we are today.

As young men all three Scelzi brothers had a passion for cars and trucks. Mike, Jim, and Gary each spent time in related industries, but in the end they joined forces at Scelzi Enterprises to design and manufacture the best work truck bodies in the USA.



Mike, the oldest, started by building cars in his garage. At age 20 he was the youngest Mobile Gas Dealer ever, owning the station at the corner of Chestnut and Olive Avenues in Fresno, California. When he was 22 he began making custom wheels, and when he later sold the station he worked for a company that produced boat and car trailers, grain trailers, transfer dump trucks, flatbeds, and work truck utility bodies. This experience helped shape his future. He also briefly worked for a wholesale plumbing company.

Jim, at age 16, worked with Mike at the Mobile Station. When the station was sold Jim began working as a plasterer until he was about 25, when he became a partner with his father Monroe at the MJ Scelzi and Sons fuel distributorship. He worked part time at Scelzi Enterprises, which had recently been formed. Jim joined his brothers full time at Scelzi Enterprises in 2006.

Gary – the youngest brother – worked at Hallowell Chevrolet while attending high school. Once he graduated he joined his brother Mike at Scelzi Enterprises in 1979. In 1997 he focused on becoming a world-class drag racer, and continued this until his retirement from racing full time in 2008. During that 9 year span, Gary won four National Hot Rod Association (NHRA) World Championships. Although retired as an active racer himself, and fully committed to Scelzi Enterprises, Gary still maintains an interest in watching his two sons Dominic and Giovanni begin their own racing careers as part of the Gary Scelzi Motorsports organization.

Their father Monroe Scelzi always believed his sons should be in business together, so he loaned the brothers \$20,000 so they could open the first Scelzi Enterprises manufacturing facility in 1979, on Thesta Avenue in Fresno. Since then the success of the company has caused them to expand many times, and it presently utilizes more than 300,000 square feet of space, making Scelzi Enterprises the largest Truck and Body manufacturing facility in California.

Today the Scelzi Legacy continues, and our commitment to Quality is stronger than ever. As we fondly look back over the past 40 years, we are extremely grateful to the employees, dealers, and key partners who helped us reach this moment.

*Don't Settle For Less Than A Scelzi!*

### **SCELZI ENTERPRISES MISSION STATEMENT**

We utilize innovative truck body designs and an uncompromising Commitment to Quality to exceed our customer's expectations — providing value to our owners, our business partners, our team members, and our end users.

# Facilities

It started in our garage in Fresno, and then spread to a small building on Thesta Avenue. Today Scelzi Enterprises covers more than 300,000 square feet in California and Colorado.



Our Fresno facilities make Scelzi Enterprises the largest manufacturer of truck bodies on the West Coast. Covering 25 acres in Southwest Fresno and including 300,000 square feet of office and manufacturing space, we employ more than 400 employees of various skills and talents to contribute to the Quality of our organization.



We also have locations in Riverside, California (above) and in La Salle, Colorado (below) and partnerships with distributors in Oregon, Washington, and a growing list of other states. Wherever we are and whoever we select as a partner, we make sure the Scelzi Commitment to Quality is embedded deep into every product we manufacture, and in every person we employ.

Our Medium Duty Truck Body Facility opened in Fresno in 2017, vastly expanding our manufacturing capacity for larger truck bodies.



## SB - 80 - 79 - 49 - 38 - VO

	BODY TYPE	OVERALL BODY LENGTH	OVERALL BODY WIDTH	FLOOR WIDTH	COMPARTMENT HEIGHT	COMPARTMENT CONFIGURATION
WCB	Western Crane Body	80"	79"	49"	33"	H - Horizontal Compartments with Close Tops
CSH	Custom Sport Hauler					
CTFB	Contractor Body	98"	94"	54"	38"	V - Vertical Compartments with Close Tops
SB	Service Body SRW					
SBD	Service Body DRW	108"	96"	56"	43"	HO - Horizontal Compartments with Open Tops
SEC	Combo Body					
SFB	Scelzi Flat Bed	132"			60"	VO - Vertical Compartments with Open Tops
WFB	Western Flat Bed					
FBC	Flatbed - Custom	156"				
SBCR	Crown Service Body, SRW					
SBD CR	Crown Service Body, DRW					
SBD CRH	Crown RV Hauler Body					



### Compartment Configuration

H - Horizontal Compartments with Close Tops

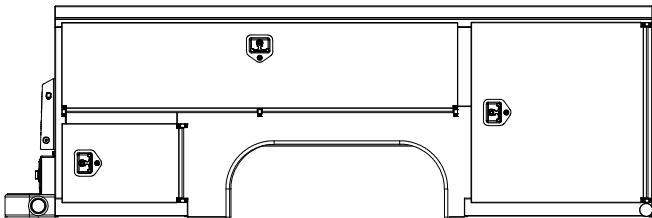

V - Vertical Compartments with Close Tops

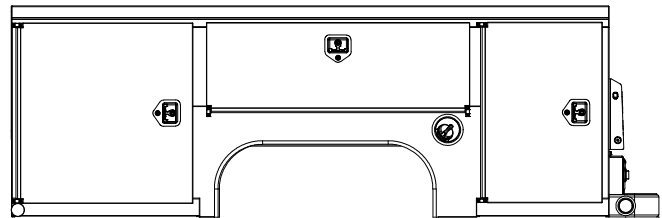

HO - Horizontal Compartments with Open Tops

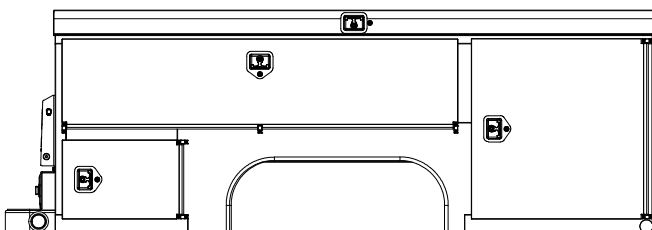

VO - Vertical Compartments with Open Tops

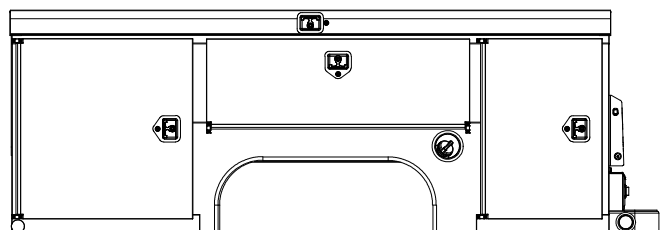



# The World's Best Truck Bodies



## Flatbed/Platform

SCELZI Flatbed  
WESTERN Flatbed

Page 7



## Landscaper/Gardener

8 x 10, 8 x 12, and 8 x 14 feet long

Page 11



## Cowboy

7 x 8, 8 x 8, and 8 x 9 feet long

Page 12



## Front Range Flatbed

NEW for 2019

Page 13



## RV Hauler

Page 14



## Contractor

7 x 9, 8 x 10, 8 x 12 and  
8 x 14 feet long

Page 15



## Super Contractor

8 x 12 foot Contractor Body with  
extra storage capacity

Page 16



## Combo

9, 10, 12, and 14 feet long

Page 17



## Service

SIGNATURE Service Body  
CROWN Service Body  
Service Body Insert

Page 18



## Super Structure

For 8600 GVW and higher

Page 30



## Crane

Western Crane Body 11 feet long

Page 31



## Welder

Page 32



## Dump

Page 33



## Chipper

12, 14, and 16 feet long

Page 38



## Water Truck

2000, 2500, and 4000 Gallon Tanks

Page 40

Parts and Accessories

Parts and Accessories

Page 45

SCELZI CLASSICS:  
Special Order Designs

- A-Frames
- Contour Body
- Cruiser Body
- Articulating Telescope Body
- Crane Body - Non Western

Page 53

CUSTOM DESIGNS

Page 55

# Why Do Scelzi Truck Bodies Last Longer Than Other Bodies?



## 1 More Robust Design

Over 1100 pounds, and no Salad Bar in sight!  
Only Scelzi Truck Bodies Can Handle This Load

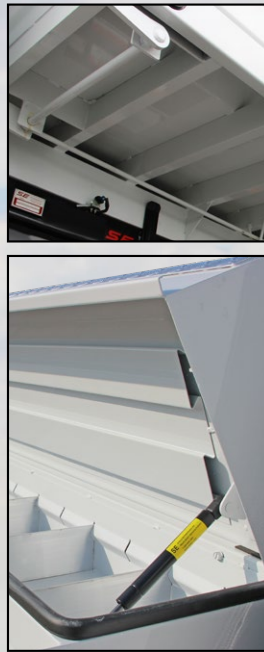

When you drive a SCELZI you can leave the tall ladder at home!



## 2 Premium Components



Thicker gauge steel for extended life



## 3 Precision Engineering, Welding and Assembly

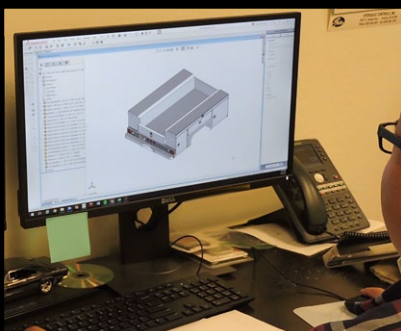

Scelzi Flatbed bodies are available in several different styles:

1. Scelzi Flatbed - with an "angled" tail plate and California Dock Bumper in back.
2. Western Flatbed - with a "squared" ICC Dock Bumper in back.
3. Flatbed Dump with hoist
4. Custom Flatbed



Western Flatbed



Scelzi Flatbed  
(shown with custom light package)



Flatbed Dump



Custom Flatbed (pg 55)

## Common Features and Options

### Available for Scelzi and Western Flatbeds

- Underbody Tool Box - See table below for options
- Top Mounted Tool Box - Close Top  
Available in 72", 96" and 108" long  
18" high - 18" deep
- Top Mounted Tool Box - Open Top  
Available in 48", 72", 96" and 108" long  
18" high - 18" deep

### Side Racks

- A.J. Bear style tapered polished stainless steel stakes with slats.  
Available in 12", 15", 18", 24", 36", 42", 48" heights.
- Other combinations of painted steel stakes or plywood, steel or aluminum siding can be ordered.

### Optional Tie Down Rail

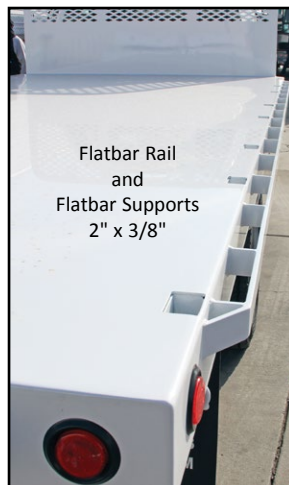

### Scelzi Flatbed Underbody Tool Boxes

LONG	HIGH	DEEP
24"	18"	18"
30"	18"	18"
36"	18"	18"
40" *	18"	18"
48"	18"	18"
60"	18"	18"

\* This is a special order item

Scelzi style flatbed - with an "angled" tail plate with California Dock Bumper in back.



**Scelzi Flatbed**



With  
Optional Toolbox



With  
Optional Toolbox and  
Custom Light Package

Photos may contain optional equipment - verify your specifications when you order.

- Flooring Choices:** Standard flooring options are hardwood, aluminum, or steel (smooth or diamond plate).  
**Stake Options:** Painted steel, stainless steel, hardwood, or none  
**Side Rack Options:** Hardwood, aluminum, or none

## Standard Body Lengths and Specifications

BODY TYPE	BED SIZE	TRUCK CA"	REAR WHEEL
SFB-7/8	7x8	56"	Single
SFB-7/9	7x9	60"	Single
SFB-8/8	8x8	56"	Duallie
SFB-8/9	8x9	60"	Dual
SFB-8/10	8x10	60"	Dual
SFB-8/12	8x12	84"	Dual
SFB-8/14	8x14	102"-108"	Dual
SFB-8/16	8x16	120"	Dual
SFB-8/18	8x18	144"	Dual
SFB-8/20	8x20	156"	Dual
SFB-8/22	8x22	168"	Dual
SFB-8/24	8x24	186"	Dual

### Standard Features

- Choice of 50-50 or One-Window Headboard
- 1/2" Rope Hooks on each Cross Member
- Tail Plate with California Dock Bumper
- OEM Taillights, Seal Beam Clearance Light
- Stainless Steel Gas Bezel
- Tapered A.J. Bear Style Stake Pockets
- Choice of color Black or White
- LED Clearance Lights Flush Mounted

### Optional Features

- Can be manufactured with any of the following:
  - 1-1/8" Hardwood or 7/8" Aluminum
  - Floors - 16" Crossmember
  - 12 Gauge Diamond Plate or 10 Gauge Smooth Steel over 7/8" Plywood
  - 3/16" Solid Diamond Plate Bed
  - 3/16" Smooth Steel Available

NOTE: No warranties offered on wood products





Western style flatbed - with a "squared" ICC Dock Bumper in back



Western Flatbed



Photos may contain optional equipment - verify your specifications when you order.

- Flooring Choices: Standard flooring options are hardwood, aluminum, or steel (smooth)
- Stake Options: Painted steel, stainless steel, hardwood, or none
- Side Rack Options: Hardwood, aluminum, or none

## Standard Body Lengths and Specifications

BODY TYPE	BED SIZE	TRUCK CA"	REAR WHEEL
W-7/8	7x8	56"	Single
W-7/9	7x9	60"	Single
W-8/8	8x8	56"	Dual
W-8/9	8x9	60"	Dual
W-8/10	8x10	60"	Dual
W-8/12	8x12	84"	Dual
W-8/14	8x14	102"-108"	Dual
W-8/16	8x16	120"	Dual
W-8/18	8x18	144"	Dual
W-8/20	8x20	156"	Dual
W-8/22	8x22	168"	Dual
W-8/24	8x24	186"	Dual

### Standard Features

- 50/50 Headboard with 3" Channel Radius Top
- Perforated Top Smooth Steel Bottom
- 7/8" Aluminum Floors are Optional
- 1/2" Rope Hooks on Each Crossmember
- Crossmember on 16" Centers
- ICC Dock Bumper
- OEM Taillights
- LED Seal Beam Clearance Lights Flush Mounted
- Painted White or Black
- 10 Gauge 6" Formed Rub Rails Front, Side & Rear
- 10 Gauge 4" formed Crossbars
- LED Clearance Lights Flush Mounted

### Optional Headboards

- Solid 10 Gauge Steel with 12"x24" Perforated Screen Window - NC
- Solid Smooth Steel with No Window Opening - NC

### Headboards

- 3" One Piece Contour Channel with 3" uprights and 10 gauge one piece perforated, smooth steel
- The 50-50 or the One-Window are standard. The Two-Window and the "A" Style are two of the many designs that can be ordered



Photos may contain optional equipment - verify your specifications when you order.

## Standard Body Lengths and Specifications

Available 10', 12', 14' and 16' Long

### CHOICE OF DECKING MATERIAL:

- 7/8" Aluminum Decking
- 7/8" or 1-1/8" Wood Decking
- 3/16" Smooth Steel
- 3/16" Diamond Plate
- Cross Member on 12" Centers
- Rope hooks on Each Cross Member
- Head Board 10 Gauge 12" x 24" Window
- ICC Bumper

### HOIST:

Scelzi Electronic and PTO Hoists Available

### SIDE RACKS:

- A.J. Baer Stainless Stakes with 3/4" Wood Material
- Solid or with a Gap
- 12", 15", 18", 24", 36", 42" or 48" Tall
- 1/2" Plywood Side Racks with Capping, Painted White or Black, 12", 15", 18", 24", 36", 42" or 48" Tall
- Removable Steel A.J. Baer Stakes with 18 Gauge Steel Slats Corrugated Painted White or Black
- 12", 15", 18", 24", 36", 42" or 48" Tall
- Non Removable Steel Side Racks 12" or 24" Tall, 10 or 14 Gauge

### BARN DOORS:

- Door Gates with Western Gate Latches for 12" or 24" Tall Doors
- Door Gates with or without Optional Cross Bars 8" Above Door.
- 36", 48" or 60" Tall Doors

### BINDER:

- Combo binder
- Recessed Combo Binder
- Sliding binder
- 3/4 Rope Hooks

### DUMP BED RECEIVER HITCHES:

- 1,000# Tongue Weight - 10,000 Pull Weight - Class 4
- 1,800# Tongue Weight - 18,000 Pull Weight - Class 5

### HITCHES FOR HEAVIER DUTY TOWING

- Recommended for 550 or Lower
- PH 15 - Pintle hitch with 1/2" Buck Plate or A-Frame

Recommended for 650 and Above

580J Premier H.D. Pintle 3/4" with Buck Plate



# LANDSCAPER/GARDENER Flatbed Dump Bodies



Photo Shows Optional Side Barn Doors and Tarp Cover

Photos may contain optional equipment - verify your specifications when you order.

## Standard Body Lengths and Specifications

Series	Bed Size	Side Rack Package Options
14.4	8 ft x 10 ft	Package A: 42" Solid steel with a HINGED horizontal door 60" wide, OR
11.2	8 ft x 12 ft	Package B: 42" Solid steel with a front vertical door 48" wide, OR
9.2	8 ft x 14 ft	Package C: 42" Solid steel with dual fold down doors
		Special Order: 1/2" Removeable plywood racks with steel stakes, western gate latches (photo below)

### Standard Features

- 10 Gauge Smooth Steel Floor
- Cross Member on 16" Centers
- Rope hooks on Each Cross Member
- Perforated 10 Gauge Head Board with 12" x 24" Window
- Rear Barn Doors
- Optional Side Barn Doors
- 42" Solid Steel side racks hinged to fold out at 21"
- Racks in 5 ft sections - One in front, one on driver side, and one curbside (passenger side)
- Class V Receiver hitch
- 7/4 RV plug
- Cargo area
- Covered with Polyurea for added Rust and Corrosion protection



Photo Shows Special Order Removeable Plywood Racks



- HOIST: Double Acting Scelzi Hoist. See page 33 for more hoist information

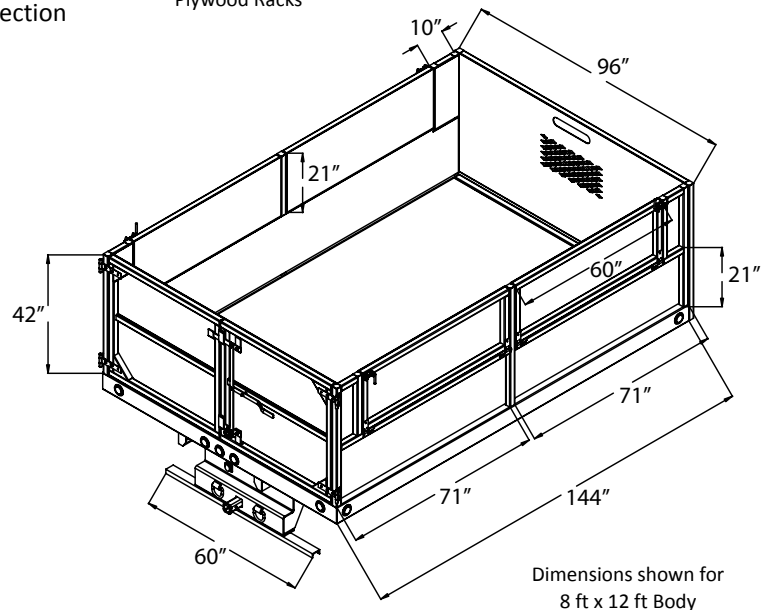



Photos may contain optional equipment - verify your specifications when you order.

Flooring Choices: Standard flooring options are hardwood or diamond plate steel

Body Sizes: 7 ft x 8 ft  
 8 ft x 8 ft, as shown in photos with wood flooring and 6" fold down side racks  
 8 ft x 9 ft body is also available



## Standard Specifications

NOTE: No warranties offered on wood products

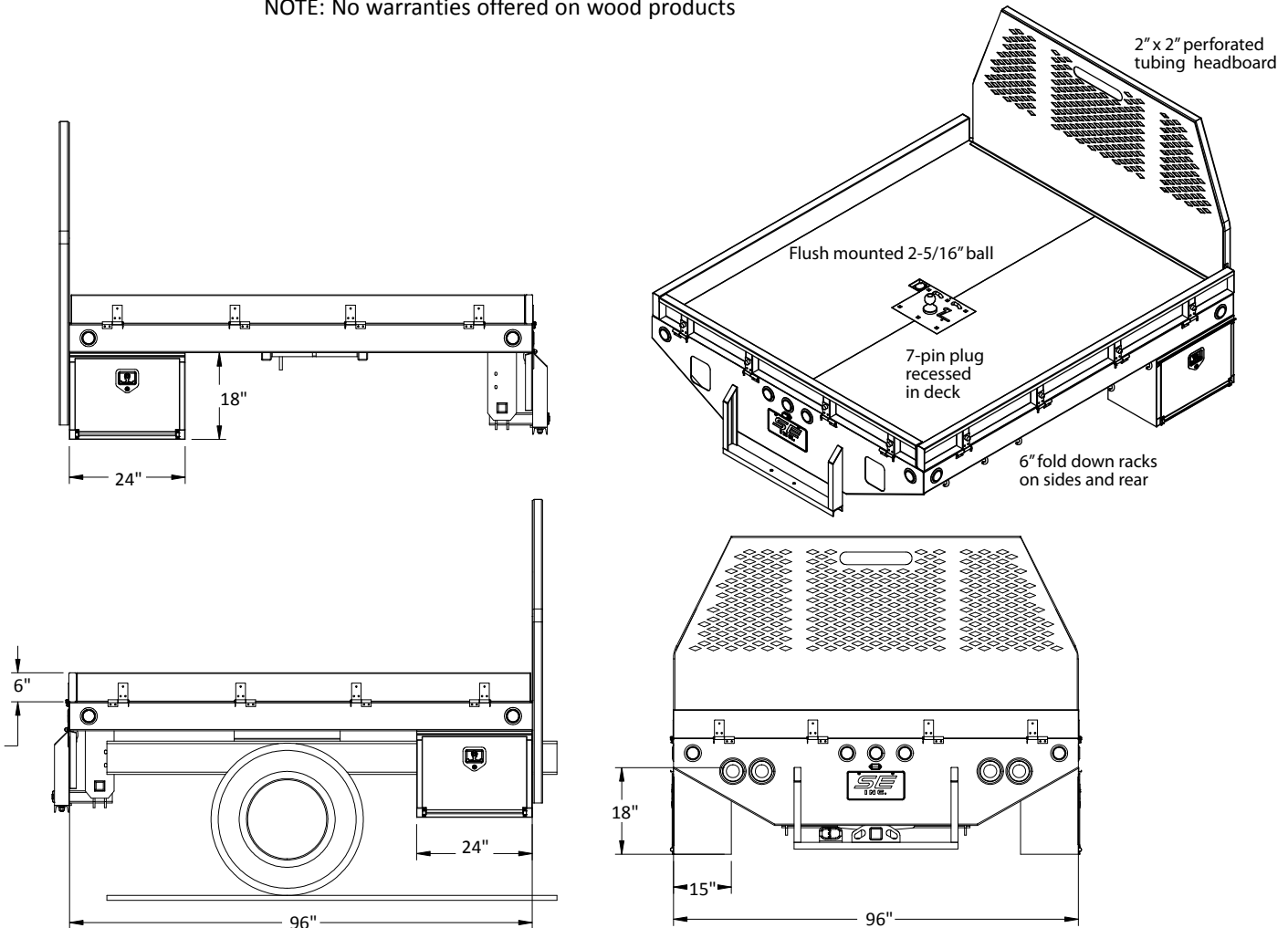

# FRONT RANGE FLATBED Bodies

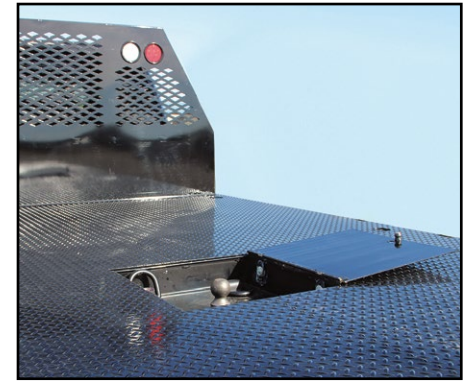

Integrated gooseneck hitch with 2-5/16" ball plus side flip lid

Photos may contain optional equipment - verify your specifications when you order.

Flooring/Sides: 1/8" diamond plate steel flooring and sides

## Standard Body Lengths and Specifications

Bed SIZE	Cab to Axle (CA)	Rear Wheel	Hitch	Tool Boxes
7 ft x 8.5 ft	56"	Single	Factory hitch and 7 way RV plug	30" Long x 18" High x 12" Deep tool intalled in front of rear wheels
8 ft x 8.5 ft	56"	Dual	Factory hitch and 7 way RV plug	30" Long x 18" High x 18" Deep tool intalled in front of rear wheels
8 ft x 9.5 ft	60"	Dual	Scelzi Class 5 hitch and 7 way RV plug	36" Long x 18" High x 18" Deep tool intalled in front of rear wheels
8 ft x 11.5 ft	84"	Dual	Scelzi Class 5 hitch and 7 way RV plug	48" Long x 18" High x 18" Deep tool intalled in front of rear wheels

### Standard Equipment For All Sizes

- 1/8" Diamond Plate Cargo Floor & Sides
- Rear and Front 1/8" smooth steel tail plate w/6" tapered corners @ rear
- Front smooth steel 6" rail
- 4" x1/8" formed cross-members 6" integrated thick
- Longsills AJ Baer tapered stake pockets sides & rear
- Bolt-on tapered head board with LED seal
- Beam lights built into top corners of headboard – stop, turn, tail and back-up
- Rear tail apron with custom ICC Dock
- Bumper LED lights – stop, turn, tail and back-up
- Camera – installation
- All LED marker lights
- Integrated goose neck hitch with 2 5/16 ball recessed in floor with slide flip lid with 7 way RV plug #12707
- 1/2" Rope hook installed
- Black powder coated

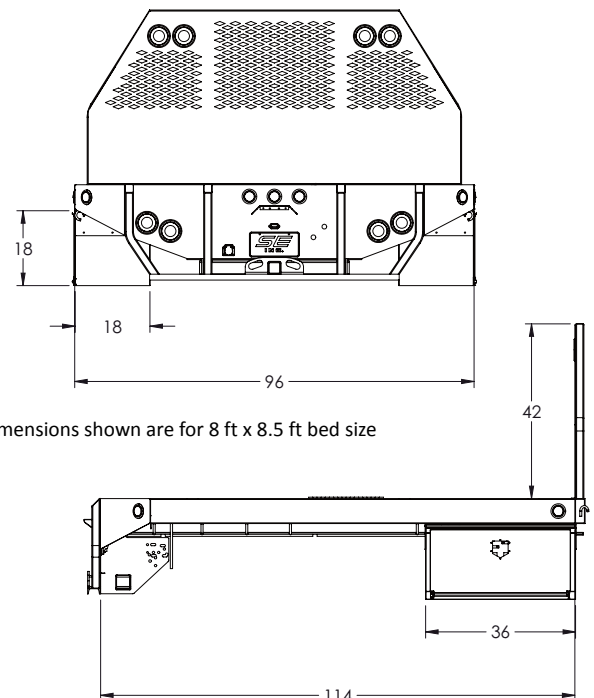

Dimensions shown are for 8 ft x 8.5 ft bed size



SBDCRH-108-94-49-33-V



SBDCRH-108-94-49-33-VO

Photos may contain optional equipment - verify your specifications when you order.

Photos: Above LEFT: SBDCRH-108-94-49-33-V in Package "A" configuration with 33" tall front compartments

Above RIGHT: SBDCRH-108-94-49-33-VO in Package "B" configuration with 33" tall front compartments

## Standard Body Lengths and Specifications

Body Length: 108 inches

### Options

Hitch can be B&W turn over ball 1500R.

### Available Models:

VO - Vertical Compartments with open tops.

V - Vertical Compartments with close tops.

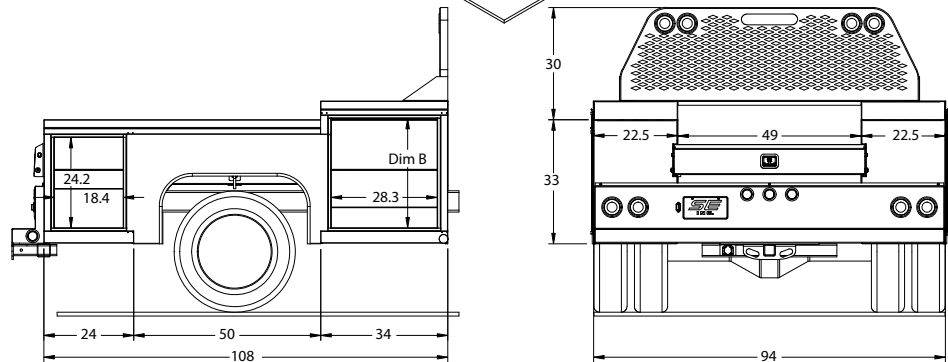
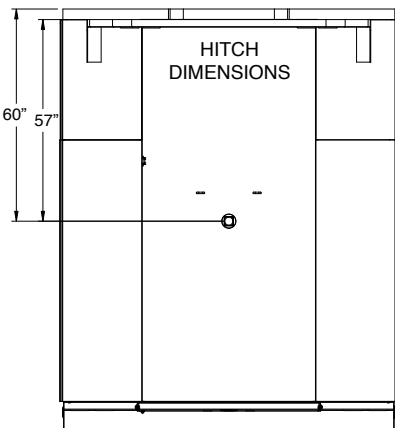
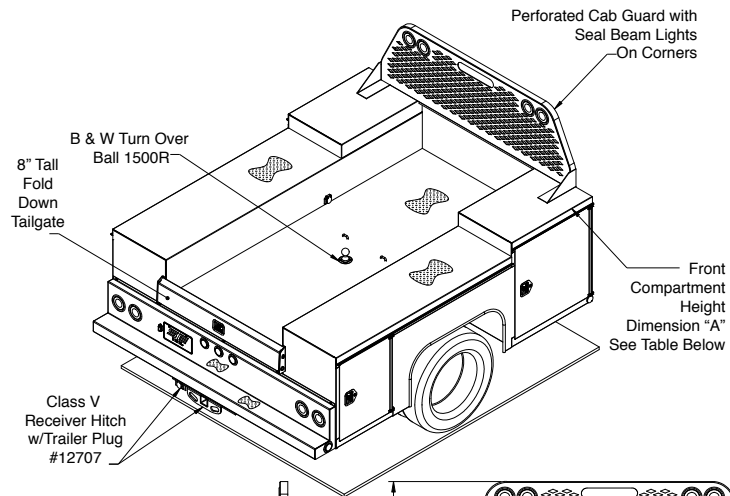

Model	Hitch Type Configuration	Dimensions	
		A	B
A	Recessed Gooseneck, shown above	33	24.2
B	B&W Turn Over Ball 1500R	33	24.2
C	Recessed Gooseneck, shown above	38	29.3
D	B&W Turn Over Ball 1500R	38	29.3

# CONTRACTOR FLATBED Bodies



Photos may contain optional equipment - verify your specifications when you order.

## CTFB-8/12 (84 CA) Standard Specifications

Other Widths/Lengths Available: 7/9 • 8/10 • 8/14

**Body Dimensions:** 8 ft Wide x 12 ft Long (144 inches)  
**Other Bodies Available:**  
 7 ft Wide X 8.5 ft Long (108 inches) - 56 CA  
 8 ft Wide X 10 ft Long (120 inches) - 60 CA  
 8 ft Wide X 14 ft Long (168 inches) - 108 CA

**Color:** White

**Flooring/Rack Choices:** Wood floor and fold down side racks  
 OPTIONAL: Aluminum floor and fold down side racks

**Tool Boxes:** 96" x 18" x 18" top mount, open top (2 boxes)  
 60" x 18" x 18" underbody (2 boxes)

**Top Rack:** Removeable 3" x 2" x 120" wall with 2" legs and 3" x 2" removeable crossbars  
 Powder coated  
 OPTIONAL: Standard or fork lift accessible material rack  
 NOTE: No warranties offered on wood products



This photo shows CTFB-8/10

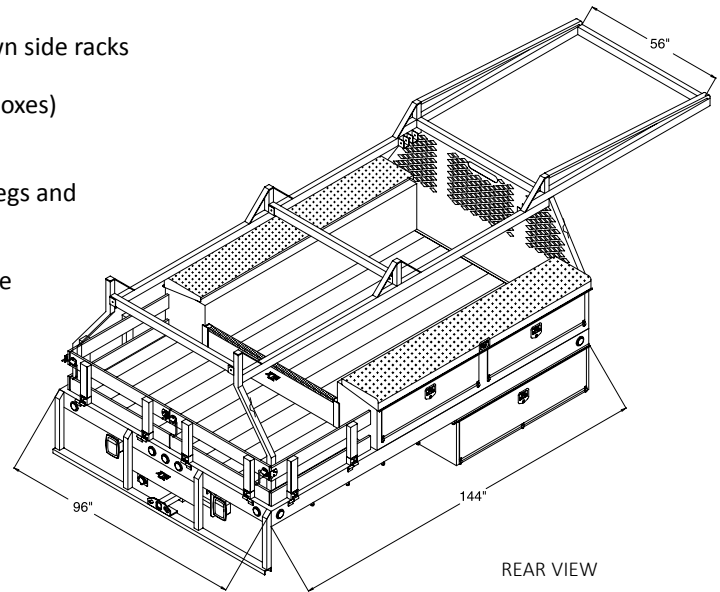

15" FOLD DOWN SIDE RACKS  
 SS STAKES

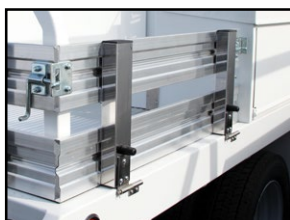

2x3 FORK ACC RACK

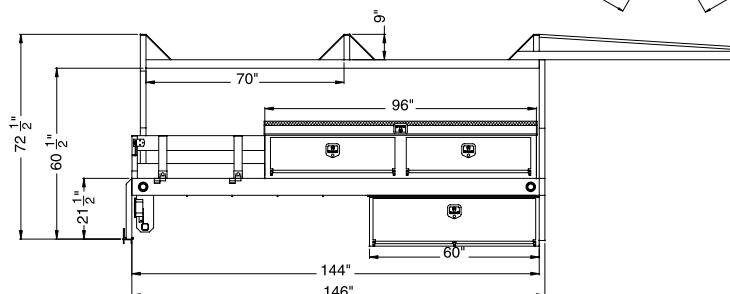

REAR VIEW

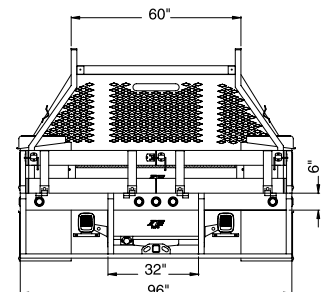

All drawings reflect dimensions for the most popular applications

# SUPER CONTRACTOR FLATBED Bodies



Photos may contain optional equipment - verify your specifications when you order.

## SCTFB-8/12 (84 CA) Standard Specifications

- Body Dimensions:** 8 ft Wide x 12 ft Long (144 inches)
- Color:** White
- Flooring/Rack Choices:** Wood floor and fold down side racks  
OPTIONAL: Aluminum floor and fold down side racks
- Tool Boxes:** 96" x 30" x 20" top mount, closed top (2 boxes)  
96" x 13" x 20" Shovel box - full length opening  
60" x 18" x 18" underbody (2 boxes)
- Compartments:** Bottom compartments with 1 roller drawer and 1 adjustable shelf on each side
- Top Rack:** Removeable 3" x 2" x 120" wall with 2" legs and 3" x 2" removeable crossbars  
Powder coated  
OPTIONAL: Standard or fork lift accessible material rack

NOTE: No warranties offered on wood products



Standard Item In Boxes For This Model Only

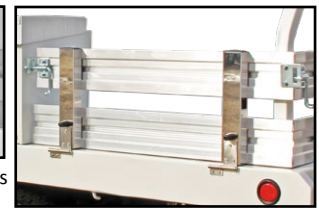

15" Fold Down Side Racks With Aluminum Slats and Stainless Steel Stakes



Wood Slats With Stainless Steel Stakes

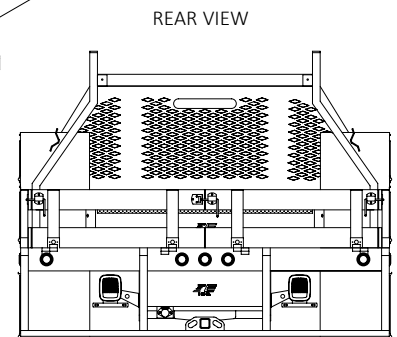
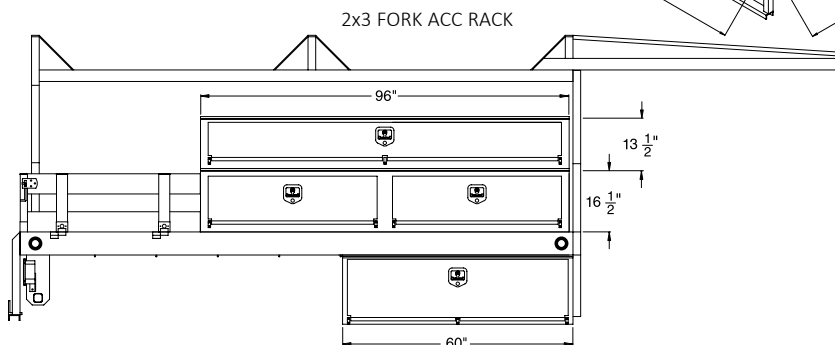
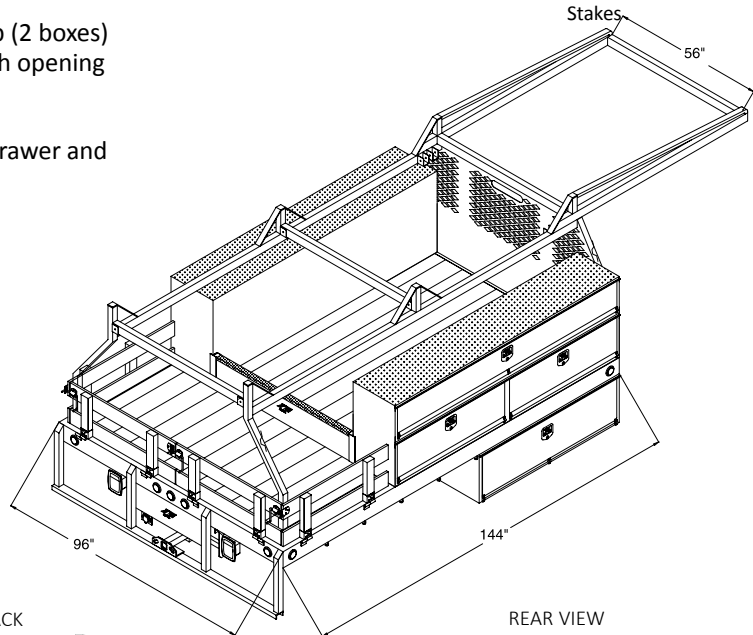



# COMBO Service Bodies



Photo shows  
SEC-144-94-49-38-VDO

Photos may contain optional equipment - verify your specifications when you order.

**SEC-144      12 ft      (84 CA)      Standard Specifications**  
**Other Lengths Available: 9 ft • 10 ft • 14 ft**

- Body Dimensions:      144 inches Long (12 ft) x 94 or 96 inches Wide  
 Other Bodies Available:  
     SEC-110 9 ft Long - 56-60 CA  
     SEC-120 10 ft Long - 60 CA  
     SEC-168 14 ft Long - 108 CA
- Rear Wheel:      Dual
- Color:      White
- Side Racks:      Steel floor with wood fold down side racks  
 OPTIONAL: Aluminum fold down side racks
- Storage Compartments:      Aluminum diamond plate on top  
 Height: 38 inches high
- Top Rack:      Powder coated Contractor style ladder rack

Photo shows SEC-110-96-51-38-VDO



Photo shows SEC-120-94-49-38-VDO

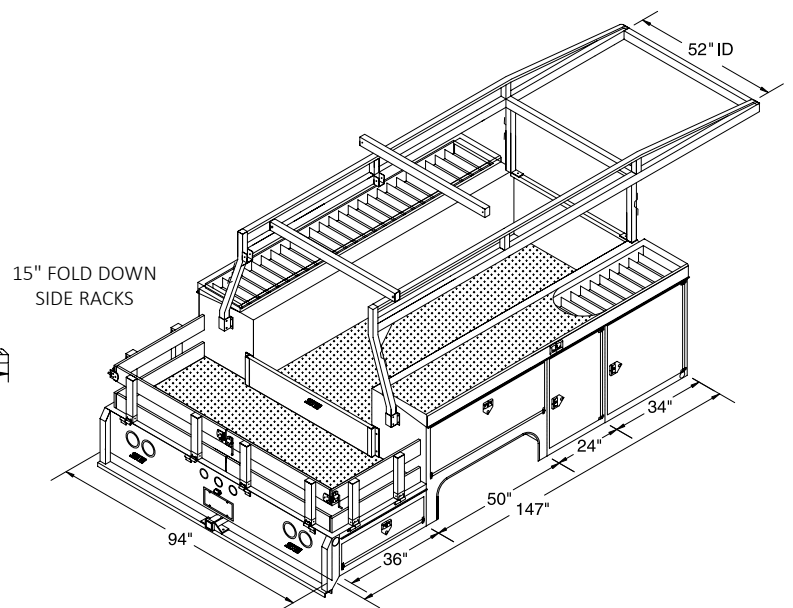
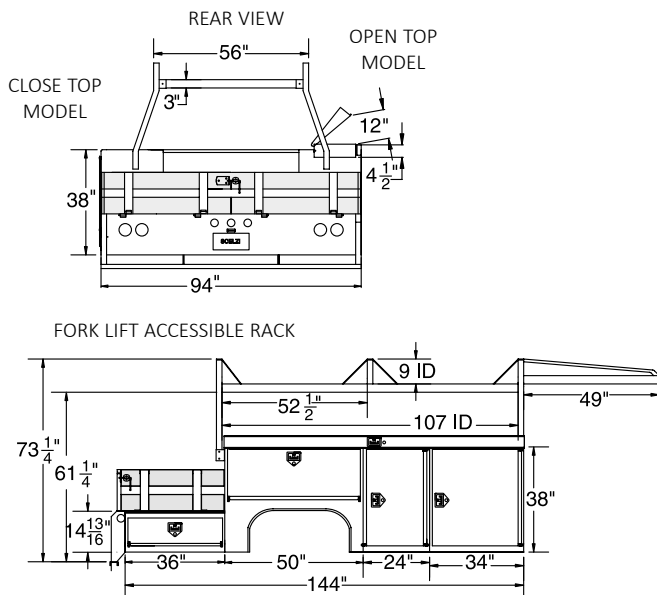

All drawings reflect dimensions for the most popular applications.

# Standard Features On All Scelzi Signature Truck Bodies



Open tops - open top lids of 16 gauge galvalneal metal with smooth tops, "Z" style hat section, using 18 gauge inner panel, with aluminum diamond plate overlay. Scelzi Enterprises has the strongest open tops in the industry. Heavy duty gas shocks 2 per open top for easy door opening. 4 1/2" deep open top tray.

Doors - double panel door 18 gauge outer, 20 gauge inner laminated together for greater durability "Z" style hat section for extra strength. Doors mounted using stainless steel hinge block with nylon insert, stainless steel self sealing mono bolt, and 5/16 stainless steel full length door shaft.



Door Seals - Special design contour - Neoprene seal inside the door.  
1/8 x 1/2 rubber stops the door from chaffing against the body.

Gas shocks on open top compartments and vertical doors.

Tailgate - heavy duty self leveling tailgate with 12 gauge diamond plate inner panel and 1/4" stainless steel end cap.

Stainless steel hinge block with nylon insert



Tailgate bracket - 10 gauge stainless steel.

Scelzi Signature Service Body Is Shown

Shelves - 16 gauge galvanized with return flange curl. Shelf brackets are 12 gauge galvanized.

Shelves are Heavy duty lock-in-place

All vertical compartments have 2 adjustable shelves, horizontal compartments have 1 adjustable shelf

Three point latching system on all compartment doors.

All shelves are adjustable on 2" centers

Tail hinges on 5/8" stainless steel Allen Head Shoulder Bolt with 5/8" Bronze Bushing.

Seal-beam type tail, clearance and back-up lights.

All bodies equipped with a six-inch step bumper. Powder coated grey.

Superior underbody construction using thicker gauge steel and more cross-members than other truck body builders

## Additional Signature Body Features:

- Six-point mounting on 8 and 9 foot bodies. Eight point mounting on 11 and 13 foot bodies.
- All beds are caulked with Ultra Neoprene sealers, and the underside of the bed and wheel wells are under-sealed before the bed is installed
- Multiple coats of primer and urethane paint are added for longest durability

Chrome Scelzi T-Bar handle latches with polished rivet-free stainless steel pockets and Galvalneal steel locking rods



Three-year bulkhead to bumper warranty

All compartment doors equipped with barrel locks



## Work Decks



94"x18" Outrigger Work Deck

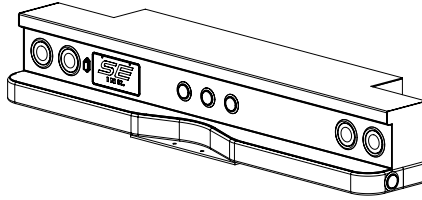

94"x18" V-Groove Outrigger Work Deck

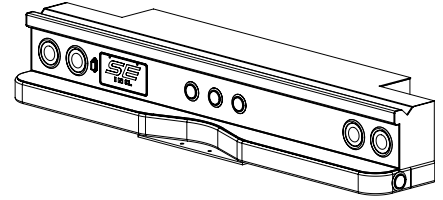

94"x24" Access Door Outrigger Work Deck

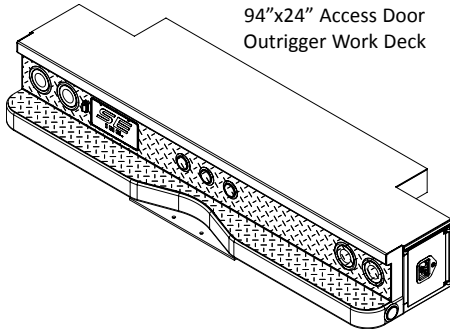

94"x18" Work Deck

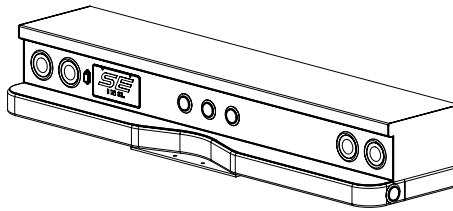

94"x18" V-Groove Work Deck

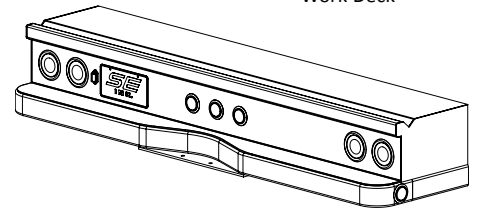

94"x18" Access Door Work Deck

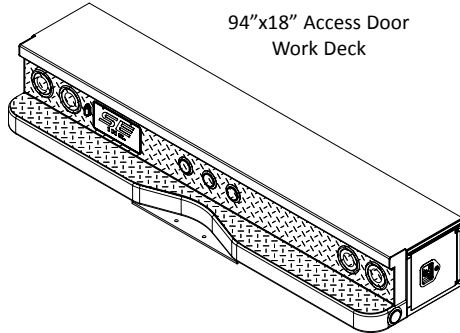

94"x18" Full Thru Access Door Work Deck

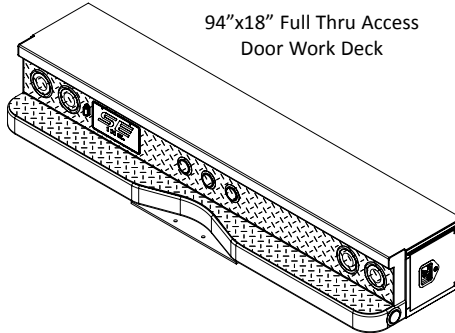

94"x18" Access Door V-Groove Work Deck

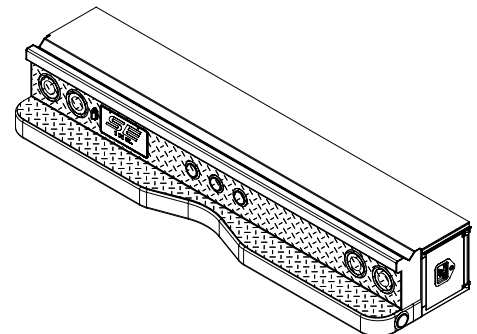

## Bumpers

DSB-15  
STRAIGHT RAIL DIAMOND  
PLATE BUMPER WITH SEAL  
BEAM LIGHTS

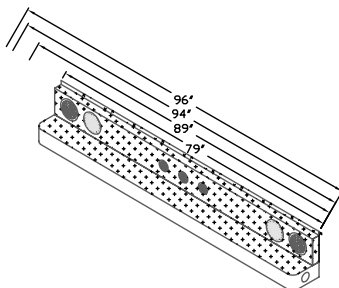

DVB-19  
V-NOTCH DIAMOND PLATE  
STEP BUMPER WITH SEAL  
BEAM LIGHTS

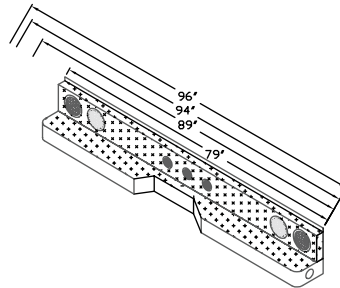

SDB-13  
DIAMOND PLATE RECESS  
STEP BUMPER WITH SEAL  
BEAM LIGHTS

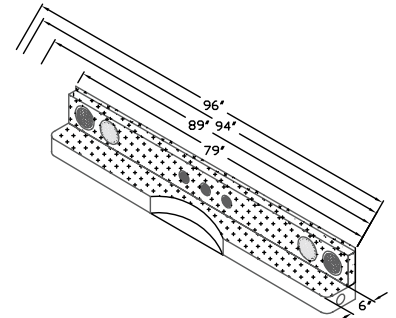

Other bumper style options available, but not shown



Photos shows SB-98-79-49-38-VO with 38" high compartments

Photos may contain optional equipment - verify your specifications when you order.

## SINGLE REAR WHEEL Standard Specifications

Body Dimensions Available:	SB-80	80 inches Long x 79 inches Wide	40 CA
	SB-98	98 inches Long x 79 inches Wide	56 CA
	SB-108	108 inches Long x 79 inches Wide	60 CA

Compartment Height: 38 inches high is standard  
Options: 33 and 43 inch high compartments are available as a special order.

Rear Wheel: Single

Color: White

Storage Compartments: Aluminum diamond plate on top  
See page 27 for tool box configuration options

Optional Top Rack: Powder coated over the cab contour material rack

Style	Orientation	Tops
VO	Vertical	Open
HO	Horizontal	Open
V	Vertical	Closed
H	Horizontal	Closed

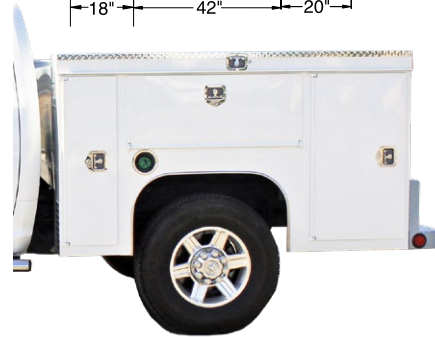
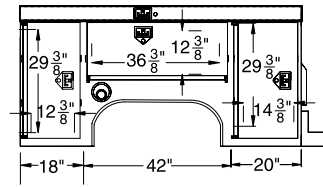
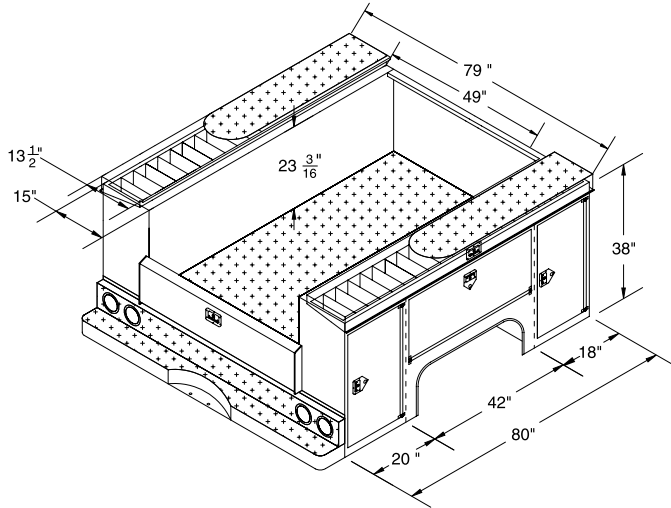

Photo shows SB-108-79-49-38-VO with 38" high compartments

# SIGNATURE SERVICE Bodies



## SB-80 Most Common Dimensions (SB-80-79-49-38-V0)



## SB-98 Most Common Dimensions (SB-98-79-49-38-V0)

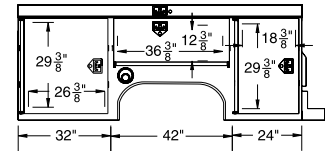
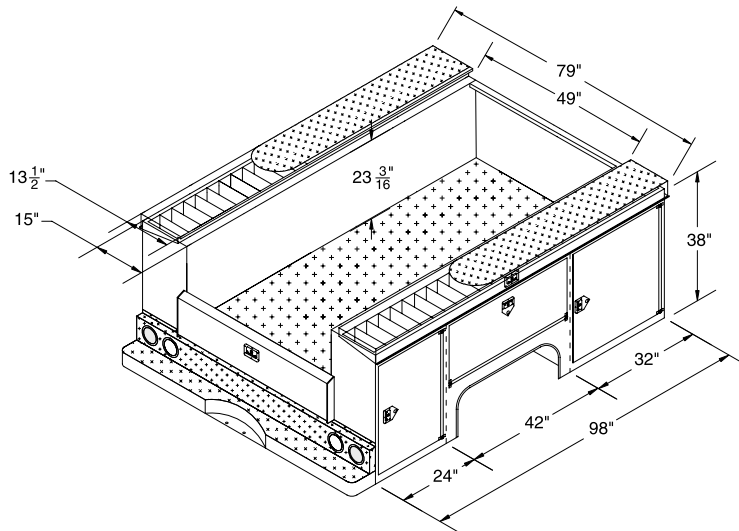

## SB-108 Most Common Dimensions (SB-108-79-49-38-V0)

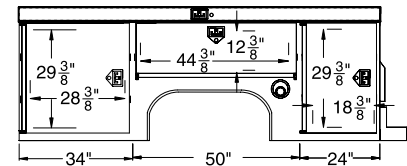
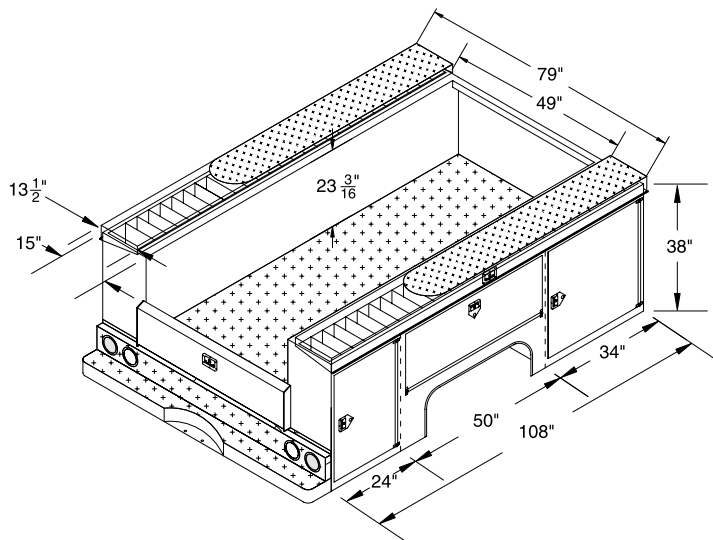

# SIGNATURE SERVICE Bodies - DUAL



Photo shows  
SBD-108-94-49-38-V  
with 38" high compartments

Photo shows  
SBD-108-96-51-38-VO  
with 38" high compartments  
and optional work deck

Photos may contain optional equipment - verify your specifications when you order.

## DUAL REAR WHEEL

## Standard Specifications

Body Dimensions Available:	SBD-98	98 inches Long x 96 inches Wide	56 CA
	SBD-108	108 inches Long x 94 inches Wide	60 CA
	SBD-132	132 inches Long x 94 inches Wide	84 CA
	SBD-156	156 inches Long x 94 inches Wide	108 CA

Compartment Height: 38 inches high is standard  
Options: 33 and 43 inch high compartments are available as a special order.

Rear Wheel: Dual

Color: White

Storage Compartments: Aluminum diamond plate on top  
See page 27 for tool box configuration options

Optional Top Rack: Powder coated over the cab contour material rack

Style	Orientation	Tops
VO	Vertical	Open
HO	Horizontal	Open
V	Vertical	Closed
H	Horizontal	Closed

## SBD-98 Most Common Dimensions (SBD-98-96-51-38-VO)

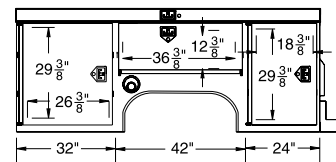
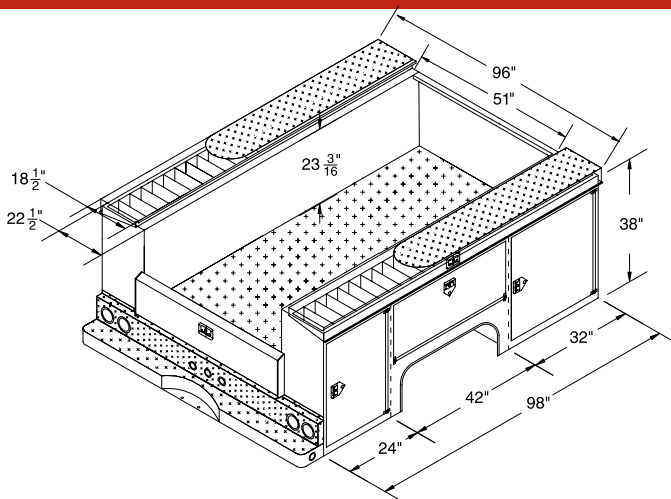

# SIGNATURE SERVICE Bodies - DUAL



## SBD-108 Most Common Dimensions (SBD-108-94-49-38-VO)

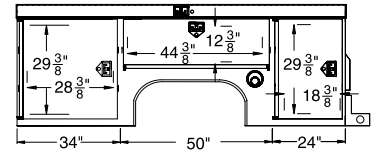
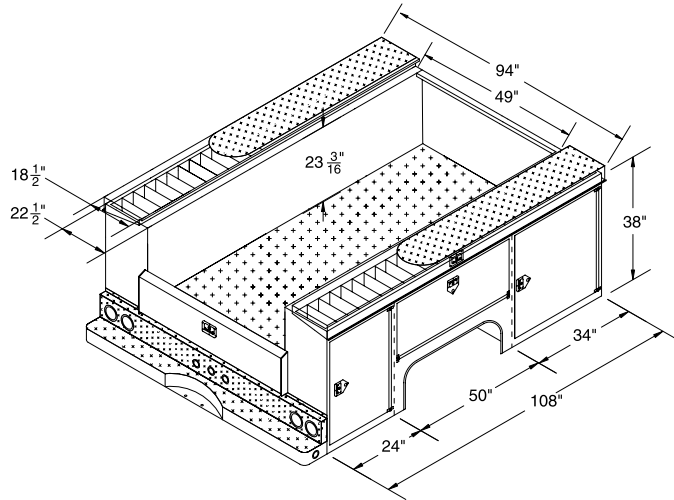

## SBD-132 Most Common Dimensions (SBD-132-94-49-38-VO)

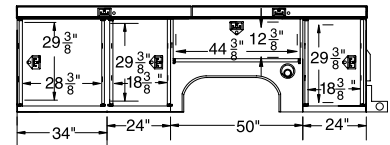
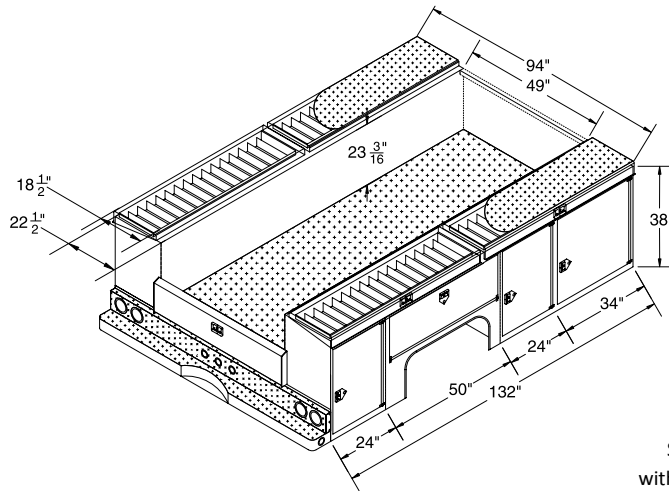
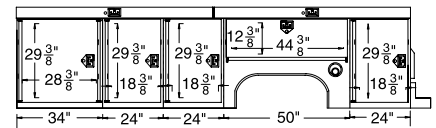
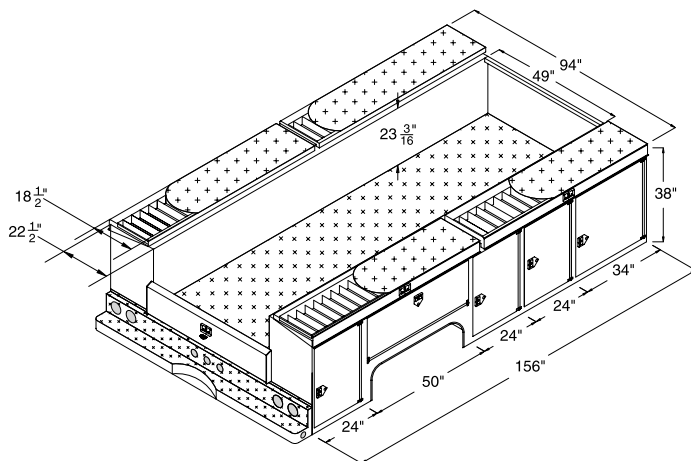

Photo shows SBD-132-94-49-38-VO with 38" high compartments

## SBD-156 Most Common Dimensions (SBD-156-94-49-38-VO)



With optional work desk and "V" Groove

# CROWN SERIES SERVICE Bodies



Photo shows  
SBCR-98-79-49-38-VO

Photo shows  
SBCR-108-79-49-38-VO

Photos may contain optional equipment - verify your specifications when you order.

## SINGLE REAR WHEEL Standard Specifications

Body Dimensions Available:	SBCR-98	98 inches Long x 79 inches Wide	56 CA
	SBCR-108	108 inches Long x 79 inches Wide	60 CA

- Compartment Height: 38 inches high only
- Rear Wheel: Single
- Color: White
- Storage Compartments: Aluminum diamond plate on top
- Optional Top Rack: Powder coated over the cab contour material rack

Style	Orientation	Tops
VO	Vertical	Open
HO	Horizontal	Open
V	Vertical	Closed
H	Horizontal	Closed

### SBCR-98 (SBCR-98-79-49-38-VO)

### SBCR-108 (SBCR-108-79-49-38-VO)

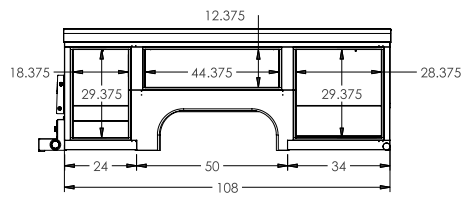
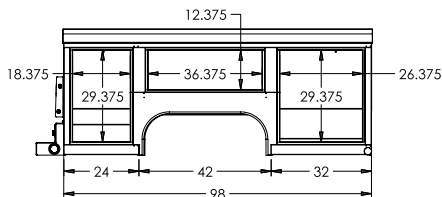
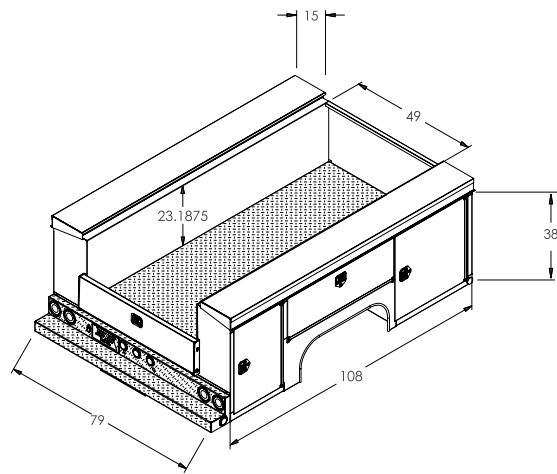
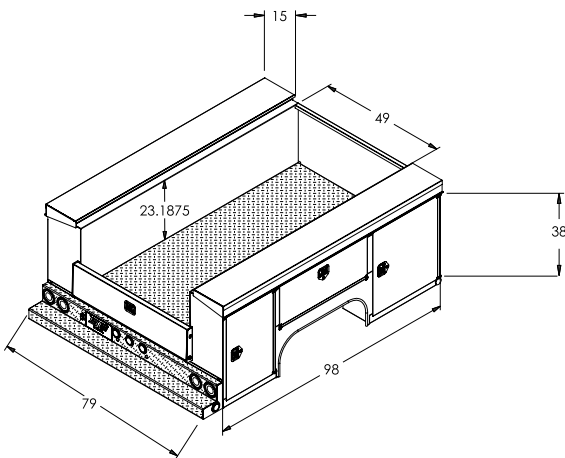



# CROWN SERIES SERVICE Bodies - DUAL



Photo shows  
SBDCR-132-94-49-38-VO

Photo shows  
SBDCR-108-94-49-38-VO

Photos may contain optional equipment - verify your specifications when you order.

## DUAL REAR WHEEL

## Standard Specifications

Body Dimensions Available:

SBDCR-108 108 inches Long x 94 inches Wide

60 CA

SBDCR-132 132 inches Long x 94 inches Wide

84 CA

Compartment Height: 38 inches high only

Rear Wheel: Dual

Color: White

Storage Compartments: Aluminum diamond plate on top (optional)

Optional Top Rack: Powder coated over the cab contour material rack

Style	Orientation	Tops
VO	Vertical	Open
HO	Horizontal	Open
V	Vertical	Closed
H	Horizontal	Closed

### SBDCR-108 (SBDCR-108-94-49-38-VO)

### SBDCR-132 (SBDCR-132-94-49-38-VO)

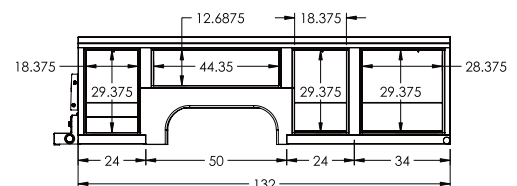
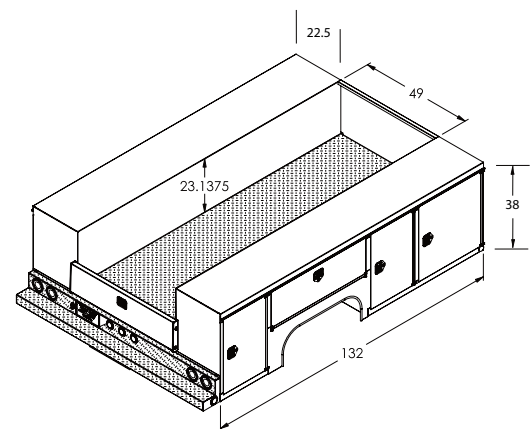
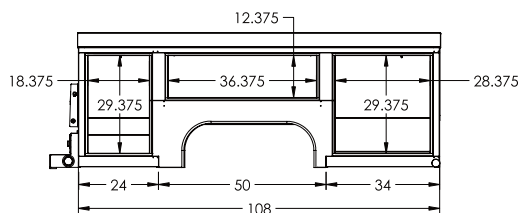
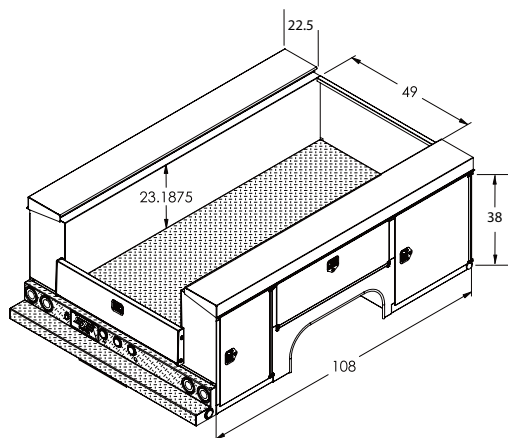



Photos may contain optional equipment - verify your specifications when you order.

## Service Body Custom Dump Insert 2 cubic yard capacity

Body Dimensions:

**SB-98-79-49-38**  
**SB-108-79-49-38**

Length = 99.5 inches      56 CA  
 Length=109.5 inches      60 CA

Style	Orientation	Tops
VO	Vertical	Open
V	Vertical	Closed

**For All Bodies**

- 44" Wide Inside x 21" Sides x 22" Tail Gate x 21" Bulkhead
- 12 Ga. Steel Throughout
- 21" Bulkhead
- 22" Double Acting Tailgate with formed brace
- 3 Flange Top Rail
- Beveled Floor Corners at sides
- 4" channel crossmembers
- 5" Long Sills
- Pinned Tailgate Locks



Color: White is standard

Hoist: Scelzi CS412T-11 electronic over hydraulic single acting hoist  
 4.1 ton capacity  
 Full steel sub-frame integrated into service body understructure  
 Double acting, Power Up/Down  
 LED Body Raised Warning Light  
 Inside Cab Control

Dimensions for  
 SB-98-79-49-38-VO  
 2 CUBIC YARD DUMP INSERT

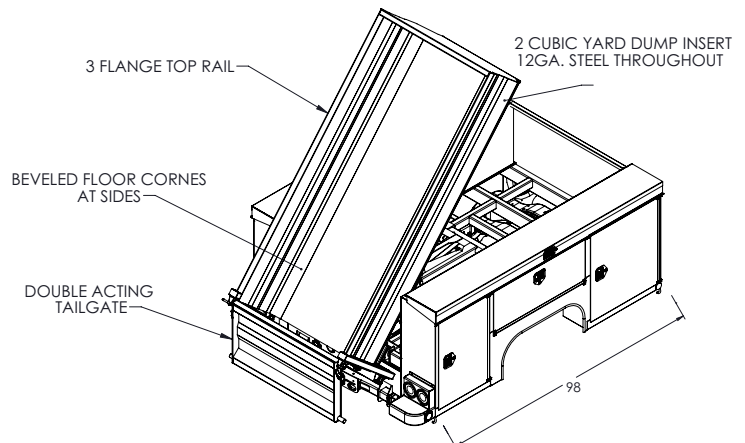
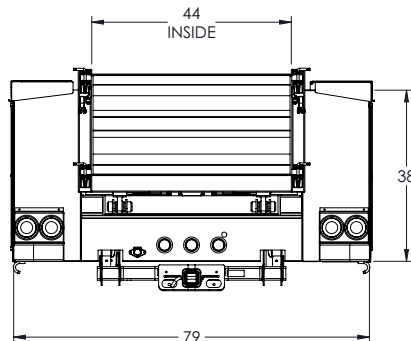

# Crane and Signature Service Body Configuration Options

Dimensions shown represent 43" tall body with 22-1/2" wide compartments. Optional 20" wide compartments available.

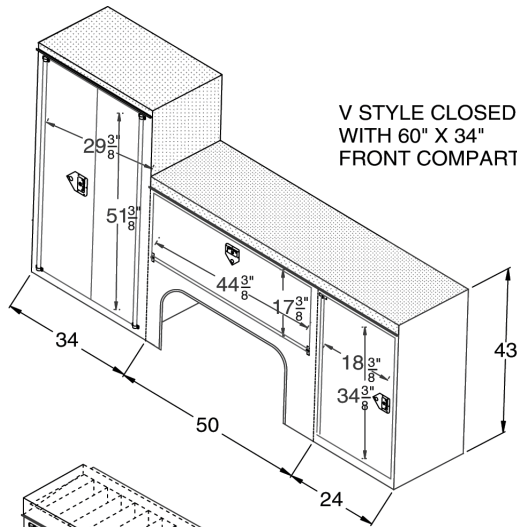

V STYLE CLOSED STYLE  
WITH 60" X 34"  
FRONT COMPARTMENT

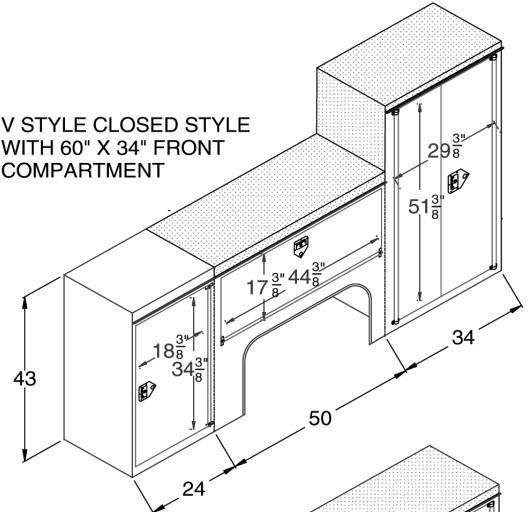

V STYLE CLOSED STYLE  
WITH 60" X 34" FRONT  
COMPARTMENT

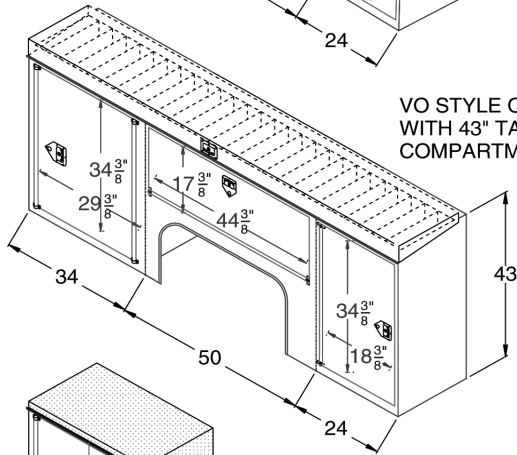

VO STYLE OPEN TOP  
WITH 43" TALL  
COMPARTMENT

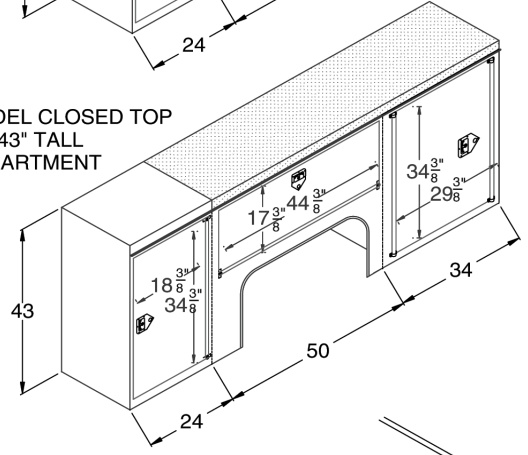

V MODEL CLOSED TOP  
WITH 43" TALL  
COMPARTMENT

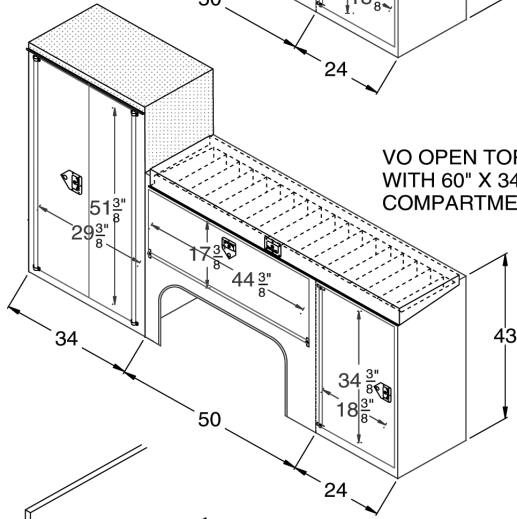

VO OPEN TOP STYLE  
WITH 60" X 34" TALL  
COMPARTMENT

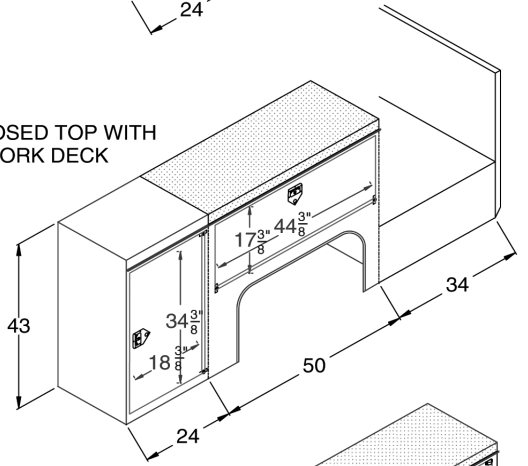

V CLOSED TOP WITH  
34" WORK DECK

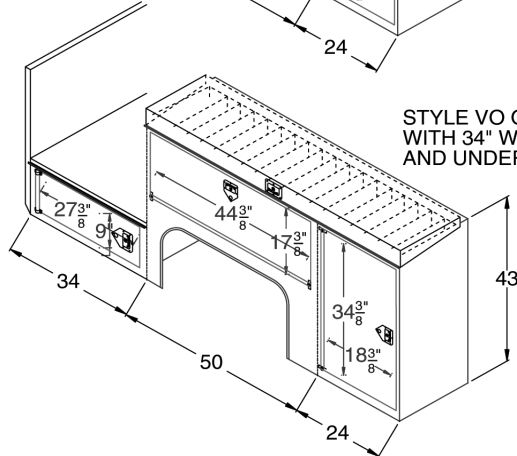

STYLE VO OPEN TOP  
WITH 34" WORK DECK  
AND UNDER BODY BOX

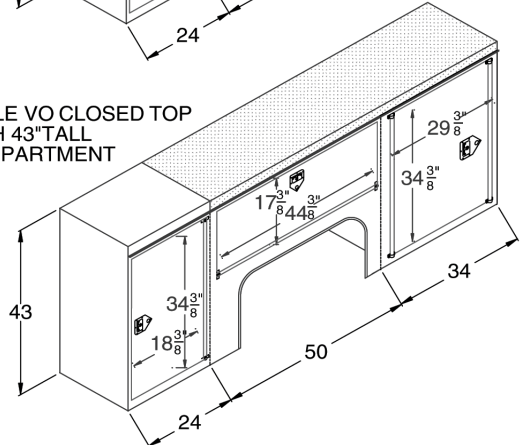

STYLE VO CLOSED TOP  
WITH 43" TALL  
COMPARTMENT

# Crane and Signature Service Body Configuration Options

Dimensions shown represent 43" tall body with 22-1/2" wide compartments. Optional 20" wide compartments available.

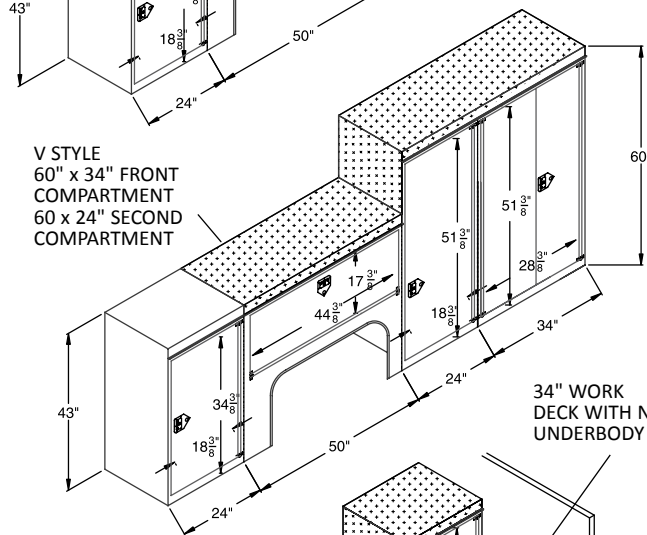
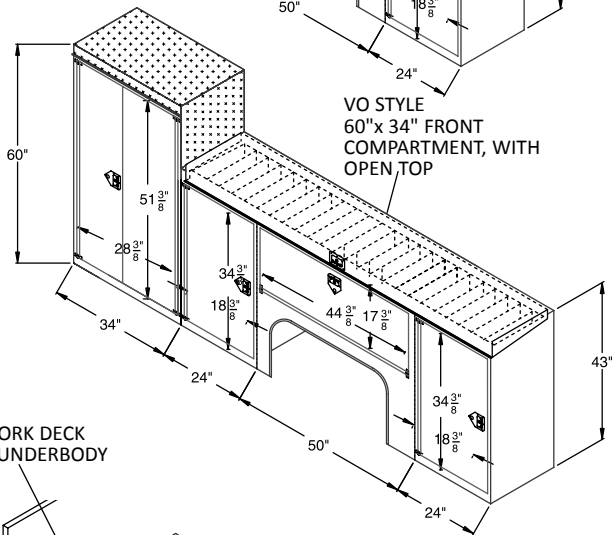
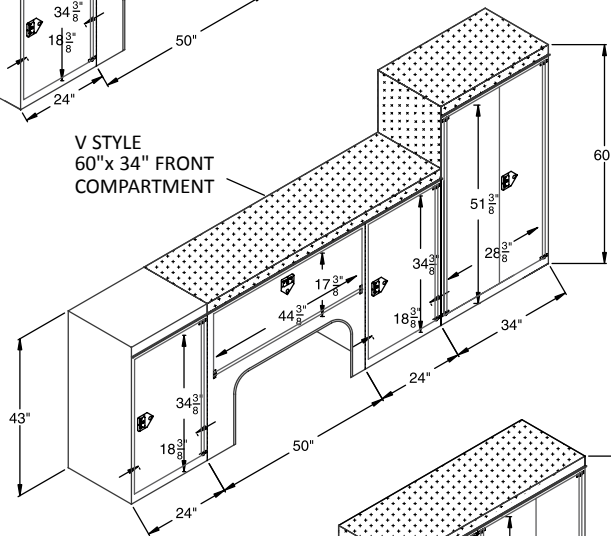
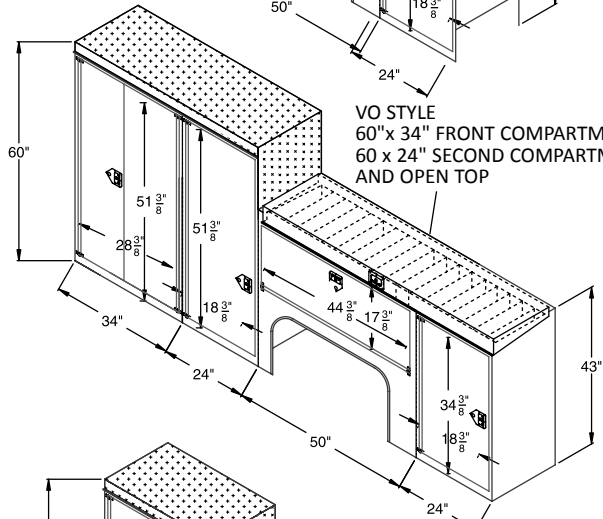
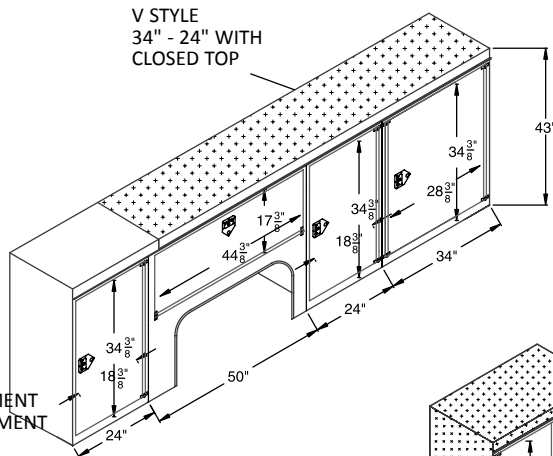
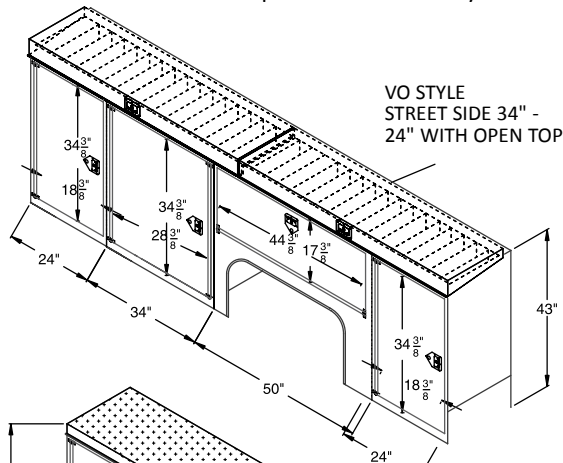

34" WORK DECK  
WITH UNDERBODY  
BOX

34" WORK  
DECK WITH NO  
UNDERBODY BOX

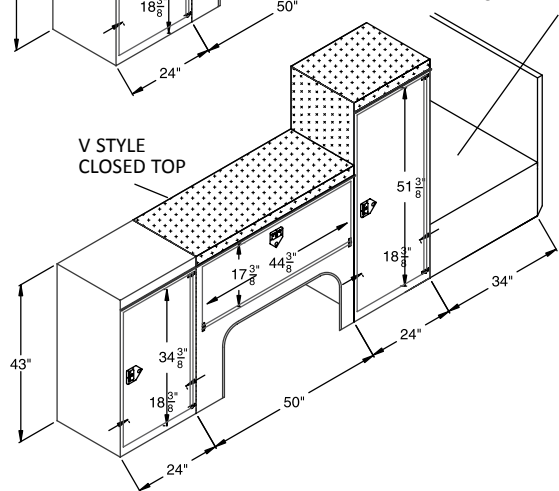
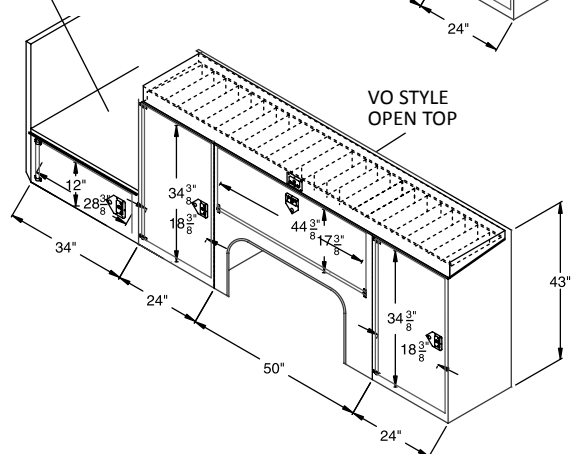

# Crane and Signature Service Body Configuration Options

Dimensions shown represent 43" tall body with 22-1/2" wide compartments. Optional 20" wide compartments available.

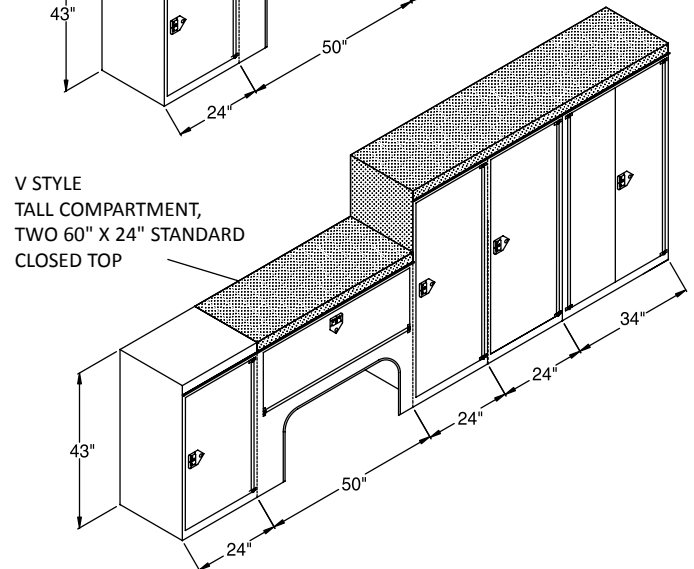
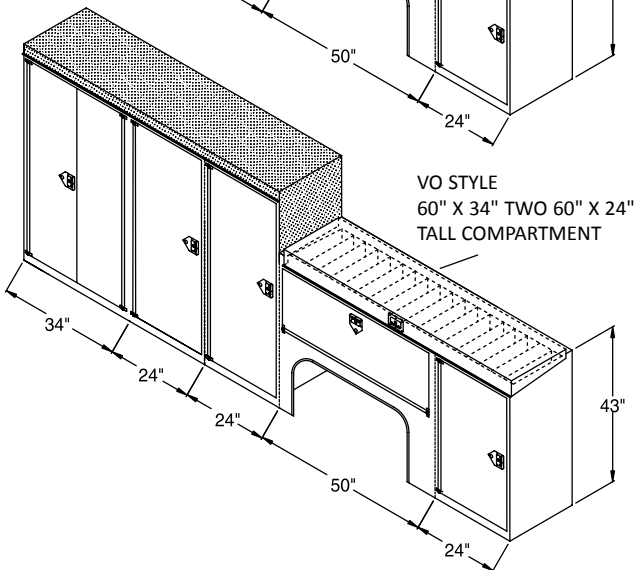
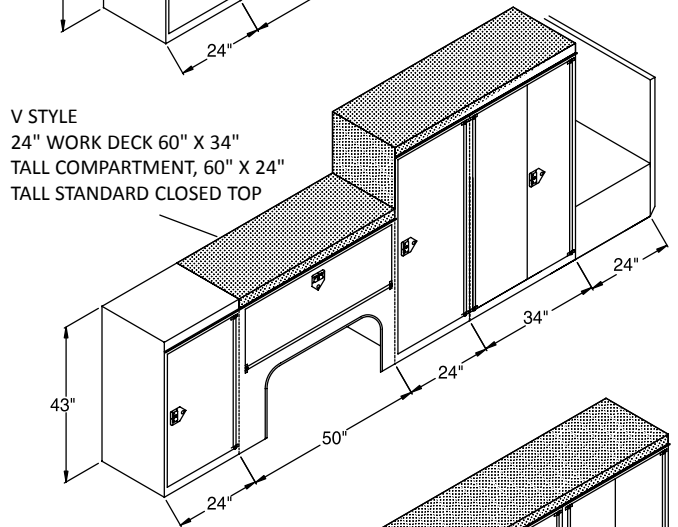
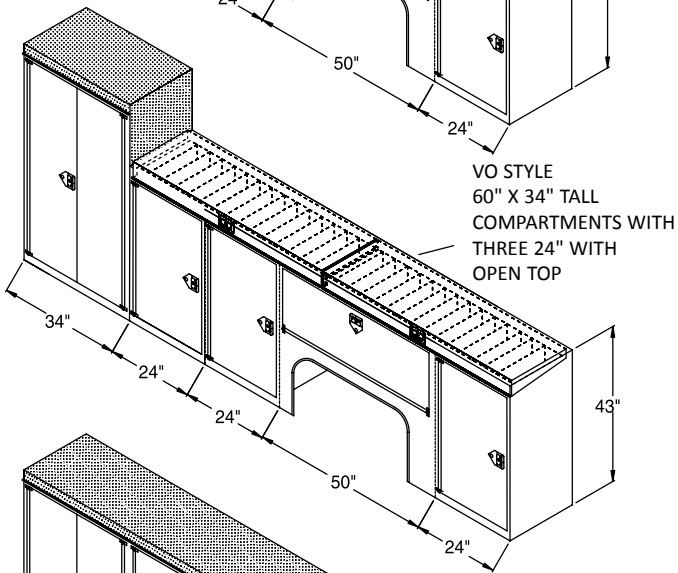
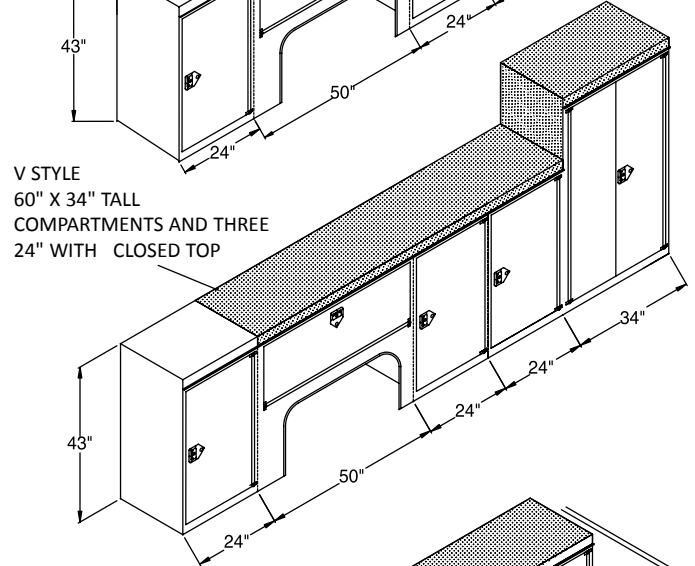
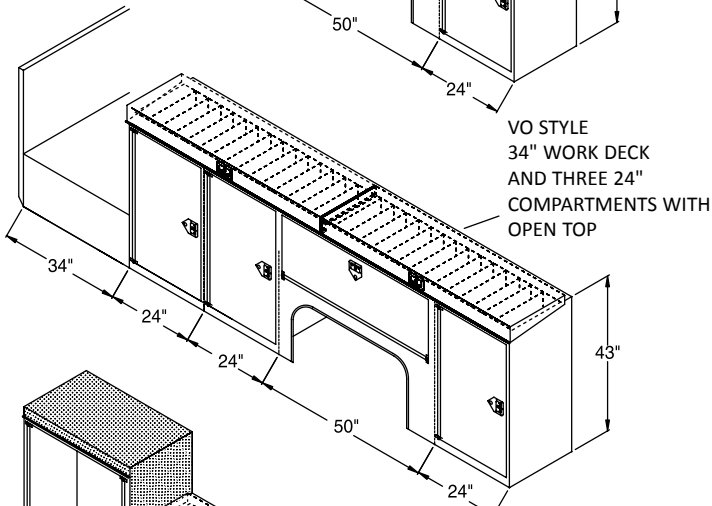
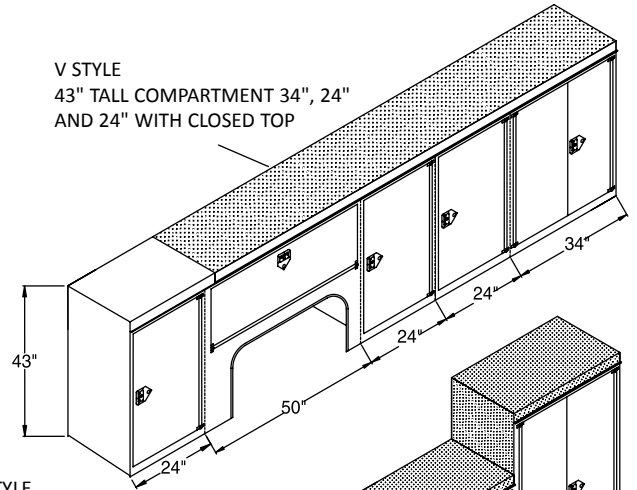
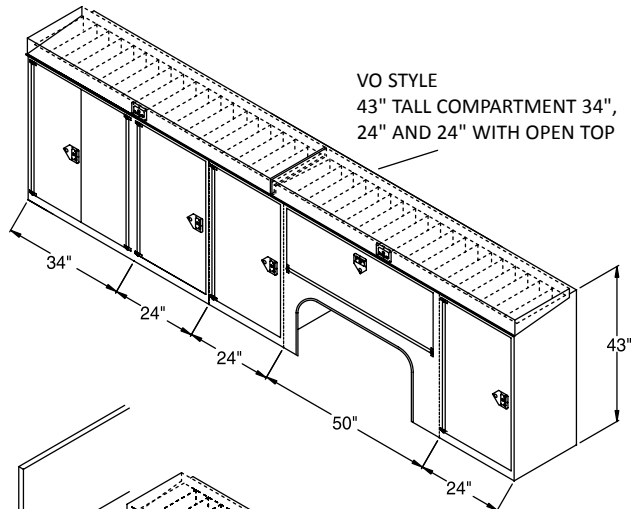



Photo shows SBD-108-94-49-43-V with 43" high compartments

Photo shows SBD-132-94-49-38-VO with 38" high compartments, raised roller top and barn doors with custom lighting

Photos may contain optional equipment - verify your specifications when you order.

## Super Structures for 8600 GVW\* and higher Standard Specifications

**GVW \*** is Gross Vehicle Weight Rating, also known as Gross Vehicle Mass (GVM). This is the maximum operating weight of a vehicle chassis as specified by the manufacturer.

**Body Dimensions:** Lengths available in 98, 108, 132 and 156 inches only. Can be ordered with tapered sides. Scelzi 6" recessed rear bumper and standard service body compartment options (see pages 27-29) Compartment height options are shown below.

**Window Options:** 1 front window 12" high X 28" wide. Windows in rear doors 18" X 12" wide

**Color:** White or black

Body Height	SUPER STRUCTURE HEIGHT		
	24 inches	36 inches	48 inches
33"	42-3/16"	54-3/16"	66-3/16"
38"	47-3/16"	59-3/16"	71-3/16"
43"	52-3/16"	64-3/16"	76-3/16"

Dimensions are measured from the floor to the inside structure

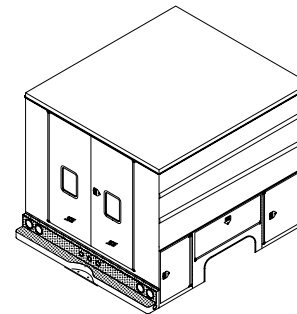
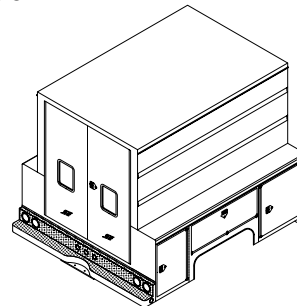

Rollertops are optional - see page 52 for more rollertop options on Service Bodies



Photo shows optional diamond plate panel and hose





**WCB-8000**

**132" Long**

**Standard Specifications**

Body Dimensions: 132 inches Long x 96 inches wide, with capacity for 5,000-8000 lb crane.

Color: White

Storage Compartments: Compartment height is 43"

OPTIONS:

60" Tall Oxy-Acetylene Front Compartment (shown in photos above)

24" or 34" Compartment 60" High with 3 Standard Adjustable Shelves

18" to 24" Rear Work Deck – Set up for Outriggers with or without Access Doors

Rear Work Deck with Through Compartment

"Top 5" Only"

Work Deck with "V" Groove

V-Notch Bumper

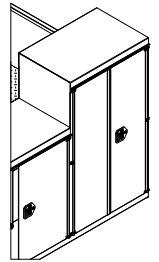

CRANE BODIES ARE ALSO AVAILABLE WITH OPTIONAL 60" TALL FRONT COMPARTMENTS

Dimensions shown are for WCB-132-96-56-43-V

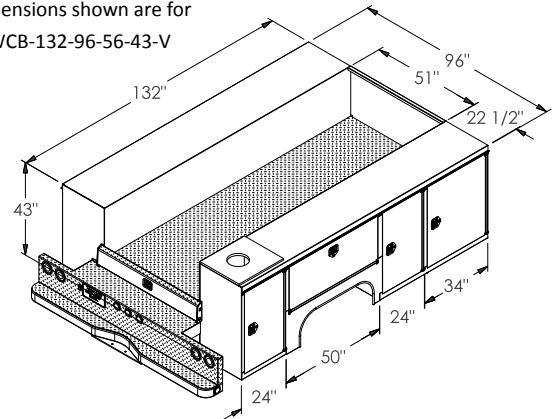

Style	Orientation	Tops
VO*	Vertical	Open
V	Vertical	Closed
* Only available on non-crane side		

Western Crane Body packages are available

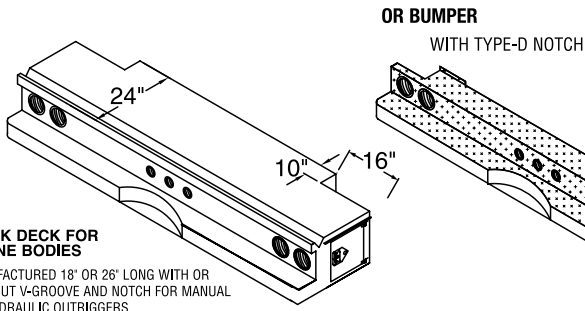

**WORK DECK FOR CRANE BODIES**  
MANUFACTURED 18" OR 26" LONG WITH OR WITHOUT V-GROOVE AND NOTCH FOR MANUAL OR HYDRAULIC OUTRIGGERS

CRANE BODY UNDERSTRUCTURE AND REINFORCEMENT

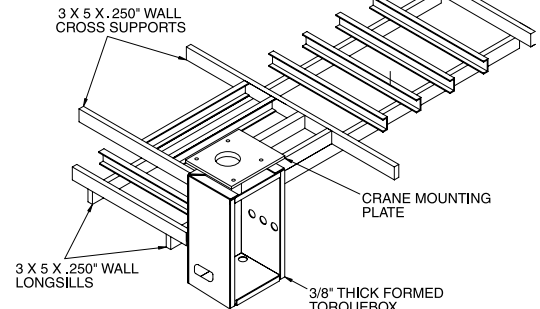

# WELDER BODY



Photo shows  
SBD-108-94-49-33-VO  
with optional Polyurea lining



Photo shows  
Custom Order 132" long  
SBD-132-94-49-33-VO  
with custom double front  
compartments



Photos may contain optional equipment - verify your specifications when you order.

## SBD-108-94-49      108" Long      60 CA      Standard Specifications

**Body Dimensions:** 108 inches Long x 94 inches wide. Compartment height is 33 inches.  
Custom Order Only: 132 inch Long body, as shown in photo above.

**Rear Wheel:** Dual

**Color:** White

**Storage Compartments:** Tapered Front Compartments and Smooth Steel Floor with a 5" Drop  
Oxygen Bottle Holders in Transverse Compartment - Driverside  
Acetylene Bottle Holders in Upright Position in Front Compartment - Driverside  
Hose Holder in Front Compartment - Driverside  
Oxygen and Acetylene Hose Reel with Louver in Lower Bottom of Front Compartment - Driverside  
Adjustable Shelves in Front Compartment - Curbside  
Horizontal Compartment with Dividers  
Rear Work Deck with Access Doors and "V" Groove  
Perforated Rear Step Bumper  
Class 5 Receiver Hitch Without Insert  
Trailer Plug 7/4 Way OEM Socket

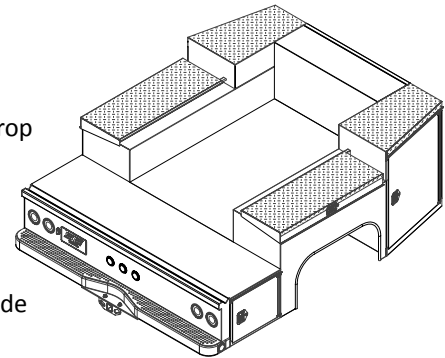

Dimensions shown are for  
SBD-108-94-49-33-V

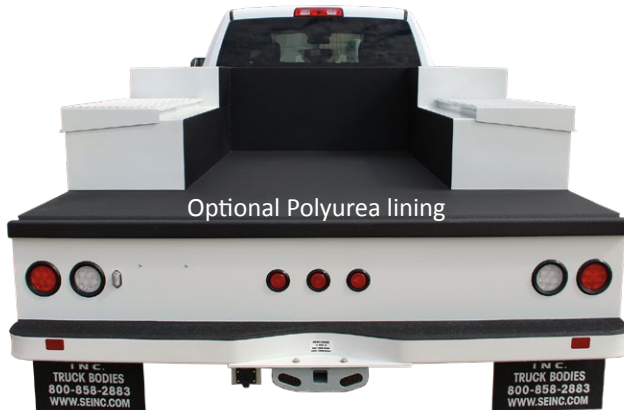
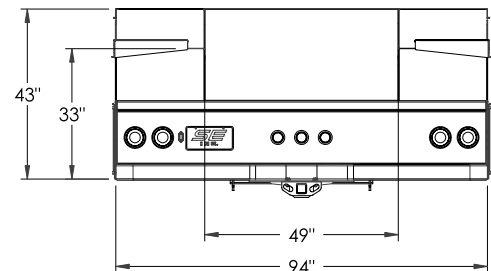
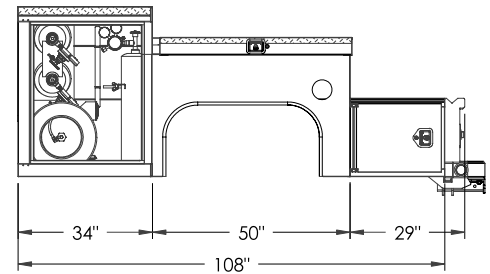

All drawings reflect dimensions for the most popular applications.





Photos may contain optional equipment - verify your specifications when you order.

## Hoist Specifications - Smaller Dump Sizes

The Scelzi line of durable, single stage scissor hoists:

- Range in capacity from 11.2 to 22.5 ton
- Fit bodies from 8 to 20 feet long
- Black powder-coated in a durable, rust-resistant finish
- In-Cab Dash-mounted LED "Hoist Up" Safety Light
- Internally/externally accessed Push Button Hoist Up-Down Controller
- Dual, Manual-control Hoist Secure Locking Arms
- Power Take Off (PTO) for most models
- Scelzi CS515T and CS615T-11 are electric/hydraulic
- 3-year Scelzi Warranty

### Scelzi Hoists Standard Sizes

Body	Model	Tons
12' Chipper	CS615T-11	11.2
14' Chipper	CS620HD	11.5
16' Chipper	CS628	15.1
2-3 Yd Dump	CS615T-11	12.6
3-4 Yd Dump	CS615T-11	11.2
5-7 Yd Dump	CS820DA	22.5
6-8 Yd Dump	CS6620	22.9
7-9 Yd Dump	CS6620	22.9
10-12 Yd Dump	820DA	22.5
8'6" Landscaper	CS615T-11	12.6
10' Landscaper	CS615T-11	11.2
12' Landscaper	CS615T-11	11.2
14' Landscaper	CS615T-11	9.2

Actual hoist specifications may vary



Dash-mounted LED "Hoist Up" Safety Light and Push Button Hoist Up-Down Controller



Dual manual-control Hoist Secure Locking Arms

# DUMP BODIES



Photos may contain optional equipment - verify your specifications when you order.

## 3-4 Cubic Yards      11.6 Ft Long      84 CA      Standard Specifications

Capacity: Recommended: 14,000 - 19,000 GVW      Approx. 2,250 lbs.

Body Dimensions: Traditional rectangular body with cross-members  
 11'6" Long x 86" Wide Inside x 13" Sides x 20" Tail Gate x 32" Bulkhead  
 DBS 11-6 Dump body with solid sides is standard  
 10 Gauge High-Tensile Throughout  
 3" Cross Bars on 15" Centers x 5" Channel Longs  
 1/4 Size Cab Shield  
 Deluxe LED Light Package with Oval Stop and Turn Lights  
 Mud flaps and brackets

Color: Black or white

Hoist: Scelzi CS615T-11 (Class 40)  
 11.2 ton capacity with 12" overhang, full steel sub-frame  
 Power up and power down with LED raised up warning light  
 LED body raised warning light, inside cab control  
 See pg 33 for more hoist information

Options: Fold Down Sides (DBF 11-6 Option)  
 Semi automatic pull tarp, black mesh  
 6" x 3/16" spreader apron  
 Center ditch gate, sliding type  
 3/16" floor in lieu of 10 gauge  
 LED lighting

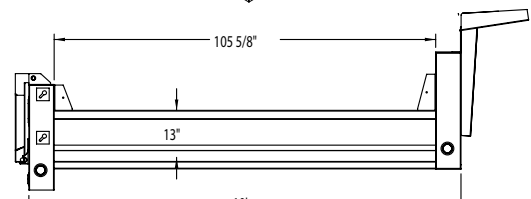
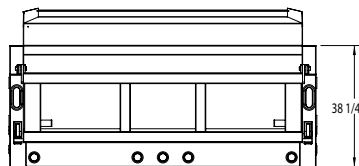
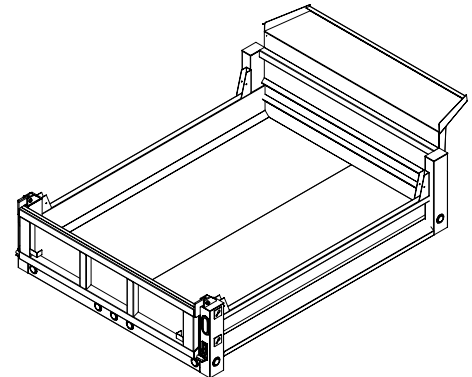
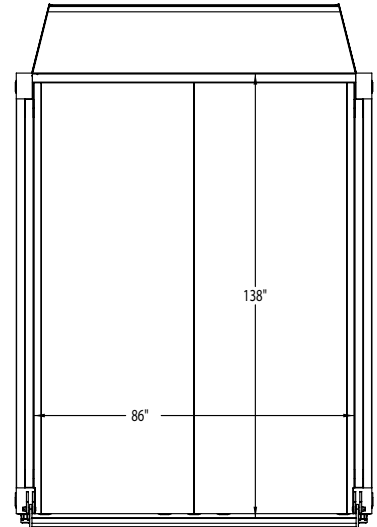

NOTE: 13" DIMENSION IS FROM FLOOR TO TOP OF SIDE RAIL

# DUMP BODIES



Photos may contain optional equipment - verify your specifications when you order.

## 5-7 Cubic Yards      10 Ft Long      Standard Specifications

Capacity: Recommended: 26,000 -33,000 GVW      Approx 3,400 lbs.

Body Dimensions: Traditional rectangular body with cross-members  
 10' Long x 86" Wide Inside x 24" Sides x 32" Tail Gate x 36-40" Bulkhead  
 10 Gauge High-Tensile Steel Sides and Ends  
 3/16" High-Tensile Steel Floor with Beveled Side Corners  
 Sloped Running Boards  
 6" Channel Longs x 3" Channel Cross Bars on 15" Centers  
 Double Acting Tail Gate (Manual Trip Lever), 6-Panel  
 1/4 Cab Shield, Full Depth Rear Corner Post  
 4-Flange Boxed Top Rail, Double  
 Wall Sides with Center Corrugation, Spreader Apron  
 Deluxe LED Light Package with Oval Stop and Turn Lights in Rear Corner Post,  
 Recessed Side Clearance Lights, and Set of Mud Flaps

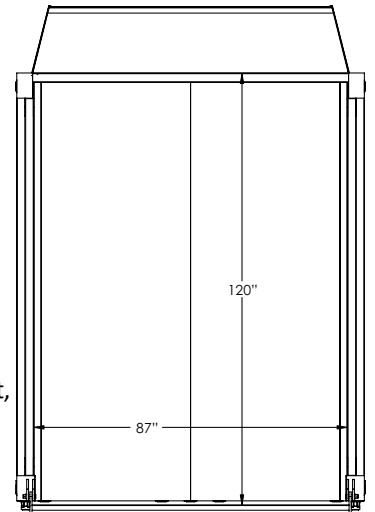

Color: Black or White

Hoist: Scelzi 820DA with sub-frame (Class 60)  
 22.5 ton capacity with 12" overhang  
 Power up and power down with LED raised up warning light  
 LED body raised warning light, inside cab control  
 See pg 33 for more hoist information

Options: Ditch Gate in Tailgate  
 Semi automatic pull tarp, black mesh  
 3/16" High-Tensile Tailgate  
 Air Operated Tailgate Locks  
 Air Shift PTO or Hot Shift PTO - for Allison Transmission  
 580 Premier Pintle Hitch or Plug  
 Pull Trap, and Toolbox

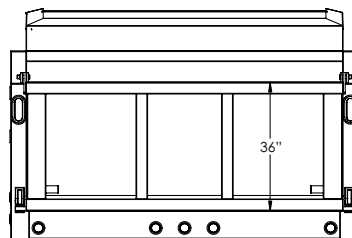
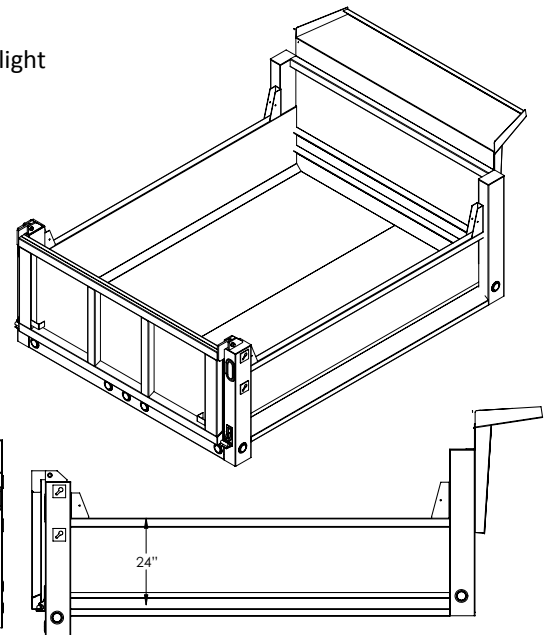



Photos may contain optional equipment - verify your specifications when you order.

## 10-12 Cubic Yards      14 Ft Long      Standard Specifications

- Capacity:** Recommended: 33,000 GVW
- Body Dimensions:** Traditional rectangular body with cross-members  
 10 GA. High-Tensile Steel Throughout  
 3" Channel Crossbars on 15" Centers  
 Headboard with Corrugations 10" Higher Than Sides  
 Manual Tailgate Lever or Air Cylinder Set-Up  
 (Air Cylinder not Included)  
 5", 6", or 7" Longsills  
 Tailgate 6" Higher Than Sides  
 Beveled Floor Corners  
 Full Depth Rear Corner Posts  
 Two-Panel Tailgate  
 Boxed Top Rails and Horizontal Side Braces
- Color:** Black or White
- Hoist:** Scelzi C63120T  
 22.5 ton capacity with 12" overhang  
 Power up and power down with LED raised up warning light  
 See pg 33 for hoist details
- Options:** Air Tailgate Control  
 Air Dump Control  
 3/16" Spreader Apron  
 Ditch Gates  
 Oval Stop and Turn Lights  
 Front Corner Post  
 Nested Crossbars  
 Double Wall Sides with Center Horizontal Brace Length of Body  
 Concave sides  
 Hoist Stabilizer  
 Guards in End Post for Turn Signal Lights  
 Hydraulic Wet Line for Pop Trailer  
 Electrically Activated PTO for Manual Transmission  
 Air Pintle Hitch  
 Semi automatic pull tarp, black mesh (as shown at right)

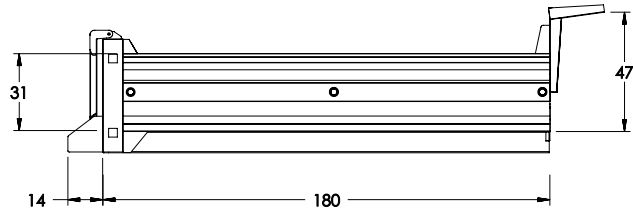
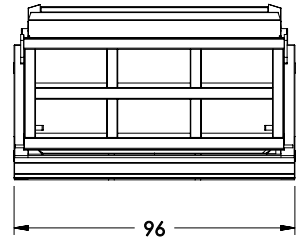
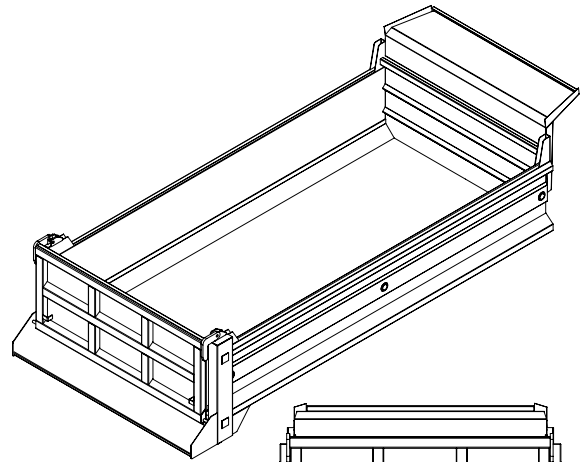

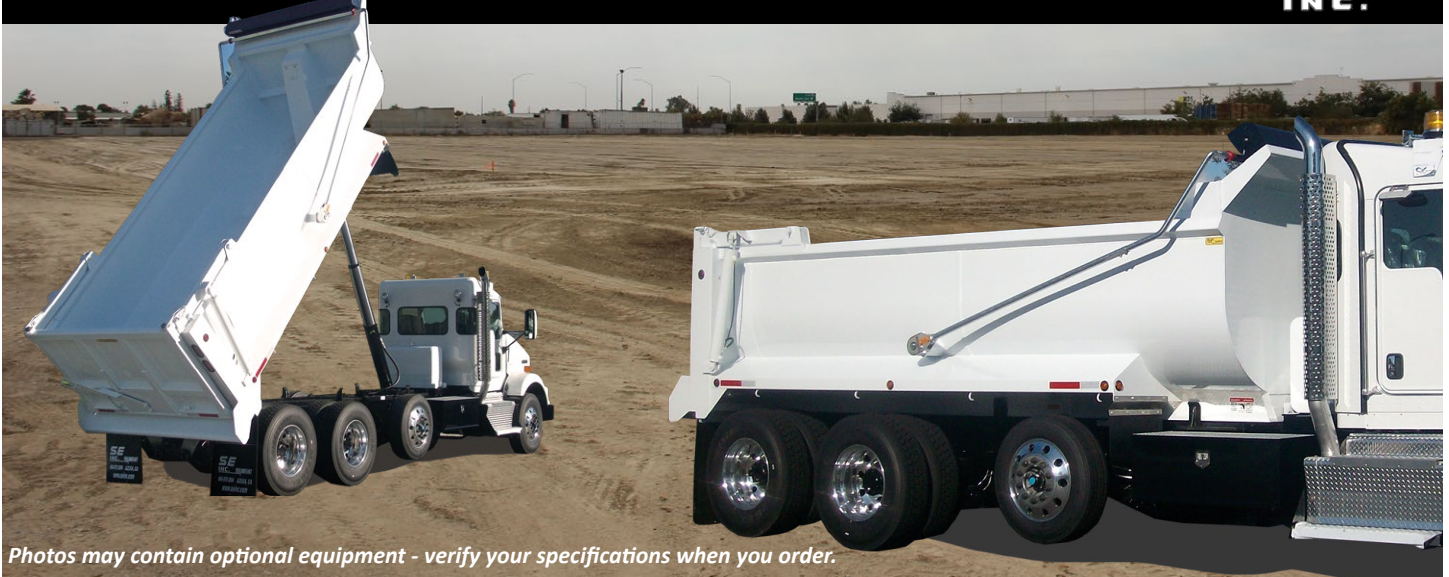

Photos may contain optional equipment - verify your specifications when you order.

## Semi-Elliptical Dump Bodies      Various Lengths      Standard Specifications

**Capacity:** Varies from 6-18 cubic yards in lengths from 10 to 19 feet long

**Body Dimensions:** Semi-elliptical curved body design  
 4 x 4 x 1/4 Tubing Top Rail Diamond Up Inside Vertical Stiffener  
 10 Gauge High-Tensile Fenders Starting Approx. 30" from Front  
 Fenders are Full Boxes Closed Bottom Side, 100% Welded  
 All Heavy Duty Hardware Top & Bottom on Tailgate  
 3 Panel Tailgate or 6 Panel Tailgate  
 Air Operated Lower Tailgate Locks  
 1/4 Size Cab Shield or Wing Type  
 8" x 3/16" Spreader Apron  
 Deluxe Light Kit Oval Stop & Turn

**Color:** Black or White

**Hoist:** Model varies by capacity  
 Power up and power down  
 LED raised up warning light

**Options:** Air Lift Tailgate Cyl. Inside Rear Post (No Door)  
 Doors on Rear Corner Post for Air Cyl Access  
 Ditch Gate Center  
 Trap (Manual or Electric)  
 Air Hitch 370 Premier and Electric Plug  
 2 - 22.5 x 8.25 Alcor Uni-Mt F/R Polished 10 Hole Wheels  
 2 - 255/70 R22.5 Sumitomo S+727 16 Ply Tires  
 Reverse Mounting Model for Clearance on Tanks ECT

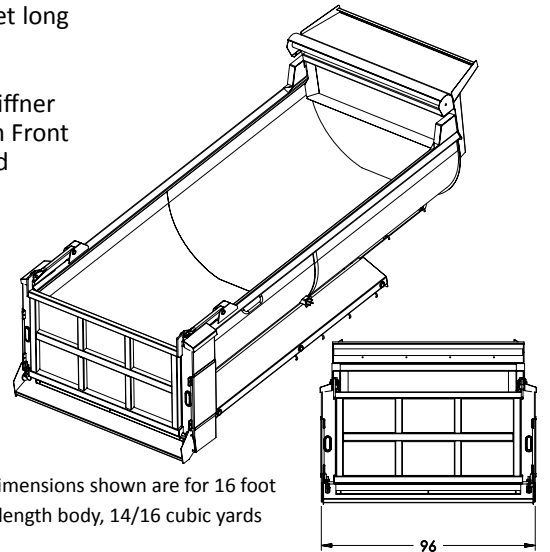

Dimensions shown are for 16 foot length body, 14/16 cubic yards

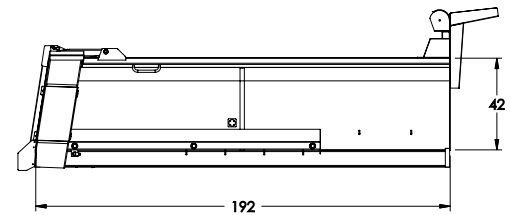

**Custom Dump Bodies:** Other Custom Dump Bodies Available as a Special Order - Contact Us



# CHIPPER BODIES



Photos show custom light packages and toolboxes available

Photos may contain optional equipment - verify your specifications when you order.

**12 Foot Chipper and Hoist**

**84 CA**

**11.2 ton hoist**



Optional vents are shown

Photos may contain optional equipment - verify your specifications when you order.

**14 Foot Chipper and Hoist**

**120 CA**

**15.2 ton hoist**



Photos may contain optional equipment - verify your specifications when you order.

**16 Foot Chipper and Hoist**

**138 CA**

**17.6 ton hoist**



*Optional lighting and toolbox configurations are available*



## Chipper and Hoist

## Standard Specifications

<b>Body Dimensions Available:</b>	<b>12 ft Long x 88 inches Wide</b>	<b>84 CA</b>
	<b>14 ft Long x 88 inches Wide</b>	<b>120 CA</b>
	<b>16 ft Long x 88 inches Wide</b>	<b>138 CA</b>

Body Length	12 ft	14 ft	16 ft
<b>Recommended GVW</b>	19,000	26,000 - 33,000	26,000 - 33,000
<b>Hoist Capacity</b>	11.2 tons	15.2 tons	17.6 tons
<b>Cab-to-Axle inch length (CA)</b>	84 CA	120 CA	138 CA
<b>Outer Body Width</b>	88 inches	88 inches	88 inches
<b>Inner Body Height</b>	78 inches	84 inches	84 inches
<b>Body Details:</b>	10 gauge High Tensile floor with beveled side corners and front		
	3 inch channel cross bars on 15 inch centers		
	5 inch channel longs	7 inch channel longs	7 inch channel longs
	12 gauge front bulkhead with 3 corrugations and tube stiffeners 12 gauge sides and 2 corrugations and vertical posts		
	30 inch rear swing-out double doors with door latch	36 inch rear swing double doors with door latch	36 inch rear swing double doors with door latch
<b>Hoist:</b>	Scelzi CS615T-11 Electric over hydraulic Underbody Hoist, Class 40* <ul style="list-style-type: none"> <li>• 11.2 ton capacity with 18" overhang, full steel subframe</li> <li>• Double acting hoist with Power Up and Power Down PTO with direct mount pump</li> <li>• LED raised warning light</li> <li>• Inside Cab control</li> </ul>	Scelzi CS 6615 Direct Mount Underbody Hoist, Class 50* <ul style="list-style-type: none"> <li>• 15.2 ton capacity with 18" overhang</li> <li>• 2" hardwood cushion on truck chassis</li> <li>• Hydraulic tank</li> <li>• Double acting hoist with Power Up and Power Down PTO with direct mount pump</li> <li>• LED raised warning light</li> <li>• Inside Cab control</li> </ul>	Scelzi CS6620 Direct Mount Underbody Hoist, Class 50* <ul style="list-style-type: none"> <li>• 17.6 ton capacity with 23" overhang</li> <li>• 2" hardwood cushion on truck chassis</li> <li>• Hydraulic tank</li> <li>• Double acting hoist with Power Up and Power Down PTO with direct mount pump</li> <li>• LED raised warning light</li> <li>• Inside Cab control</li> </ul>

\*See page 33 for more hoist information



## Key Features and Options on Scelzi Water Trucks

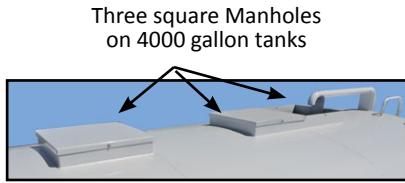
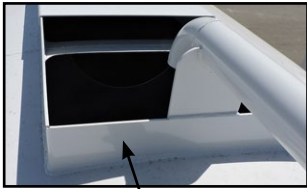

Three square Manholes on 4000 gallon tanks

Two 24" x 24" Manholes



3/16" thick steel tank skins welded inside and out

Driver and passenger-side Adjustable Spray Fittings

2.5" Hydrant Fill Pipe

Optional Hose Reel

Front and Rear Spray Bars

Heavy Duty Steel Ladder

24" Stinger Storage with lockable lid

Cab control box

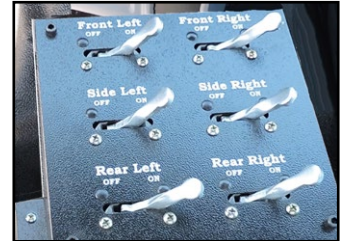

### Unique Scelzi Water Tank Features:

- A-Rubber Mounts between the long sill and chassis to minimize vibration
- B-Spring tank mounts to act as shock absorbers independent of the chassis



Optional LED Enhanced Light Kit



Optional 1/4" Thick Belly Steel Overlay

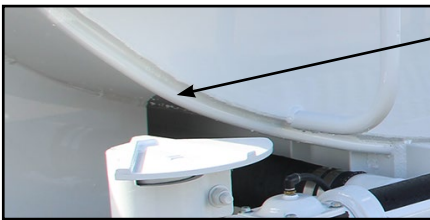





Photos may contain optional equipment - verify your specifications when you order.

## WT-2000      2,000 Gallons      Standard Specifications

### Standard

#### Features:

- Chelsea Air Shift PTO
- 4" x 3" Berkeley water pump (750 GPM)
- Spicer PTO Driveline
- 4" x 4" Water Manifold
- 3" Standard Air Valves
- 3" Slip on splash spray heads for front
- 3" x 53" Front spray bar with mounting brackets
- 3" Slip on splash spray heads for rear
- 3" x 53" Rear spray bar with mounting brackets
- 3" Adjustable driver side spray with VIC clamps
- 3" Adjustable passenger side spray with VIC clamps
- One control box inside cab with (6) air switches and Air control for PTO
- 1-1/2" Gate valve at manifold
- 3/4" Gate valve at manifold
- 4" Water tank mounts with 3/4" bolts
- One set of water tank fenders with hooks for hoses
- OEM Tail Stop & turn rear lights
- 2-1/2" Red marker lights seal beam
- 2-1/2" Amber marker lights seal beam
- 36" Rubber mud flaps
- 24" Stinger at rear with lockable lid
- 1/2" Sight gauge at rear

### Options:

- Hot shift PTO for Allison Transmission
- Upgrade to CLA – Val Air Valves
- 1/4" Thick overlay "Belly" at lower level of standard 3/16" thick tank, which significantly slows "rot-out" of bottom of tank
- 6" Diameter gravity water tank dump valve at rear bottom of tank with "Fan Nozzle".

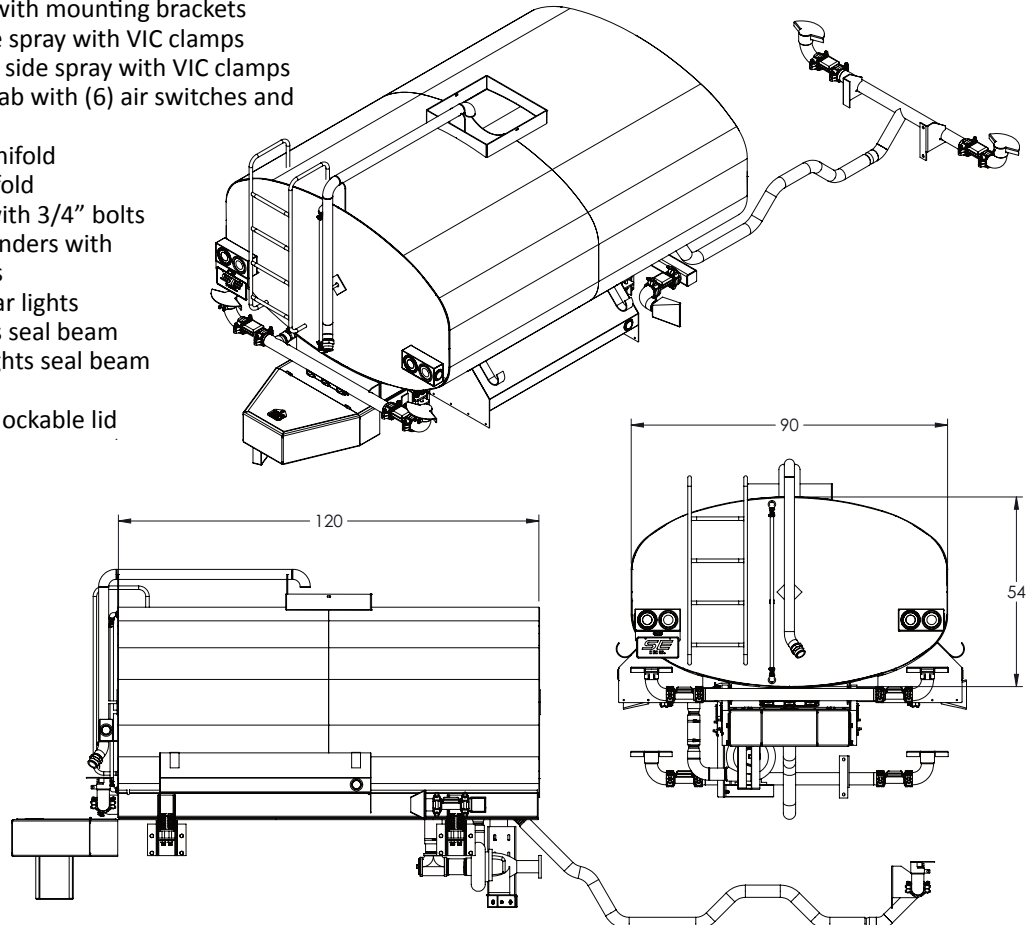



Photos may contain optional equipment - verify your specifications when you order.

## WT-2500

## 2500 Gallons

## Standard Specifications

### Standard Features:

- Chelsea Air Shift or Hot Shift PTO
- 4" x 3" Berkeley water pump (750 GPM)
- Spicer PTO Driveline
- 4" x 4" Water Manifold
- One set of water tank fenders with hooks for hoses
- 4" Water tank mounts with 3/4" bolts
- OEM tail stop & turn rear lights
- 3" Standard Air Valves
- 3" Slip on splash spray heads for front
- 3" x 53" Front spray bar with mounting brackets
- 3" Slip on splash spray heads for rear
- 3" x 53" Rear spray bar with mounting brackets
- 3" Adjustable driver side spray with VIC clamps
- 3" Adjustable passenger side spray with VIC clamps
- One control box inside cab with (6) air switches and Air control for PTO
- 1-1/2" Gate valve at manifold
- 3/4" Gate valve at manifold
- 2-1/2" Red marker lights seal beam
- 2-1/2" Amber market lights seal beam
- 36" Rubber mud flaps
- 24" Stinger at rear with lockable lid
- 1/2" Sight gauge at rear

### Options:

- Hot shift PTO for Allison Transmission
- Upgrade to CLA – Val Air Valves
- 1/4" Thick overlay "Belly" at lower level of standard 3/16" thick tank which significantly slows "rot-out" of bottom of tank
- 6" Diameter gravity water tank dump valve at rear bottom of tank with "Fan Nozzle".

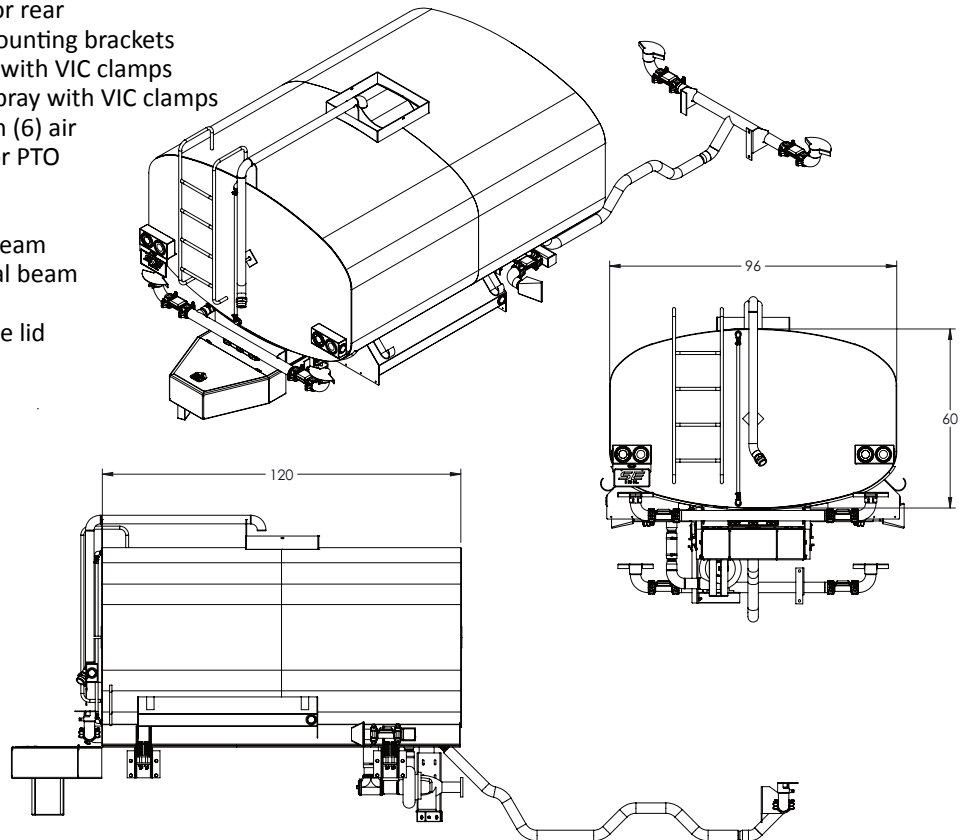



Photos may contain optional equipment - verify your specifications when you order.

## WT-4000      4000 Gallons      Standard Specifications

### Standard

- Features:**
- Chelsea Air Shift PTO for manual transmission
  - 4" x 3" Berkeley water pump, (750 GPM)
  - Spicer PTO Driveline
  - 4" x 4" Water Manifold
  - 3" Standard Air Valves
  - 3" Slip on splash spray heads for front
  - 3" x 53" Front spray bar with mounting brackets
  - 3" Slip on splash spray heads for rear
  - 3" x 53" Rear spray bar with mounting brackets
  - 3" Adjustable S/S spray with VIC clamps
  - 3" Adjustable C/S spray with VIC clamps
  - One control box inside cab with (6) air switches and Air control for PTO
  - OEM tail stop and turn rear lights
  - 2-1/2" Red marker lights seal beam
  - 2-1/2" Amber marker lights seal beam
  - 36" Rubber mud flaps
  - 24" Stinger at rear with lockable lid
  - 1/2" Sight gauge at rear
  - 1-1/2" Gate valve at manifold
  - 3/4" Gate valve at manifold
  - 4" Water tank mounts with 3/4" bolts
  - One set of water tank fenders with hooks for hoses

### Options:

- Hot shift PTO for Allison Transmission
- Upgrade to CLA – Val Air Valves
- 1/4" Thick overlay "Belly" at lower level of standard 3/16" thick tank, which significantly slows "rot-out" of bottom of tank
- 6" Diameter gravity water tank dump valve at rear bottom of tank with "Fan Nozzle".

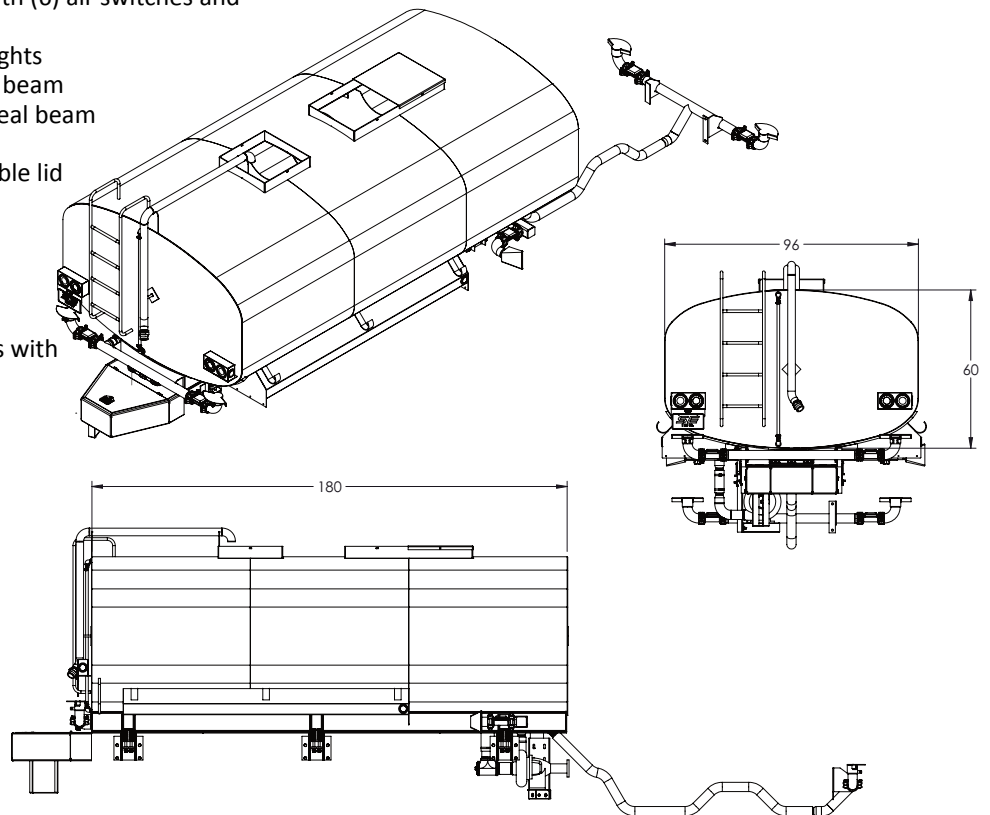



**SCELZI Enterprises EQUIPMENT**

# WHOLESALE TRUCK PARTS OUTLET

2645 South Cherry Street • Fresno • CA • 93706

**Call Toll-Free 1-800-858-2883**

Local (559) 237-5541



Parts Manager  
Richard Contreras

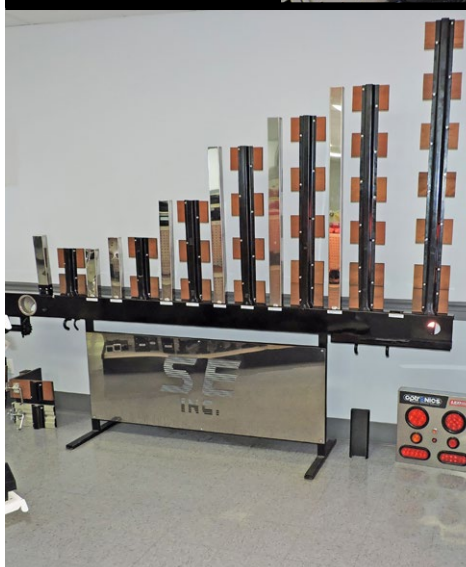

*A Huge Selection  
of Parts, including  
Cranes, Hoists,  
Locks, Toolboxes,  
and more*

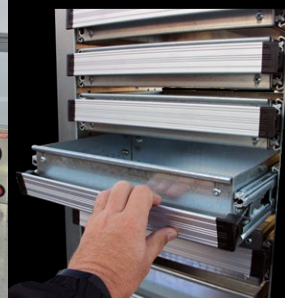

*The Highest Quality parts for your Scelzi or non-Scelzi truck body at great prices. Buy from the Body Parts Experts!*



# Parts and Optional Equipment

## For ALL Bodies

Backpacks .....	page 47
Beacon Plate/Pedestal .....	page 48
Cranes .....	page 51
Hitches .....	page 48
Ladder Racks .....	page 51
Lift Gates .....	page 51
Locking Systems .....	page 50
Polyurea Lining .....	page 47
Spare Tire Carrier .....	page 48
Tool Boxes /Drawers .....	page 46
Vise Stands .....	page 49
Water Cask Holders .....	page 48

## For SERVICE Bodies

Roller Tops .....	page 52
Trailer Plugs .....	page 52

## Tool Boxes

Tooboxes are available in Black or White as standard

### Closed Top

Scelzi Top Mount, Closed Top model

LONG	HIGH	DEEP
72"	18"	18"
96"	18"	18"
108"	18"	18"



### Open Top

Scelzi Top Mount, Open Top model

LONG	HIGH	DEEP
48"	18"	18"
72"	18"	18"
96"	18"	18"
108"	18"	18"



### Underbody

LONG	HIGH	DEEP
24"	18"	18"
30"	18"	18"
36"	18"	18"
40"	18"	18"
48"	18"	18"
60"	18"	18"



Open Top Black  
Toolbox With Optional  
Dividers



Modular Tool Drawer Systems

NEW Design for 2019

- Just Press Down to pull out - the Best gets even BETTER
- Available in 3" through 8" High Heavy Duty Drawers
- 250# Test
- Galvanized Steel only
- Drawer Dividers sold separately



Back Packs

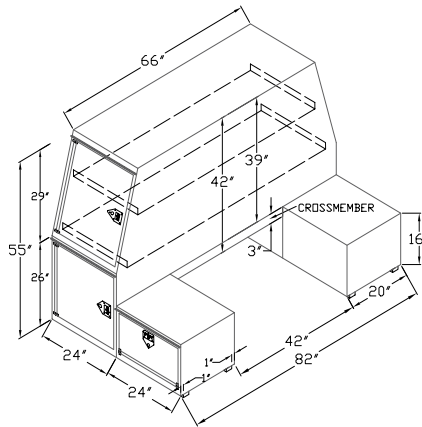
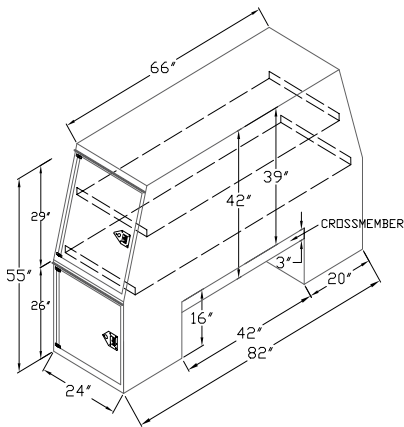

Scelzi Tool Box Roller Trays

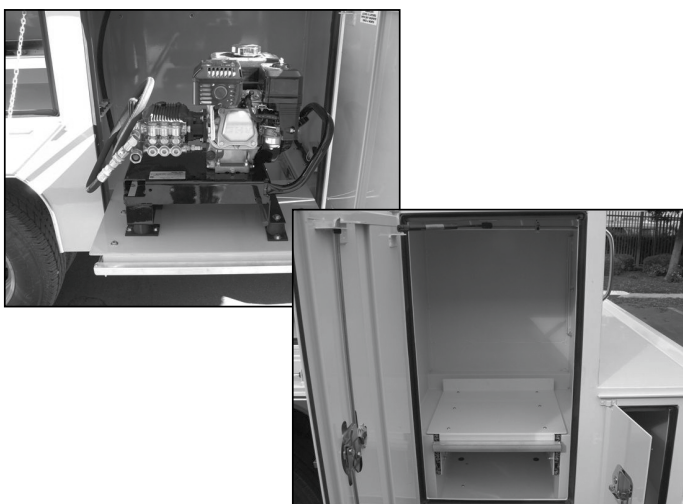

Polyurea Lining

Non-slip surfacing for beds and bumpers

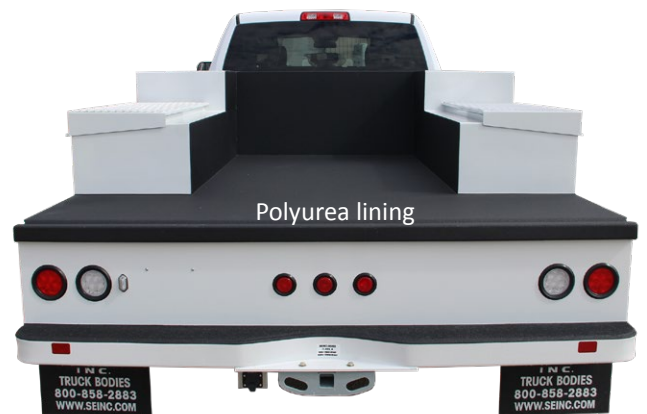

## Water Cask Holders

Standard Water Cask Holder With Strap  
PART NO SE190015

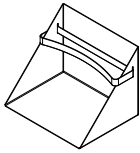

Ring Style Water Cask Holder  
PART NO SE190014

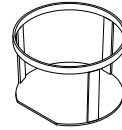

## Spare Tire Carriers

**PART #SE143000**

**UNDERBODY SPARE TIRE CARRIER**

-FORD F-350-550 DRW,  
DODGE 3500-5500 DRW  
-CAN BE USED ON FREIGHTLINER  
AND INTERNATIONAL  
LOW PROFILE MODELS  
(MAXIMUM TIRE DIAMETER 34")

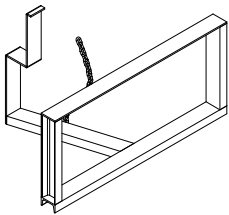

NOTE: MUST BE LOCATED ON DRIVER SIDE  
WILL NOT WORK WITH MIDSHIP  
OR DUAL TANK CONFIGURATIONS

**PART #SE143001**

**UNDERBODY SPARE TIRE CARRIER**

FOR CLASS 5-7 CONVENTIONAL CAB  
(IE FREIGHTLINER M2) (11R 22.5 TIRES)  
(MAXIMUM TIRE DIAMETER 42 1/2")

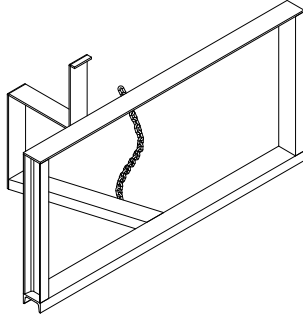

NOTE: NOT FOR USE ON VEHICLES WITH 12R22.5 TIRES  
TIRE SIZE MUST BE NOTED ON WORK ORDER

**UNDERBODY SPARE TIRE CARRIER -  
DRIVER SIDE APPLICATION SHOWN**

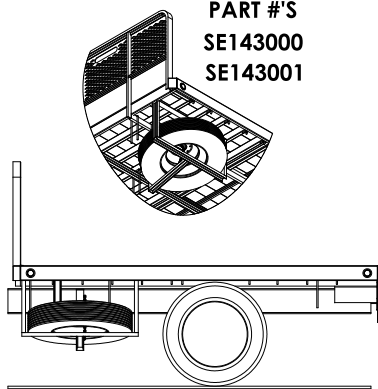

**PART #'S  
SE143000  
SE143001**

**VERTICAL SPARE TIRE HOLDER**

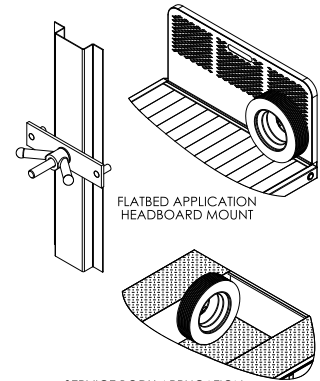

FLATBED APPLICATION  
HEADBOARD MOUNT

SERVICE BODY APPLICATION  
BACKWRAPPER MOUNT

## Beacon Plates and Pedestals

**SE091020**

BEACON PLATE, 9" X 9"

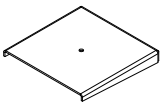

**SE091021**

BEACON PLATE, 7" X 7"

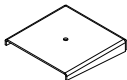

**SE091022**

MINI LIGHTBAR PLATE, 9" X 18"

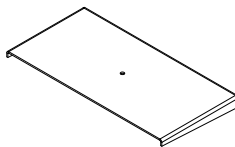

**SE192034**

BEACON PEDESTAL, 7" X 7"  
PLATE, FOR 38" TALL BODY

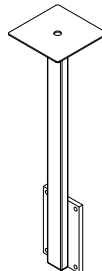

BODY HEIGHT	PART NUMBER
33" TALL BODY	SE192033
38" TALL BODY	SE192034
43" TALL BODY	SE192035
60" TALL BODY	SE192037

**SE192031**

BEACON PEDESTAL, 9" X 9"  
PLATE, FOR 38" TALL BODY

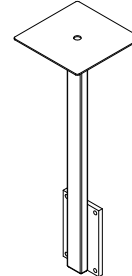

BODY HEIGHT	PART NUMBER
33" TALL BODY	SE192030
38" TALL BODY	SE192031
43" TALL BODY	SE192032
60" TALL BODY	SE192036

## Hitches

**Receiver Hitches**

CLASS 4 - 10,000#  
Capacity, 1000#  
Tongue Weight

CLASS 5 - 18,000#  
Capacity, 1,800#  
Tongue Weight

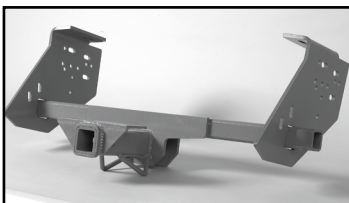

**Dump Hitches**

CLASS 4 - 10,000#  
Capacity, 1000#  
Tongue Weight

CLASS 5 - 18,000#  
Capacity, 1,800#  
Tongue Weight





## Vise Stands

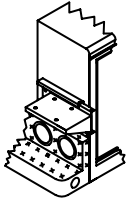

Bolt On Stainless Steel Panel

SSV-128

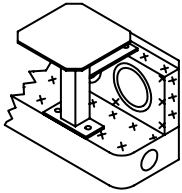

Standard Vise Stand Non-Removeable 9" x 9" Plate

SVS-121



--

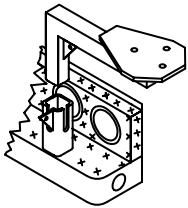

Lockable Vise Stand With Removeable Plates  
 •Small BC210 or  
 •Large BC410 (PG & E style)

LVSR-210  
 LVSR-410

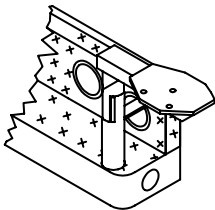

Swivel Base Vise Stand With Removeable Plates  
 •Small BC210 or  
 •Large BC410

SWV-127

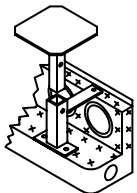

Vise Stand with Removeable 9" x 9" Plate

VSR-123

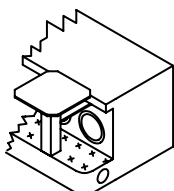

Weld Vise Stand On Work Deck or Bumper Non-powder coated

VSW-122



## PIPE HOLDERS

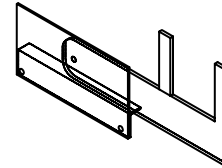

Pipe Holder Between Cab and Body

PH-124

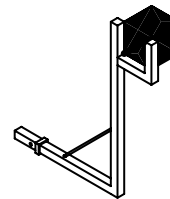

Front Bumper Pipe Holder WITH Bucket

BPH-126

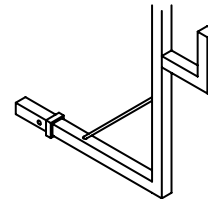

Front Bumper Pipe Holder Without Bucket

BPH-125



## Electronic Locking Systems

### Scelzi Electronic Locking System®

Covered under patent #8,869,576 B2

Rotary electronic master lock system provides additional protection for service body compartments in addition to the Scelzi locking T-handles. The Scelzi Electronic Locking System® can be used with an auxiliary remote or can be tied in to the factory electronic door locking system if the chassis is equipped with the automatic door lock option. The system utilizes an electronic actuator to activate a rotating rod to positively lock a cam system to the door. This provides a remote system to enhance the body security without the addition of parts protruding to the outside of the body.

The system is available on all standard service bodies -- contact your factory representative for availability on other body styles.

For both Electronic and Manual systems, a rotating rod is activated to lock a cam system to the door.



Can be programmed into the truck's cab security key for ease of use.

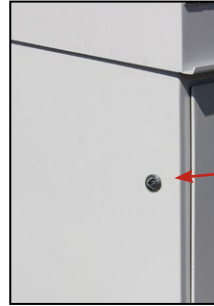

Electronic actuator. When activated the patented locking system rotates the rod and cam system

Heavy duty cam and hook

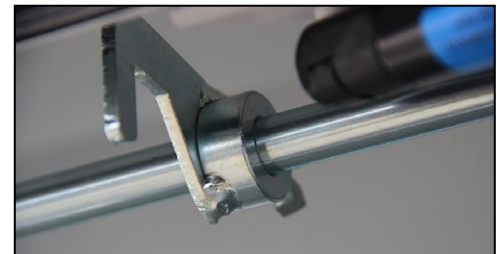

### Scelzi Manual Master Lock System\*

Manual master lock system provides an independent locking system to increase vehicle security above the level offered by traditional compartment locks. The system utilizes a positive lock cam system controlled by a stainless steel handle located on the rear of each service body side pack. The handle is then secured in the locked position with a padlock. All hardware provided is stainless steel or zinc coated for enhanced corrosion protection.

The system is available on all standard service bodies, for applications relating to custom and crane bodies contact your factory representative.

Unlocked

Locked



When manually activated the locking system rotates the rod and cam system that hooks into the door

\* Proprietary Scelzi Design

## Ladder Racks

Standard Ladder Rack



Forklift Ladder Rack

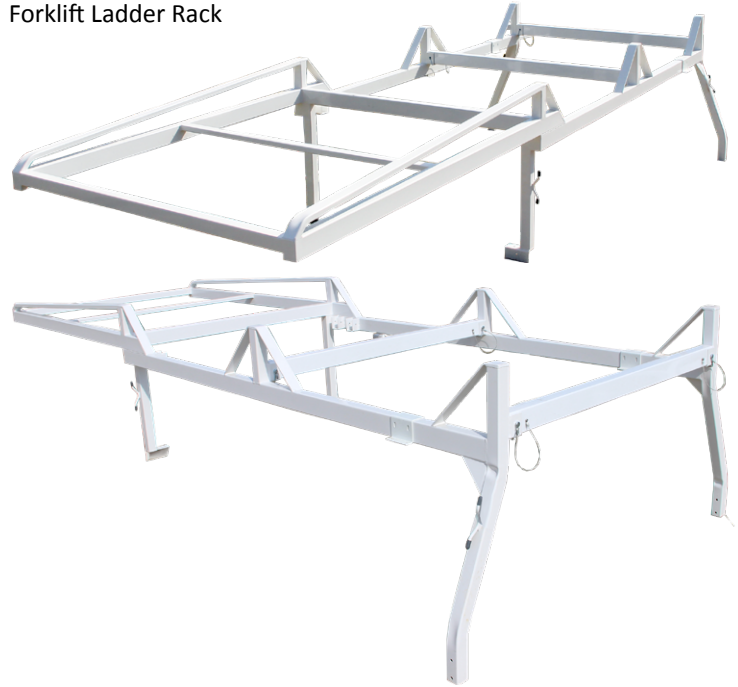

## Cranes and Lift Gates



## Miscellaneous Holders and Accessories



Cone Holders



Tamper Holder

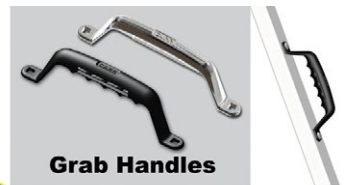

Grab Handles

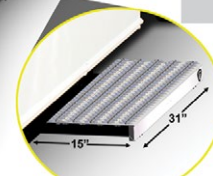

Steps and Handles

## Roller Tops

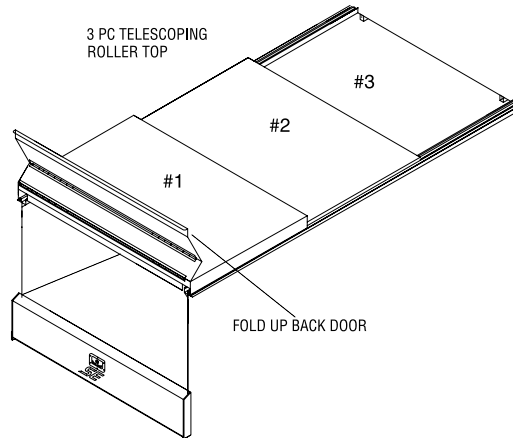
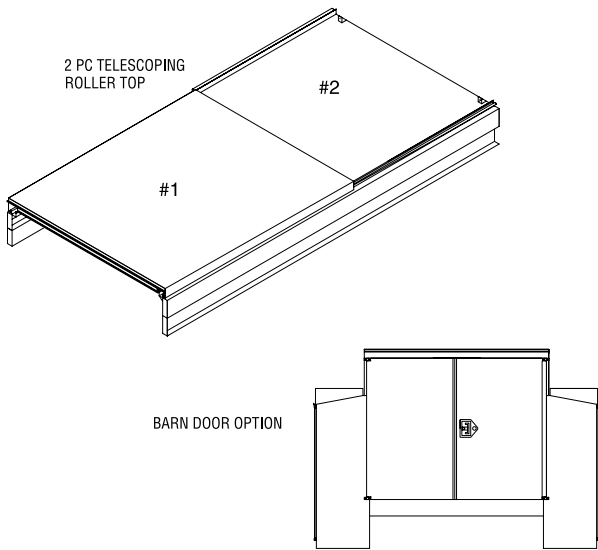

Roller Tops come with stainless steel track and rollers.

**2-PIECE ROLLER TOP**  
Available for bodies of 80", 98" or 108" long

**3-PIECE ROLLER TOP**  
Available for bodies of 98", 108", 132" or 156" long

Comes standard with fold up back door that includes overlapping tailgate for locking. Can be raised from 3" up to 14" tall and can be ordered with barn doors.



## Trailer Plugs

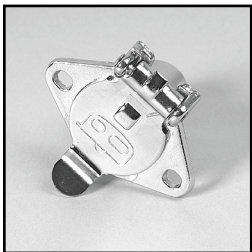

No. 11-410  
4 Pin - Cole Hersey  
Chrome



No. 12063  
7 Pin - Round Plug

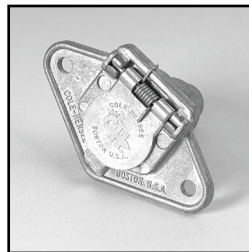

No. 1235  
6 Pin - Cole Hersey  
Plug



No. 12707  
7 Pin - Flat RV Plug



# Scelzi Classics

*These truck bodies are still available with Extended Lead Times*

**13 ft A-Frame (108 CA)**



**15 ft A-Frame (120 CA)**



A 13 ft or 15 ft long A-Frame body with crane. Diamond plate 3/16" steel, cab high headboard, tubing for side racks, custom tail plate with two vise racks, diamond plate steel covering winch, kill switch, back up alarm, pintle hitch, multiple tool boxes.

## Contour Service Bodies



Premium Quality Service Bodies with unique contoured edges and corners. Contour ladder rack, conduit boxes open on top, standard vise stand and receiver hitch. The top-of-the-line Service Body.

Model	Length	CA	Compartment Height	Rear Wheel
CSB-98	98 inches	56	38 "	Single
CSB-108	108 inches	60	38"	Dual



**CRUISER Body**

**11 ft long**

**(108 CA)**



Stylish 11 foot long (132 inches) Cruiser Body with hand rail and 5th wheel hitch under removeable steel cover in aluminum bed.

# Scelzi Classics Still Available For Quote - Contact Us

Articulating Telescoping Aerial Device (bucket lift)

UTLI46A Specifications



Pictured above is ATA Device on Scelzi 8 x 14 flatbed, WO #108160. Body has PTO and pump for boom lift, back up alarm, basket capacity of 400 lbs, and 540 degree boom rotation with mechanical stop. Meets or exceeds ANSI A92.2-2001 and OSHA requirements

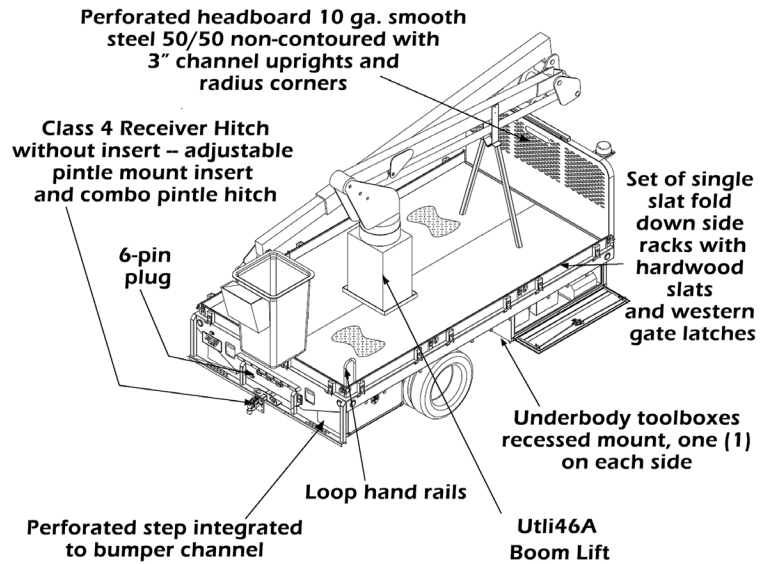

## CRANE BODIES (non-Western)

See page 31 for Western Crane Bodies



Premium Quality Crane bodies engineered for cranes with 5,000 lb lifting capacity and higher.

Model	Length	CA	Body Width
CB-132	132 inches	84	94 or 96"
CB-156	156 inches	108	96"
CB-166	166 inches	120	96"



Special Underbody Construction

- 3/16" Thick Head Board
- 14 Gauge Steel Shell
- 11 Gauge Diamond Plate Steel Overlay Includes: Bed, Floor, Sides and Top of Compartments

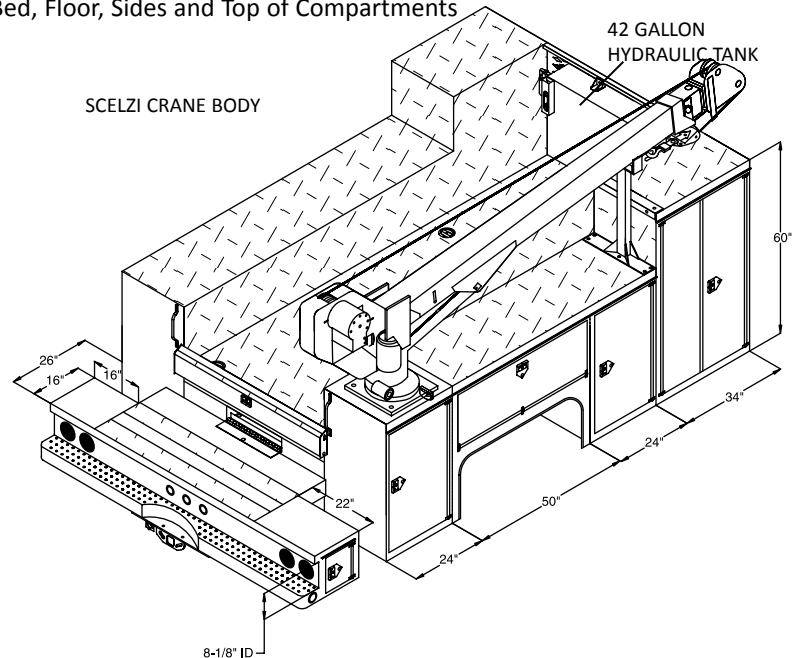



# Custom Bodies



Custom WO120437



8 x 10 ft Custom Flatbed  
WO147019



Custom WO24926



Cone Holder Truck WO150641

## Custom Roadside Flatbed with Impact Attenuator

- Body Dimensions: 8 ft Wide x 16 ft Long  
120 CA
- Color: Custom
- Side Racks: 10" tall side racks with stainless steel stakes, hardwood slats, and western gate latches
- Flooring: 3/16" diamond plate floor



*Photos here are examples only and do not include the full range of custom body options available for quote*

**Please Note: Custom Bodies Require Extended Lead Times**



# SCELZI Enterprises Incorporated

Custom Truck Body Manufacturing

*Building An American Legacy One Truck Body At A Time*



The Scelzi Enterprises Fleet



[www.seinc.com](http://www.seinc.com)



## Pool Locations

### Fresno

Scelzi Enterprises, Inc.  
Corporate Headquarters  
2286 East Date Avenue  
Fresno, CA. 93706  
Office: (559) 237-5541  
Toll Free: (800) 858-2883  
Fax: (559) 237-5554

### Denver

Scelzi Enterprises, Inc.  
203 5th Avenue  
La Salle, CO 80645  
Office: (559) 237-5541  
Toll Free: (800) 858-2883  
Fax: (559) 496-3202

### Riverside

Scelzi Enterprises, Inc.  
2693 Rubidoux Blvd.  
Riverside, CA 92509  
Office: (559) 237-5541  
Toll Free: (800) 858-2883  
Fax: (559) 496-3202

### Oregon

PMI Truck Bodies, Inc.  
255 Queen Avenue, SE  
Albany, OR 97322-3305  
Toll Free: (888) 747-3357

### Washington

PMI Truck Bodies, Inc.  
2219 112th Street East  
Tacoma, WA 98445  
Office: (253) 539-3339  
Fax: (253) 539-3335