

Henderson

MDM[™]SERIES



CLASS 4 & 5 MEDIUM-DUTY MUNICIPAL TRUCK EQUIPMENT

The Dependable Ones

Henderson

MDM

FIRST

RESPONDER™

Class 4 Snow-Fighting Package



MDM™ TAILGATE SPREADERS

TGS undertailgate spreader: 12" or 16" side heights, 201 stainless steel hopper and 6" electric auger. Cover provides full dump body use without removing the spreader.

RTS replacement tailgate spreader: 12" or 16" side heights, 201 stainless steel hopper and 6" electric auger.



Henderson

Packages Available	For these OEM Chassis
■ Dump Body Only	■ Ford: F-450 & F-550
■ Dump Body & Spreader	■ Dodge/Ram: 4500 & 5500
■ Dump Body & Plow	■ Chevy/GMC: 4500 & 5500
■ Dump Body, Plow & Spreader	■ Navistar CV (Class 4/5)



MDM™ DUMP BODIES

Design your dump body with either fixed or fold-down sides and 12" or 16" side heights. Bodies are available in 9' or 11' lengths in mild steel or 201 stainless steel construction. Flooring choices include 7- or 10-gauge Grade 50 steel on mild steel bodies, and 10-gauge stainless steel or 3/16" AR450F on 201 stainless steel bodies. 4 cab shield options and a double-wall tailgate complete the body.



MDM™ HERO SNOW PLOWS

- 9' painted straight blade with Full-Trip or Trip-Edge
- 10' painted straight blade with Trip-Edge
- 10' Heavy-duty painted straight blade with full-trip
- 9.5' or 10.5' stainless steel V-plow with trip-edges

MDM™ DUMP BODIES & SPREADERS

Powder-coated painted steel bodies or stainless steel bodies available

10- or 7-Gauge Grade 50 floor on painted steel bodies

10-gauge stainless steel or 3/16" AR450F floor on stainless steel bodies

12" or 16" side heights and 9' or 11' body lengths

Tailgates can pivot from top or bottom hinges



Sealed solid-state electronics for reliability

Pin-on tailgate spreader with 6" electric auger. Integral cover allows dumping while spreader is installed.





Bolt-on cab shields (quarter and half) in standard, medium and tall heights - each with hidden bolt design. Hidden hardware & window included on all versions.

Fixed or available fold-down sides with 180° range of motion and concealed hinges



Formed trapezoidal longills and cross-memberless understructure eliminate trapped corrosion

Scissors hoist with no welded joints to the vehicle frame

12V electric-over-hydraulic pump pack



Standard tailgate-coal chute tailgate available

Pintle plate with D-rings

Pivoting spinner always remains near parallel to the road for perfect material spreading



Power Plus™ power distribution panel mounted inside cab back wall provides fused links to all MDM First Responder equipment, with a master breaker to protect the chassis electrical system

Integrated controls for dump body and spinner

MOM™ HERO™ SNOW PLOWS

Henderson

Henderson

Rubber deflectors

Curb guards

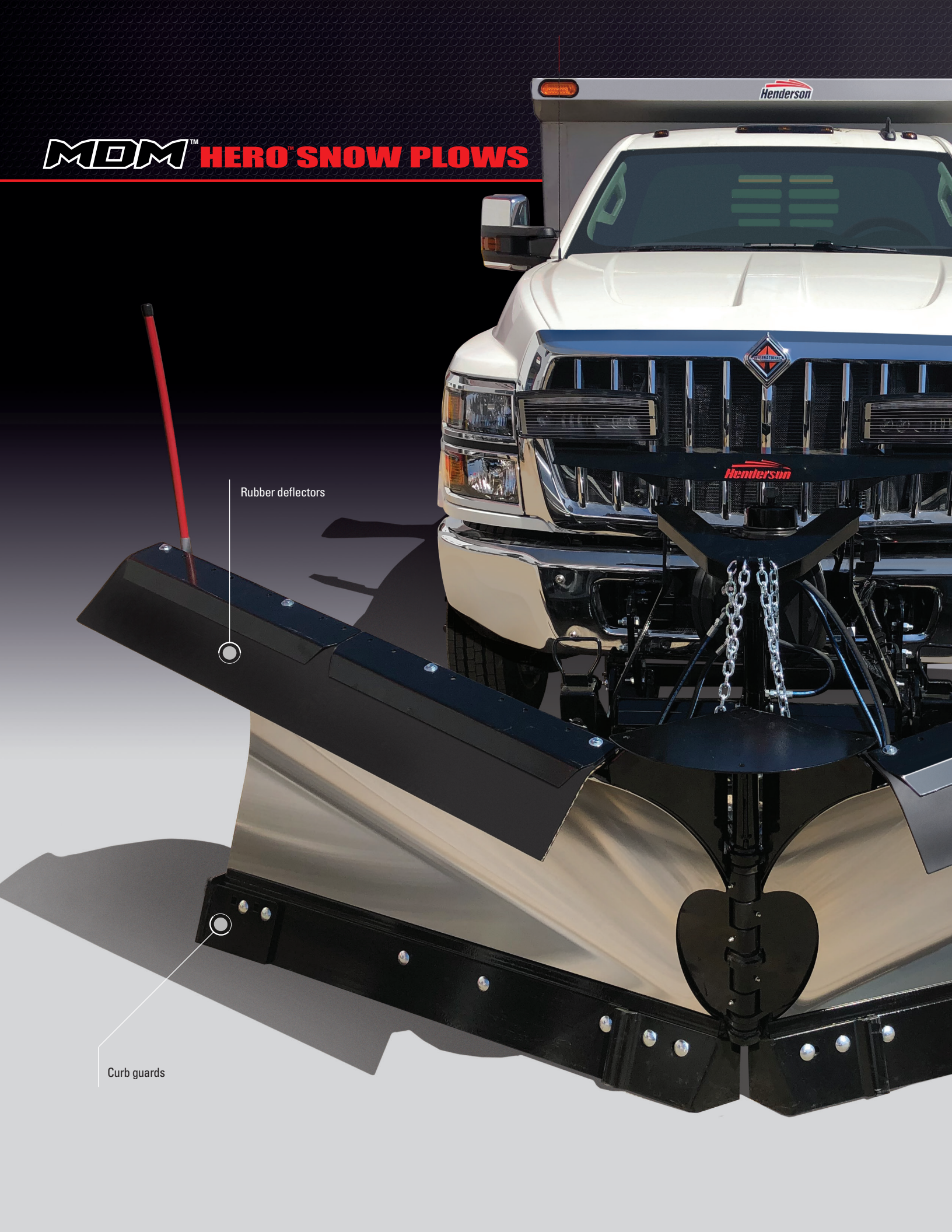



Halogen or LED Lights



Steel or Carbide cutting edges



- 9' painted straight blade with Full-Trip or Trip-Edge
- 10' painted straight blade with Trip-Edge

- 10' Heavy-duty painted straight blade with full-trip

- 9.5' or 10.5' stainless steel V-plow with trip-edges

FIXED SIDES DUMP BODY DIMENSIONS & CAPACITY CHART (BODY ONLY)

BODY MATERIAL	FLOOR MATERIAL	LENGTH	SIDE HEIGHT	INSIDE WIDTH	INSIDE LENGTH	OUTSIDE WIDTH	OUTSIDE LENGTH	BODY WEIGHT (lbs)	CAPACITY (cu. yd.)	HOIST TYPE	CYLINDER SIZE	HOIST CAPACITY (with 6" overhang)	HOIST CLASS (NTEA)
MILD	10-GA. GR50	9'	12"	85.7"	111"	95.7"	114.8"	1256	2.5	UNDERBODY SCISSOR-DOUBLE ACTING	5.5" x 16" x 2" ROD	11 TONS	40
MILD	7-GA. GR50	9'	12"	85.7"	111"	95.7"	114.8"	1361	2.5	UNDERBODY SCISSOR-DOUBLE ACTING	5.5" x 16" x 2" ROD	11 TONS	40
MILD	10-GA. GR50	9'	16"	85.7"	111"	95.7"	114.8"	1305	3.2	UNDERBODY SCISSOR-DOUBLE ACTING	5.5" x 16" x 2" ROD	11 TONS	40
MILD	7-GA. GR50	9'	16"	85.7"	111"	95.7"	114.8"	1410	3.2	UNDERBODY SCISSOR-DOUBLE ACTING	5.5" x 16" x 2" ROD	11 TONS	40
MILD	10-GA. GR50	11'	12"	85.7"	135"	95.7"	138.8"	1478	3.0	UNDERBODY SCISSOR-DOUBLE ACTING	5.5" x 16" x 2" ROD	9 TONS	40
MILD	7-GA. GR50	11'	12"	85.7"	135"	95.7"	138.8"	1602	3.0	UNDERBODY SCISSOR-DOUBLE ACTING	5.5" x 16" x 2" ROD	9 TONS	40
MILD	10-GA. GR50	11'	16"	85.7"	135"	95.7"	138.8"	1542	4.0	UNDERBODY SCISSOR-DOUBLE ACTING	5.5" x 16" x 2" ROD	9 TONS	40
MILD	7-GA. GR50	11'	16"	85.7"	135"	95.7"	138.8"	1666	4.0	UNDERBODY SCISSOR-DOUBLE ACTING	5.5" x 16" x 2" ROD	9 TONS	40
201 SS	10-GA. SS	9'	12"	85.7"	111"	95.7"	114.8"	1256	2.5	UNDERBODY SCISSOR-DOUBLE ACTING	5.5" x 16" x 2" ROD	11 TONS	40
201 SS	3/16" AR400F	9'	12"	85.7"	111"	95.7"	114.8"	1361	2.5	UNDERBODY SCISSOR-DOUBLE ACTING	5.5" x 16" x 2" ROD	11 TONS	40
201 SS	10-GA. SS	9'	16"	85.7"	111"	95.7"	114.8"	1305	3.2	UNDERBODY SCISSOR-DOUBLE ACTING	5.5" x 16" x 2" ROD	11 TONS	40
201 SS	3/16" AR400F	9'	16"	85.7"	111"	95.7"	114.8"	1410	3.2	UNDERBODY SCISSOR-DOUBLE ACTING	5.5" x 16" x 2" ROD	11 TONS	40
201 SS	10-GA. SS	11'	12"	85.7"	135"	95.7"	138.8"	1478	3.0	UNDERBODY SCISSOR-DOUBLE ACTING	5.5" x 16" x 2" ROD	9 TONS	40
201 SS	3/16" AR400F	11'	12"	85.7"	135"	95.7"	138.8"	1602	3.0	UNDERBODY SCISSOR-DOUBLE ACTING	5.5" x 16" x 2" ROD	9 TONS	40
201 SS	10-GA. SS	11'	16"	85.7"	135"	95.7"	138.8"	1542	4.0	UNDERBODY SCISSOR-DOUBLE ACTING	5.5" x 16" x 2" ROD	9 TONS	40
201 SS	3/16" AR400F	11'	16"	85.7"	135"	95.7"	138.8"	1666	4.0	UNDERBODY SCISSOR-DOUBLE ACTING	5.5" x 16" x 2" ROD	9 TONS	40

FOLD-DOWN SIDES DUMP BODY DIMENSIONS & CAPACITY CHART (BODY ONLY)

BODY MATERIAL	FLOOR MATERIAL	LENGTH	SIDE HEIGHT	INSIDE WIDTH	INSIDE LENGTH	OUTSIDE WIDTH	OUTSIDE LENGTH	BODY WEIGHT (lbs)	CAPACITY (cu. yd.)	HOIST TYPE	CYLINDER SIZE	HOIST CAPACITY (with 6" overhang)	HOIST CLASS (NTEA)
MILD	10-GA. GR50	9'	12"	85.7"	111"	95.7"	114.8"	1226	2.5	UNDERBODY SCISSOR-DOUBLE ACTING	5.5" x 16" x 2" ROD	11 TONS	40
MILD	7-GA. GR50	9'	12"	85.7"	111"	95.7"	114.8"	1331	2.5	UNDERBODY SCISSOR-DOUBLE ACTING	5.5" x 16" x 2" ROD	11 TONS	40
MILD	10-GA. GR50	9'	16"	85.7"	111"	95.7"	114.8"	1256	3.2	UNDERBODY SCISSOR-DOUBLE ACTING	5.5" x 16" x 2" ROD	11 TONS	40
MILD	7-GA. GR50	9'	16"	85.7"	111"	95.7"	114.8"	1361	3.2	UNDERBODY SCISSOR-DOUBLE ACTING	5.5" x 16" x 2" ROD	11 TONS	40
MILD	10-GA. GR50	11'	12"	85.7"	135"	95.7"	138.8"	1433	3.0	UNDERBODY SCISSOR-DOUBLE ACTING	5.5" x 16" x 2" ROD	9 TONS	40
MILD	7-GA. GR50	11'	12"	85.7"	135"	95.7"	138.8"	1538	3.0	UNDERBODY SCISSOR-DOUBLE ACTING	5.5" x 16" x 2" ROD	9 TONS	40
MILD	10-GA. GR50	11'	16"	85.7"	135"	95.7"	138.8"	1470	4.0	UNDERBODY SCISSOR-DOUBLE ACTING	5.5" x 16" x 2" ROD	9 TONS	40
MILD	7-GA. GR50	11'	16"	85.7"	135"	95.7"	138.8"	1575	4.0	UNDERBODY SCISSOR-DOUBLE ACTING	5.5" x 16" x 2" ROD	9 TONS	40
201 SS	10-GA. SS	9'	12"	85.7"	111"	95.7"	114.8"	1256	2.5	UNDERBODY SCISSOR-DOUBLE ACTING	5.5" x 16" x 2" ROD	11 TONS	40
201 SS	3/16" AR400F	9'	12"	85.7"	111"	95.7"	114.8"	1380	2.5	UNDERBODY SCISSOR-DOUBLE ACTING	5.5" x 16" x 2" ROD	11 TONS	40
201 SS	10-GA. SS	9'	16"	85.7"	111"	95.7"	114.8"	1305	3.2	UNDERBODY SCISSOR-DOUBLE ACTING	5.5" x 16" x 2" ROD	11 TONS	40
201 SS	3/16" AR400F	9'	16"	85.7"	111"	95.7"	114.8"	1429	3.2	UNDERBODY SCISSOR-DOUBLE ACTING	5.5" x 16" x 2" ROD	11 TONS	40
201 SS	10-GA. SS	11'	12"	85.7"	135"	95.7"	138.8"	1478	3.0	UNDERBODY SCISSOR-DOUBLE ACTING	5.5" x 16" x 2" ROD	9 TONS	40
201 SS	3/16" AR400F	11'	12"	85.7"	135"	95.7"	138.8"	1602	3.0	UNDERBODY SCISSOR-DOUBLE ACTING	5.5" x 16" x 2" ROD	9 TONS	40
201 SS	10-GA. SS	11'	16"	85.7"	135"	95.7"	138.8"	1542	4.0	UNDERBODY SCISSOR-DOUBLE ACTING	5.5" x 16" x 2" ROD	9 TONS	40
201 SS	3/16" AR400F	11'	16"	85.7"	135"	95.7"	138.8"	1666	4.0	UNDERBODY SCISSOR-DOUBLE ACTING	5.5" x 16" x 2" ROD	9 TONS	40

TAILGATE OPTIONS

MATERIAL	SIZE	STYLE	INTENDED USE
MILD	18"	STANDARD / PLAIN	FOR 12" SIDE HEIGHT BODIES
MILD	22"	STANDARD / PLAIN	FOR 16" SIDE HEIGHT BODIES
201SS	18"	STANDARD / PLAIN	FOR 12" SIDE HEIGHT BODIES
201 SS	22"	STANDARD / PLAIN	FOR 16" SIDE HEIGHT BODIES
MILD	18"	TAILGATE WITH 1 CENTER COAL CHUTE	FOR 12" SIDE HEIGHT BODIES
MILD	22"	TAILGATE WITH 1 CENTER COAL CHUTE	FOR 16" SIDE HEIGHT BODIES
201 SS	18"	TAILGATE WITH 1 CENTER COAL CHUTE	FOR 12" SIDE HEIGHT BODIES
201 SS	22"	TAILGATE WITH 1 CENTER COAL CHUTE	FOR 16" SIDE HEIGHT BODIES

CAB SHIELD OPTIONS

MATERIAL	SIZE	HEIGHT	LIGHTS
MILD	QUARTER	STANDARD	NONE
MILD	QUARTER	STANDARD	2 FORWARD / 2 REARWARD / 1 EACH SIDE
MILD	QUARTER	MEDIUM	NONE
MILD	QUARTER	MEDIUM	2 FORWARD / 2 REARWARD / 1 EACH SIDE
MILD	QUARTER	TALL	NONE
MILD	QUARTER	TALL	2 FORWARD / 2 REARWARD / 1 EACH SIDE
MILD	HALF	STANDARD	NONE
MILD	HALF	STANDARD	2 FORWARD / 2 REARWARD / 1 EACH SIDE
201 SS	QUARTER	STANDARD	NONE
201 SS	QUARTER	STANDARD	2 FORWARD / 2 REARWARD / 1 EACH SIDE
201 SS	QUARTER	MEDIUM	NONE
201 SS	QUARTER	MEDIUM	2 FORWARD / 2 REARWARD / 1 EACH SIDE
201 SS	QUARTER	TALL	NONE
201 SS	QUARTER	TALL	2 FORWARD / 2 REARWARD / 1 EACH SIDE
201 SS	HALF	STANDARD	NONE
201 SS	HALF	STANDARD	2 FORWARD / 2 REARWARD / 1 EACH SIDE

SPREADER OPTIONS

MATERIAL	STYLE	INTENDED USE
201 SS	TGS - STD TAILGATE SYSTEM	FOR 12" SIDE HEIGHT BODIES
201 SS	TGS - STD TAILGATE SYSTEM	FOR 16" SIDE HEIGHT BODIES
201SS	RTS - REPLACEMENT TAILGATE SYSTEM	FOR 12" SIDE HEIGHT BODIES
201 SS	RTS - REPLACEMENT TAILGATE SYSTEM	FOR 16" SIDE HEIGHT BODIES

PLOW BLADE ASSEMBLY OPTIONS

MATERIAL	SIZE	STYLE	TRIP STYLE	FINISH
201 SS	9.5'	V-PLOW	TRIP EDGE	F: NATURAL / R: BLACK PAINTED
201 SS	10.5'	V-PLOW	TRIP EDGE	F: NATURAL / R: BLACK PAINTED
MILD	9'	STRAIGHT	FULL TRIP	F&R: BLACK PAINTED
MILD	10'	STRAIGHT - HEAVY-DUTY	FULL TRIP	F&R: BLACK PAINTED
MILD	9'	STRAIGHT	TRIP EDGE	F&R: BLACK PAINTED
MILD	10'	STRAIGHT	TRIP EDGE	F&R: BLACK PAINTED



1085 S. Third Street, Manchester, IA 52057
 Toll Free: (800) 359-4970
www.HendersonProducts.com

Sourcewell CONTRACT: 080818-HPI



HP-060 01/22